

YOSEMITE NATIONAL PARK UTILITIES BRANCH

SEWER SYSTEM MANAGEMENT PLAN EL PORTAL SANITARY SEWER SYSTEM (CS 5SSO10735)



EL PORTAL SEWER SYSTEM MANAGEMENT PLAN

FINAL

June 1, 2013

YOSEMITE NATIONAL PARK UTILITIES BRANCH

SEWER SYSTEM MANAGEMENT PLAN EL PORTAL SANITARY SEWER SYSTEM (CS 5SSO10735)

SEWER SYSTEM MANAGEMENT PLANS for YOSEMITE NATIONAL PARK

Prepared for:
Yosemite National Park, California

Contract No. C8078080174,

Task Order No. P11PD81776

Prepared by:

David B. Brooke June 01, 2013

David B. Brooke, P.E.
Project Engineer,
Holladay Engineering Co.

Date



Approved:

Under the National Park Service's direction and supervision in accordance with its policies and procedures.

Paul Laymon

Paul Laymon, Utilities Facility Manager

6/20/13

DATE

Certification:

I certify under penalty of law that this Sewer System Management Plan, and the subparts contained herein, comply with the requirements set forth in the General Waste Discharge Requirements (WDRs) for Sanitary Sewer Systems, Order No. 2006-0003 and as amended by a Memorandum of Agreement executed on June 27, 2006 between the Executive Director of the SWRCB and the California Water Environment Association. I further certify that this document and all attachments were prepared under the National Park Service's direction and supervision in accordance with its policies and procedures to assure that qualified personnel properly provided, evaluated, and incorporated the information reflected in this document, that the information included in this document is, to the best of my knowledge and belief, true, accurate, and complete.

Don Neubacher

Don Neubacher, Park Superintendent

6/21/13

DATE

YOSEMITE NATIONAL PARK UTILITIES BRANCH

SEWER SYSTEM MANAGEMENT PLAN EL PORTAL SANITARY SEWER SYSTEM (CS 5SSO10735)

TABLE OF CONTENTS

SECTION 1: GOALS	7
1.1 REGULATORY REQUIREMENTS FOR THE GOAL ELEMENT	8
1.2 EL PORTAL SANITARY SEWER COLLECTION SYSTEM GOALS.....	8
SECTION 2: ORGANIZATION	9
2.1 REGULATORY	10
2.2 MANAGEMENT	11
2.3 RESPONSIBLE AUTHORIZED REPRESENTATIVE	11
2.3.1 DESCRIPTION OF RESPONSIBILITIES	13
2.4 CHAIN OF COMMUNICATION FOR SSO REPORTING	14
2.5 ORGANIZATIONAL CHART.....	18
SECTION 3: LEGAL AUTHORITY	19
3.1 REGULATORY	20
3.2 AUTHORITY OVER ILLICIT DISCHARGE PREVENTION	23
3.3 AUTHORITY OVER PROPER DESIGN AND CONSTRUCTION.....	23
3.4 AUTHORITY OF ACCESS FOR MAINTENANCE, INSPECTION AND REPAIRS	23
3.5 AUTHORITY TO LIMIT DISCHARGE OF FATS, OILS & GREASE (FOG) AND DEBRIS.....	24
3.6 AUTHORITY TO ENFORCE ANY VIOLATION OF SEWER AGREEMENT.....	24
SECTION 4: OPERATION AND MAINTENANCE PROGRAM	29
4.1 REGULATORY REQUIREMENTS	30
4.2 MAPPING	31
4.2.1 MAP UPDATES	32
4.3 ROUTINE PREVENTATIVE OPERATIONS AND MAINTENANCE PLAN.....	42

YOSEMITE NATIONAL PARK UTILITIES BRANCH

SEWER SYSTEM MANAGEMENT PLAN EL PORTAL SANITARY SEWER SYSTEM (CS 5SSO10735)

4.3.1	SYSTEMS OPERATIONS DESCRIPTION	42
A.	THE EL PORTAL MAINTENANCE COMPLEX	42
B.	THE RANCHERIA FLAT	43
C.	THE TRAILER COURT (ALSO REFERRED TO AS TRAILER PARK)	43
D.	OLD EL PORTAL	43
E.	THE YOSEMITE VIEW LODGE	44
F.	EL PORTAL WASTEWATER TREATMENT FACILITY	44
4.3.2	GRAVITY SEWER CLEANING AND INSPECTION SCHEDULE	45
4.3.3	LIFT STATION CLEANING AND INSPECTION SCHEDULE	58
4.3.4	FORCE MAIN CLEANING AND INSPECTION SCHEDULE	62
4.3.5	OIL / WATER SEPARATOR CLEANING AND INSPECTION SCHEDULE	63
4.3.6	SEWER SYSTEM EQUIPMENT AND REPLACEMENT PARTS INVENTORY	64
4.3.7	TRAINING REQUIREMENTS	65
4.4	REHABILITATION AND REPLACEMENT PLAN	69
4.4.1	SEWER CONDITION INSPECTION AND ASSESSMENT	69
4.4.2	CAPITAL IMPROVEMENT PLAN	83
SECTION 5: DESIGN AND PERFORMANCE PROVISIONS		111
5.1	DESIGN STANDARDS	112
5.1.1	GRAVITY SEWER MAINS	112
5.1.2	MANHOLES	115
5.1.3	SERVICE LATERALS	116
5.1.4	PRESSURE SEWER	117
5.1.5	LIFT STATION	118
5.2	STANDARD DRAWINGS	123
5.3	CONSTRUCTION SPECIFICATIONS	123

YOSEMITE NATIONAL PARK UTILITIES BRANCH

SEWER SYSTEM MANAGEMENT PLAN EL PORTAL SANITARY SEWER SYSTEM (CS 5SSO10735)

SECTION 6: OVERFLOW EMERGENCY RESPONSE PLAN.....	197
6.1 CALIFORNIA SPECIFIC NOTIFICATION AND REPORTING REQUIREMENTS	199
6.2 SSO DETECTION WITHIN EL PORTAL.....	203
6.3 EL PORTAL SSO RESPONSE.....	203
6.3.1 USRO RESPONSE.....	203
6.3.2 USRO DATA COLLECTION.....	210
A. SPILL VOLUMES.....	210
B. ENVIRONMENTAL SAMPLING.....	212
6.4 EL PORTAL SSO REPORTING REQUIREMENTS.....	213
6.5 RECORD KEEPING AND OTHER PUBLIC NOTIFICATION	216
6.6 FAILURE ANALYSIS INVESTIGATION	217
6.7 BASIC EMERGENCY RESPONSE EQUIPMENT AND SUPPLIES	218
6.8 SSO RESPONSE TRAINING.....	219
SECTION 7: FOG CONTROL PROGRAM	231
7.1 REGULATORY REQUIREMENTS FOR THE FOG CONTROL PROGRAM ELEMENT	232
7.2 NATURE AND EXTENT OF FOG PROBLEM.....	233
7.3 CLEANING SCHEDULE FOR IDENTIFIED FOG PRONE SEWER SEGMENTS.....	234
7.4 PUBLIC OUTREACH PROGRAM	235
7.5 FOG REMOVAL DISPOSAL FACILITIES.....	235
7.6 FOG SOURCE CONTROL MEASURES	237
7.6.1 PROHIBITED DISCHARGES.....	238
7.6.2 REQUIREMENTS TO INSTALL GREASE REMOVAL DEVICES	239
7.6.3 FOG PREVENTATIVE MAINTENANCE	239
7.7 DESIGN, MAINTENANCE AND RECORD KEEPING.....	241
7.7.1 DESIGN STANDARDS FOR GREASE REMOVAL DEVICES	241

YOSEMITE NATIONAL PARK UTILITIES BRANCH

SEWER SYSTEM MANAGEMENT PLAN EL PORTAL SANITARY SEWER SYSTEM (CS 5SSO10735)

7.7.2	MAINTENANCE REQUIREMENTS	241
7.7.3	RECORD KEEPING REQUIREMENTS.....	243
7.7.4	BEST MANAGEMENT PRACTICES REQUIREMENTS.....	243
SECTION 8: SYSTEM EVALUATION AND CAPACITY ASSURANCE PLAN.....		245
8.1	CAPACITY ASSURANCE PROGRAM REQUIREMENTS.....	246
8.2	CAPACITY EVALUATION	247
8.2.1	GENERAL.....	247
8.2.2	THEORETICAL SEWER FLOW MODEL.....	250
8.2.3	ACTUAL SEWER FLOW MEASUREMENT	257
8.2.4	INFILTRATION AND INFLOW CONSIDERATIONS	261
8.2.5	SITE SPECIFIC PROCEDURES FOR MEASURING SEWER FLOWS AT RANCHERIA FLAT, TRAILER COURT, OLD EL PORTAL AND YOSEMITE VIEW LODGE	264
A.	SEWER COLLECTION BASIN NO. 1 – MAINTENANCE AREA	267
B.	SEWER COLLECTION – RANCHERIA FLAT	267
B.I	SEWER COLLECTION BASIN NO. 2 – RANCHERIA FLAT	268
B.II	SEWER COLLECTION BASIN NO. 3 – RANCHERIA FLAT	268
B.III	SEWER COLLECTION BASIN NO. 4 – RANCHERIA FLAT	269
C.	SEWER COLLECTION BASIN NO. 5 – TRAILER COURT	269
D.	SEWER COLLECTION – OLD EL PORTAL.....	271
D.I	SEWER COLLECTION BASIN NO. 6 – OLD EL PORTAL.....	271
D.II	SEWER COLLECTION BASIN NO. 7 – OLD EL PORTAL.....	272
E.	SEWER COLLECTION BASIN NO. 8 – YOSEMITE VIEW LODGE	273
8.3	COMPARISON OF FIELD MEASUREMENTS AND DESIGN CRITERIA	274
8.4	SEWER ENHANCEMENT	274
8.5	SCHEDULE	275

YOSEMITE NATIONAL PARK UTILITIES BRANCH

SEWER SYSTEM MANAGEMENT PLAN EL PORTAL SANITARY SEWER SYSTEM (CS 5SSO10735)

SECTION 9: MONITORING, MEASUREMENT AND PROGRAM MODIFICATIONS	283
9.1 REGULATORY REQUIREMENTS FOR THE MONITORING, MEASUREMENT AND PROGRAM MODIFICATIONS ELEMENT	284
9.2 PERFORMANCE MEASURES	285
9.3 HISTORICAL PERFORMANCE DATA	288
9.4 BASELINE PERFORMANCE	290
9.5 PERFORMANCE MONITORING AND PROGRAM CHANGES	291
9.6 SSMP UPDATES	292
SECTION 10: SSMP PROGRAM AUDIT	293
10.1 REGULATORY REQUIREMENTS	294
10.2 SSMP AUDITS	294
SECTION 11: COMMUNICATION PROGRAM	305
11.1 REGULATORY REQUIREMENT	306
11.2 COMMUNICATING DEVELOPMENT AND IMPLEMENTATION	306
11.3 COMMUNICATING SEWER SYSTEM PERFORMANCE	307
11.4 EDUCATIONAL INFORMATION	308
SECTION 12: CERTIFICATION OF COMPLIANCE	309
12.1 REGULATORY REQUIREMENTS FOR CERTIFICATION OF COMPLIANCE	310
SECTION 13: RATE ANALYSIS	313
13.1 DIRECTOR’S ORDER PURPOSE AND REQUIREMENTS	314
13.2 DETERMINATION OF RATE STRUCTURES	314
13.3 COLLECTION SYSTEM COSTS	319
13.3.1 SYSTEM OPERATION AND MAINTENANCE COSTS (RECOVERY OF O&M COSTS)	320
A. ROUTINE MANHOLE INSPECTION COST RECOVERY	321
B. ROUTINE SEWER LINE CLEANING COST RECOVERY	323

YOSEMITE NATIONAL PARK UTILITIES BRANCH

SEWER SYSTEM MANAGEMENT PLAN EL PORTAL SANITARY SEWER SYSTEM (CS 5SSO10735)

C.	ROUTINE LIFT STATION INSPECTION & MAINTENANCE COST RECOVERY	324
C.I	DAILY / WEEKLY ROUTINE LIFT STATION INSPECTION COST RECOVERY	325
C.II	MONTHLY ROUTINE LIFT STATION INSPECTION COST RECOVERY	327
C.III	QUARTERLY ROUTINE LIFT STATION INSPECTION COST RECOVERY	329
C.IV	BI-ANNUAL ROUTINE LIFT STATION INSPECTION COST RECOVERY	331
C.V	ANNUAL ROUTINE LIFT STATION INSPECTION COST RECOVERY	333
D.	OIL / WATER SEPARATOR CLEANING AND INSPECTION COST RECOVERY	335
D.I	OIL / WATER SEPARATOR INSPECTION COST RECOVERY	335
D.II	OIL / WATER SEPARATOR SLUDGE REMOVAL COST RECOVERY	336
D.III	OIL / WATER SEPARATOR LEAK TEST COST RECOVERY	336
E.	TRAINING, ENERGY & PARTS, MATERIALS SUPPLIES, TOOLS, VEHICLE TOOL COST RECOVERY	337
13.3.2	COMPONENT RENEWAL (RECOVERY OF FM-PMIS PROJECT WORK COSTS)	338
13.3.3	RECAPITALIZATION / CAPITAL IMPROVEMENT COSTS (FY 2012 TO PRESENT)	338
13.3.4	CAPITAL IMPROVEMENT PLAN FUTURE COSTS	339
13.3.5	O&M, COMPONENT RENEWAL AND CAPITAL IMPROVEMENT COST SUMMARY	340
GLOSSARY		343
APPENDIX A: FOG CONTROL SUPPLEMENT		361
	FATS, OILS & GREASE (FOG) CONTROL SUPPLEMENT	362
	RIGHTS OF INSPECTION AND SAMPLING	372
APPENDIX B: UTILITY RATE COMPUTATION SUMMARY		375

YOSEMITE NATIONAL PARK UTILITIES BRANCH

SEWER SYSTEM MANAGEMENT PLAN EL PORTAL SANITARY SEWER SYSTEM (CS 5SSO10735)

1.0 GOALS

This section of the SSMP presents the YOSE's goals for the management, operation, and maintenance of its wastewater collection system.

YOSEMITE NATIONAL PARK UTILITIES BRANCH

SEWER SYSTEM MANAGEMENT PLAN EL PORTAL SANITARY SEWER SYSTEM (CS 5SSO10735)

1.1 REGULATORY REQUIREMENTS FOR THE GOAL ELEMENT

The goal of the SSMP is to provide a plan and schedule to properly manage, operate, and maintain all parts of the sanitary sewer system. This will help reduce and prevent SSOs, as well as mitigate any SSOs that do occur.

1.2 EL PORTAL SANITARY SEWER COLLECTION SYSTEM GOALS

YOSE has identified the following goals for the El Portal sanitary sewer collection system:

1. Reduce and prevent SSOs within the collection system; particularly in the Old El Portal and Rancheria Flats communities and also including the Trailer Park Court.
2. Maintain an effective and timely SSO Prevention and Response Plan.
3. Maintain a preventative maintenance program that includes regular inspection and maintenance of all YOSE-owned sewer collection infrastructures.
4. Develop an accurate database to determine and prioritize areas of major maintenance or rehabilitation needs.
5. Implement an effective Fats, Oils and Grease (FOG) Control Program.
6. Implement an adequate Sewer Collection Rehabilitation Program.
7. Provide adequate sewer capacity to accommodate current and projected uses.
8. Develop a public outreach program addressing SSO prevention and the importance of sewer collection infrastructure.
9. Provide a safe work environment for all operators of the collection system.

YOSEMITE NATIONAL PARK UTILITIES BRANCH

SEWER SYSTEM MANAGEMENT PLAN EL PORTAL SANITARY SEWER SYSTEM (CS 5SSO10735)

2.0 ORGANIZATION

YOSEMITE NATIONAL PARK UTILITIES BRANCH

SEWER SYSTEM MANAGEMENT PLAN

EL PORTAL

SANITARY SEWER SYSTEM (CS 5SSO10735)

2.1 REGULATORY

The Organization described in this section is to protect public health and the environment as required by the California State Water Resources Control Board (SWRCB) Order No. 2006-0003, Statewide General Discharge Requirements for Sanitary Sewer Systems. The SWRCB Order No. 2006-0003 requires the Organization section of the SSMP to contain at least the following elements:

- A. The name of the responsible or authorized representative as described below as found in Section J of the State Order for SSMP document.

Section J. – REPORT OF DECLARATION

1. All applications, reports, or information shall be signed and certified as follows:
 - a. All reports required by this Order and other information required by the State or Regional Water Board shall be signed and certified by a person designated, for a municipality, state, federal or other public agency, as either a principal executive officer or ranking elected official, or by a duly authorized representative of that person, as described in paragraph (ii) of this provision. (For purposes of electronic reporting, an electronic signature and accompanying certification, which is in compliance with the Online SSO database procedures, meet this certification requirement.)
 - b. An individual is a duly authorized representative only if:
 - i. The authorization is made in writing by a person described in paragraph (a) of this provision; and
 - ii. The authorization specifies either an individual or a position having responsibility for the overall operation of the regulated facility or activity.

YOSEMITE NATIONAL PARK UTILITIES BRANCH

SEWER SYSTEM MANAGEMENT PLAN

EL PORTAL

SANITARY SEWER SYSTEM (CS 5SSO10735)

- B. The names and telephone numbers for management, administrative, and maintenance positions responsible for implementing specific measures in the SSMP program. The SSMP must identify lines of authority through an organization chart or similar document with a narrative explanation; and
- C. The chain of communication for reporting SSOs, from receipt of a complaint or other information, including the person responsible for reporting SSOs to the State and Regional Water Board and other agencies if applicable (such as County Health Officer, County Environmental Health Agency, Regional Water Board, and/or State Office of Emergency Services (OES)).

2.2 MANAGEMENT

Yosemite National Park (YNP) consists of six geographically separate sewer collection systems managed by YNP.

These are:

1. El Portal sewer collection system,
2. Hodgdon Meadow sewer collection system
3. Tuolumne Meadows sewer collection system,
4. Wawona sewer collection system,
5. White Wolf sewer collection system and
6. Yosemite Valley sewer collection system.

This SSMP specifically addresses the El Portal sewer collection system. YNP personnel provide the necessary operation and maintenance service for the El Portal sewer collection system.

2.3 RESPONSIBLE AUTHORIZED REPRESENTATIVE

The Utilities Facility Manager, manages all YNP sewer collection facility supervisors and is responsible for ensuring that the Park services are provided in accordance to this SSMP. The Superintendent of YNP has signatory & certification authority for all applications, reports, and implementations relative to this SSMP. The Utilities Facility Manager manages the YNP Personnel through the lines of authority represented in the organizational chart shown in Figure 2.2 presented in Section 2.5

YOSEMITE NATIONAL PARK UTILITIES BRANCH

SEWER SYSTEM MANAGEMENT PLAN EL PORTAL SANITARY SEWER SYSTEM (CS 5SSO10735)

Contact information with names and telephone numbers for management, administrative, and maintenance staff responsible for implementing specific measures in the SSMP program are provided in Table 2.1 below. Refer to Utilities Branch Personnel contact list for a complete listing of information.

**TABLE 2.1
SSMP Contact Information**

Name	Position	SSMP Element	Telephone Number	
			Office	Cell
Don Neubacher	Park Superintendent	Certifies SSO Reports	209-372-0201	
Paul Laymon	Utilities Facility Manager	All Elements Regulatory Reporting of SSOs	209-379-1077	209-756-8144
Jim Allen	Facility Management Specialist	All Elements	209-379-1039	559-760-1346
George Harders	USRO Supervisor El Portal Sewer Collection System and Wastewater Treatment Facility	O&M Program, Overflow Emergency Response Plan, FOG Control Program	209-379-1828	209-401-7385
YNP Emergency Dispatch	All risks Call Center		209-379-1992 209-379-1997	
Facility Management Customer Service Center	Facility Management Work Order Call-In		209-379-1058	

YOSEMITE NATIONAL PARK UTILITIES BRANCH

SEWER SYSTEM MANAGEMENT PLAN

EL PORTAL

SANITARY SEWER SYSTEM (CS 5SSO10735)

2.3.1 DESCRIPTION OF RESPONSIBILITIES

- Park Superintendent – Executive Officer as defined by State Water Quality Control Board. Responsible for providing written certified reports documenting SSO events.
- Utilities Facility Manager – Responsible for oversight of park USRO Supervisors and USRO personnel. Receives information regarding SSOs including status of event. Provides direction where needed. Provides regulatory notification. Submits Certified Reports to Park Superintendent.
- Engineering Branch – Responsible for design of infrastructure resulting in reduced probability of an SSO occurrence.
- Facilities Management Specialist – Assists Utilities Facility Manager with responsibilities for oversight of park USRO Supervisor and USRO personnel. Assist with receiving information regarding SSOs including status of event. Assists with providing direction where needed. Provides regulatory notification. Reports to Park Superintendent in absence of Utilities Facility Manager.
- USRO Supervisor – Coordinates information processing of SSO events between field and management personnel. Responds to and reports SSO event. Stops spill, recovers, cleans up, disinfects site and prepares report. Performs environmental sampling as warranted.
- YNP Emergency Dispatch – Receives and relays call with status to appropriate personnel to address SSO occurrences. Provides a YNP incident number for tracking and reporting purposes.
- USRO Leader and Personnel – Responds to and reports SSO event. Stops spill, recovers, cleans up, disinfects site and prepares report. Performs environmental sampling as warranted.

YOSEMITE NATIONAL PARK UTILITIES BRANCH

SEWER SYSTEM MANAGEMENT PLAN

EL PORTAL

SANITARY SEWER SYSTEM (CS 5SSO10735)

2.4 CHAIN OF COMMUNICATION FOR SSO REPORTING

The protocol or chain of communication for reporting SSOs, either through discovery or other investigative means and reporting to applicable regulatory agencies as well as courtesy notifications to downstream users of affected waters is discussed as follows and is presented diagrammatically in Figure 2.1 at the end of this section.

SSOs can be discovered either by the public, concessionaire, or park personnel. The chain of communication typically begins with YNP dispatch receiving a call from either the public, the park's contracted concessionaire, or park personnel. YNP dispatch subsequently notifies USRO personnel from an emergency contact list to respond to an SSO. Typically USRO O&M staff are first responders to an SSO incident however; USRO Supervisors may also be first responders. In either case, after an SSO has been determined and response staff arrive the chain of communication for reporting continues. Reporting and Notification of spills per NPS Reference Manual 83B4 commences. USRO O&M Staff will provide critical information to the USRO Supervisor and YNP dispatch such that the Supervisor can provide for correct and adequate resources to address the SSO and provide timely regulatory reporting. YNP Dispatch will generate and provide an incident number for tracking and reporting purposes. Spills to water bodies must be reported by the USRO Supervisor to Utilities Facility Manager for reporting to the California State Office of Emergency Services within two (2) hours of the spill. Category one spills must be reported by Utilities Facility Manager to State Water Resource Control Board (SWRCB) no later than three days. Utilities Facility Manager will submit a certified report to the Park Superintendent for submittal to SWRCB within fifteen days. In addition the Utilities Facility Manager will also notify the Regional Water Quality Control Board (Upon Request), Mariposa County Health Department, and Offices of Emergency Services (OES) within thirty days after the end of the month in which the spill occurred, for both category one and two spills. The USRO O&M Staff at the time of the spill will prepare the Yosemite Utilities Branch SSO Report containing site-specific spill data and information. Communication will continue up the Chain by USRO O&M Staff to the USRO Supervisor and Utilities Facility Manager as necessary if additional resources are required. The USRO Supervisor will monitor affected water bodies that the spill has entered and direct staff to take sampling of the water for further testing and regulatory reporting. The Merced River runs along and parallel with the El Portal's collection and treatment facility. If the spill reaches

YOSEMITE NATIONAL PARK UTILITIES BRANCH

SEWER SYSTEM MANAGEMENT PLAN EL PORTAL SANITARY SEWER SYSTEM (CS 5SSO10735)

Merced River waters, additional reporting is required to both Water Users and Public Access Facilities downstream. In addition, the Park provides courtesy calls to several downstream users.

These include:

Water Users

Mariposa PUD

- Mark Rowney, Mgr. 209-966-2515

Lake Don Pedro Community Services District

- Dan Tyan 209-852-2331

Lake McClure McSwain Reservoir Parks Department

- James Mills 209-378-2520

Public Access Facilities

Bagby Ranger (Bret Surdich) 209-376-4475

BLM Red Bud Boat Launch 209-966-3638

USFS Dry Gulch & Dirt Flap Campground 209-966-3638

BLM Ranger

- David Greenwood, Ranger (April – Labor Day) 209-379-2622
- Chuck Brazzel (Labor Day – March) 209-966-3192

CA Department of Fish & Game

- Frank D. Milazzo, Warden 209-966-3376

YOSEMITE NATIONAL PARK UTILITIES BRANCH

SEWER SYSTEM MANAGEMENT PLAN EL PORTAL SANITARY SEWER SYSTEM (CS 5SSO10735)

Courtesy Calls to Downstream Users

- Indian Flat 209-379-2339
- Cedar Lodge 209-379-2612
- Yosemite Redbud Lodge, Savages,
Trading Post and Sisachi Gallery 209-379-2301
- Mariposa County Sheriff 209-966-3614

The USRO O&M Staff will initiate site clean up and disinfection following USRO Supervisor approval. Communication will continue between the Utilities Facility Manager, USRO Supervisor and USRO O&M Staff to determine causes and corrective measures to prevent future SSOs at the same location.

FIGURE 2.1
YNP SSO Protocol or Chain of Communication Flow Chart

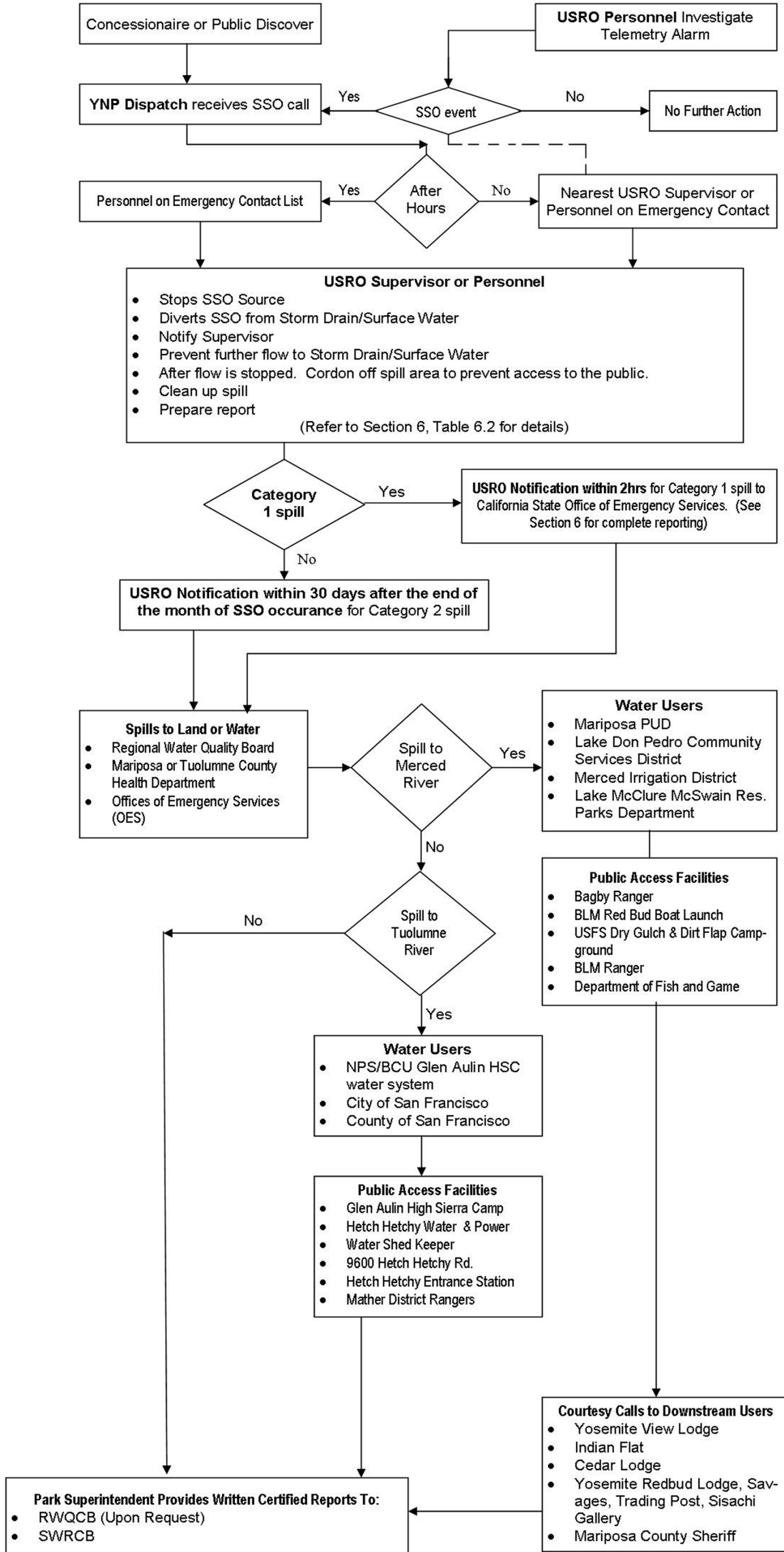
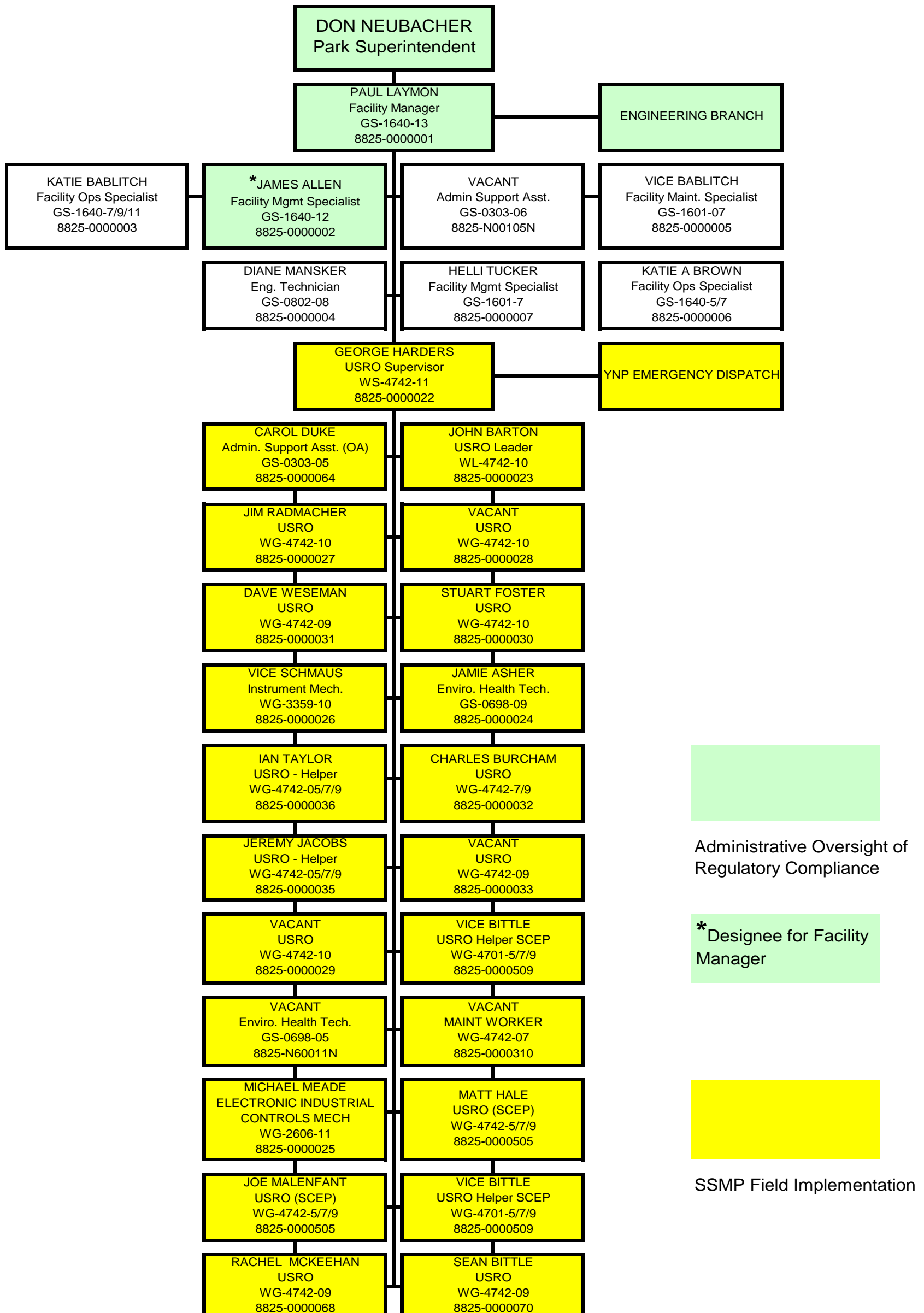

Figure 2.2 presents a detailed organizational chart for YNP's administrative, management and field personnel structure and relationship.

FIGURE 2.2
YNP Organizational Chart for EI Portal



YOSEMITE NATIONAL PARK UTILITIES BRANCH

SEWER SYSTEM MANAGEMENT PLAN EL PORTAL SANITARY SEWER SYSTEM (CS 5SSO10735)

3.0 LEGAL AUTHORITY

YOSEMITE NATIONAL PARK UTILITIES BRANCH

SEWER SYSTEM MANAGEMENT PLAN

EL PORTAL

SANITARY SEWER SYSTEM (CS 5SSO10735)

3.1 REGULATORY

The Legal Authority of the NPS to provide enforcement to protect public health and the environment as required by the California State Water Resources Control Board (SWRCB) Order No. 2006-0003, Statewide General Discharge Requirements for Sanitary Sewer Systems comes from the property clause of the U.S. Constitution, which is the supreme law of the United States and gives Congress the authority to develop laws governing the management of the National Park System (NPS). Through this authority Congress passed:

1. [NPS Organic Act of 1916](#) - Whereby the authority to issue a Director's Order is contained in 16 U.S.C. 1 through 4 (the National Park Service Organic Act), and Part 245 of the Department of the Interior Manual.
2. [NPS General Authorities Act of 1970](#)
3. [National Park Service Concessions Management Improvement Act of 1998](#)

Taken together, these three laws establish for NPS managers:

- A. A strict mandate to protect park resources and values.
- B. A responsibility to actively manage all park uses.
- C. Measures necessary to ensure the protection, conservation, and preservation of resources of the unit of the National Park System.

The highest of three levels of guidance documents in the NPS Directives is the System Service-wide policy articulated by the Director of the National Park Service. The 2006 edition of NPS Management Policies is the basic Service-wide policy document of the National Park Service, superseding the 2001 edition.

The second level of guidance documents are interim updates or amendments provided through director's orders which also serve as a vehicle to clarify or supplement the Management Policies to meet the needs of NPS managers. Any previously dated statement of policy not consistent with these Management Policies, or with a director's order that updates, amends, or clarifies policy, is to be disregarded.

YOSEMITE NATIONAL PARK UTILITIES BRANCH

SEWER SYSTEM MANAGEMENT PLAN

EL PORTAL

SANITARY SEWER SYSTEM (CS 5SSO10735)

The third level of guidance documents is the most detailed and provides comprehensive guidance on implementing Service-wide policy, which are usually in the form of handbooks or reference manuals issued by associate directors.

NPS employees must follow these guidance documents unless specifically waived or modified in writing by the Secretary, the Assistant Secretary, or the Director. Park superintendents will be held accountable for their and their staff's, adherence to Service-wide policies.

Other sources of Guidance come from instructions, guidance, and regional directives or otherwise-limited application supplementary to and in conformance with Service-wide policies that may be issued by regional directors or associate directors within formal delegations of authority. Superintendents may issue, within formal delegations of authority, park-specific instructions, procedures, directives, and other supplementary guidance, provided that the guidance does not conflict with Service-wide policy.

The above guidance documents provide NPS field employees with compilations of legal references, operating policies, standards, procedures, general information, recommendations, and examples to assist them in carrying out Management Policies and Director's Orders.

The National Park Service adheres to a number of principles through the 2006 edition of Management Policies. Some of the key principles are that the policies must:

- Comply with current laws, regulations and executive orders.
- Prevent impairment of park resources and values.
- Maintain NPS responsibility for making decisions and for exercising key authorities.
- Emphasize consultation and cooperation with local/state/tribal/federal entities.
- Support pursuit of the best contemporary business practices and sustainability.
- Employ a tone that leaves no room for misunderstanding the National Park Service's commitment to the public's appropriate use and enjoyment, including education and interpretation, of park resources, while preventing unacceptable impacts.

YOSEMITE NATIONAL PARK UTILITIES BRANCH

SEWER SYSTEM MANAGEMENT PLAN EL PORTAL SANITARY SEWER SYSTEM (CS 5SSO10735)

The National Park Service in Yosemite National Park demonstrates through the use of guidance documents legally binding procedures as it relates to the operation and maintenance of Yosemite's wastewater collection systems that the Park satisfies meeting the requirements put forth by the California State Water Resources Control Board (SWRCB) Order No. 2006-0003 Legal Authority section of the SSMP subsection (a) through (e) listed below.

The SWRCB Order No. 2006-0003 requires the Legal Authority section of the SSMP to contain at least the following elements:

- (a) Prevent illicit discharges into its sanitary sewer system (examples may include I/I, stormwater, chemical dumping, unauthorized debris and cut roots, etc.);
- (b) Require that sewers and connections be properly designed and constructed;
- (c) Ensure access for maintenance, inspection, or repairs for portions of the lateral owned or maintained by the Public Agency;
- (d) Limit the discharge of fats, oils, and grease and other debris that may cause blockages, and
- (e) Enforce any violation of its sewer ordinances.

Yosemite National Park (YNP) operates six geographically separate sewer collection systems:

- 1. El Portal sewer collection system,
- 2. Hodgdon Meadow sewer collection system,
- 3. Tuolumne Meadows sewer collection system,
- 4. Wawona sewer collection system,
- 5. White Wolf sewer collection system and
- 6. Yosemite Valley sewer collection system.

This SSMP specifically covers the El Portal sewer collection system as mapped in Figure 4.2 Section 4.

YOSEMITE NATIONAL PARK UTILITIES BRANCH

SEWER SYSTEM MANAGEMENT PLAN EL PORTAL SANITARY SEWER SYSTEM (CS 5SSO10735)

3.2 AUTHORITY OVER ILLICIT DISCHARGE PREVENTION

Permit operation of the wastewater treatment facility is governed by the California Waste Discharge Requirements Order R5-2008-0060, website link is presented in Exhibit 4.1 in Section 4. In addition to the permitting requirements, NPS operates under Director's Order #83: Public Health Reference Manual 83, Section B - Wastewater presented as Exhibit 3-1. It provides additional authority and guidance for the prevention of illicit discharge to the El Portal sewer collection and treatment system.

3.3 AUTHORITY OVER PROPER DESIGN AND CONSTRUCTION

The Utilities Branch of the Division of Facilities Management is responsible for management of the wastewater collection system servicing El Portal. The Design and Engineering Branch of the Division of Facilities Management works in coordination with the Utilities Branch in maintaining an operable system and is required by Director's Order #83: Public Health Reference Manual 83, Section B - Wastewater, sub-sections B.4 and B.5, to submit design plans and specifications to the Primacy Agency for approval, construction and installation in accordance with Primacy Agency requirements.

3.4 AUTHORITY OF ACCESS FOR MAINTENANCE, INSPECTION AND REPAIRS

Authority is granted under the Director's Order #83: Public Health Reference Manual 83 section B – Wastewater¹, to operate, maintain, inspect and repair wastewater systems including the residential areas owned and operated by the NPS for NPS staff and their respective families. In addition, Congress has provided the NPS with authority to enter into various types of agreements with private companies, corporations, groups, and individuals under Director's Order #20.

1 (Reference: <http://home.nps.gov/applications/npspolicy/DOrders.cfm>)

YOSEMITE NATIONAL PARK UTILITIES BRANCH

SEWER SYSTEM MANAGEMENT PLAN

EL PORTAL

SANITARY SEWER SYSTEM (CS 5SSO10735)

YNP currently contracts with a concessionaire to operate numerous facilities within the YNP sewer system whereby agreements to maintain, inspect and/or repair sewer improvements have been entered into. YNP currently does not have any facilities within the El Portal sewer system operated by a concessionaire. Currently there are private companies, corporations, groups, and individuals whereby agreements either have been or will be entered into to maintain, inspect and/or repair sewer improvements.

3.5 AUTHORITY TO LIMIT DISCHARGE OF FATS, OILS & GREASE (FOG) AND DEBRIS

There are commercial FOG sources (restaurants - vendors) that discharge into the El Portal wastewater collection system and there are also NPS residences and non-NPS residences that have some potential for producing FOG. Under the Director's Order #83: Public Health Reference Manual 83 section B – Wastewater, YNP has the authority to distribute educational information on minimizing FOG, proper disposal of FOG and other SSO prevention measures, including installation of backflow protection valves, service lateral maintenance, etc. disseminated through publication of an Annual Report, brochures, articles in NPS newsletters, the Park's webpage and individual notices to NPS residents. There is currently a FOG source control program operated under authority of Director's Order #83.

3.6 AUTHORITY TO ENFORCE ANY VIOLATION OF SEWER AGREEMENT

El Portal sewer system agreements are subject to authorized enforcement. Authority to enforce agreements is granted through the NPS' authority to enter into various types of agreements with private companies, corporations, groups, and individuals under Director's Order #20 and should incorporate Section 7 – FOG, Appendix "A" – FOG Control Supplement into an agreement. Enforcement authority also exists as granted under the Director's Order #83: Public Health Reference Manual 83 section B - Wastewater, to operate, maintain, inspect and repair wastewater systems.

YOSEMITE NATIONAL PARK UTILITIES BRANCH

SEWER SYSTEM MANAGEMENT PLAN EL PORTAL SANITARY SEWER SYSTEM (CS 5SSO10735)

EXHIBIT 3.1 Director's Order #83: Public Health

Approved: /s/ Donald W. Murphy (signed original on file) (for) Director

Effective Date: October 21, 2004

Sunset Date: October 21, 2010

The authority to issue this Director's Order is contained in 16 U.S.C. 1 through 4 (the National Park Service Organic Act), and Part 245 of the Department of the Interior Manual.

REFERENCE MANUAL 83B1 – WASTEWATER SYSTEMS

B. Wastewater

NPS unit managers will reduce the risk of waterborne diseases and provide safe wastewater disposal by ensuring wastewater systems are properly operated, maintained, monitored, and deficiencies promptly corrected. Wastewater systems will be in compliance with 1) the Clean Water Act, as amended (33 U.S.C. 1251 et seq or 2) the Primacy Agency (e.g. the agency designated by Federal law as having oversight responsibility). Additional guidance for non-public or other unregulated wastewater systems is provided in RM83(B1).

- B.1** NPS unit managers will ensure operators are adequately trained and certified in accordance with operator requirements of the Primacy Agency. Park managers will designate, in writing, primary operators, and backup operators who have adequate training and skills to operate the system(s). Parks that operate only individual, on-site wastewater systems will have appropriately trained operators.
- B.2** NPS unit managers will develop training plans and assure that operators receive any required and/or appropriate training.
- B.3** NPS unit managers will assure that required records are maintained in permanent files for periodic review by the PHC or Primacy Agency representatives and that reports are submitted on a timely basis as requested by the PHC and/or required by the Primacy Agency.
- B.4** When wastewater system modifications or new construction are proposed, parks will submit plans and specifications to the Primacy Agency for approval. A copy of the plans and specifications will be provided to the PHC.
- B.5** All wastewater facilities will be installed, operated and monitored in accordance with Primacy Agency requirements.

YOSEMITE NATIONAL PARK UTILITIES BRANCH

SEWER SYSTEM MANAGEMENT PLAN

EL PORTAL

SANITARY SEWER SYSTEM (CS 5SSO10735)

EXHIBIT 3.1 (Continued) **Director's Order #83: Public Health**

- B.6** Typical front country wastewater systems include flush toilets, vault toilets, and chemical toilets (used only for temporary purposes). Where conditions are suitable, alternate wastewater systems, such as composting and evaporative toilets may be considered for front country use. Park unit managers must contact the assigned Regional Public Health Consultant or Park Environmental Health Officer / Sanitarian for guidance and advice when planning to install, upgrade, or make substantive changes to any wastewater system. All wastewater systems must be installed and operated according to the manufacturer's instructions and in compliance with Primacy Agency requirements.
- B.7** Suitable backcountry waste systems include flush toilets; composting toilets; barrel toilets; evaporator toilets; incinerator toilets and pit privies. Pit privies should only be used as a last resort where other types of facilities are not possible. The Park Sanitarian or the PHC should conduct the siting of pit privies.
- B.8** All new vault toilets will incorporate the U.S. Forest Service Sweet Smelling Toilet (SST) design features. Vault toilets will be pumped as necessary. The U.S. Forest Service In-Depth Design and Maintenance Manual for Vault Toilets is provided in RM83(B2).
- B.9** All toilet facilities will be cleaned and re-supplied as often as necessary to maintain a high degree of sanitation. The U.S. Forest Service guidance manual Cleaning Recreation Sites is provided in RM83 (B3).
- B.10** Adequate sanitation facilities will be required for remote areas such as river rafting, horseback riding, back country biking, backpacking and similar activities in accordance with RM83(F).
- B.11** Septic tanks shall be inspected annually to determine the amount of accumulated scum and sludge. Records of septic tank measurements, inspections, and pumping will be available for review by the PHC. Septic tank risers will be provided for inspection holes to facilitate inspection and pumping. Septic tanks will be pumped when the scum and or sludge levels in the tank dictate (generally every 3-5 years). The bottom of the scum should never be closer than 3 inches to the bottom of the outlet device, and the top to the sludge layer should never be less than 8 inches from the bottom of the outlet device.
- B.12** Septic tank drain fields shall be surveyed annually during a high use period to identify system failures such as odors and surfacing wastewater. The drain field should be kept clear of trees and bushes, which may send roots into the drain field piping system resulting in clogging and causing premature failure.

YOSEMITE NATIONAL PARK UTILITIES BRANCH

SEWER SYSTEM MANAGEMENT PLAN EL PORTAL SANITARY SEWER SYSTEM (CS 5SSO10735)

EXHIBIT 3.1 (Continued) **Director's Order #83: Public Health**

- B.13** Personnel who routinely come into contact with sewage, work in, or inspect wastewater treatment facilities, lagoons, etc. will have a current immunization for tetanus.
- B.14** Wastewater treatment plant personnel will not eat, drink or smoke when performing maintenance or inspecting equipment, which may be contaminated with human sewage.
- B.15** In the event of a major wastewater leak or spill, the PHC will be notified within one business day. Facilities and equipment contaminated with sewage as a result of leaks, spills, and sewage system backflow will be thoroughly washed down with water and detergent. Further guidance is provided in RM83 (B4) - Raw Sewage Spill Notification and Cleanup.

YOSEMITE NATIONAL PARK UTILITIES BRANCH

SEWER SYSTEM MANAGEMENT PLAN EL PORTAL SANITARY SEWER SYSTEM (CS 5SSO10735)

This page left intentionally blank.

YOSEMITE NATIONAL PARK UTILITIES BRANCH

SEWER SYSTEM MANAGEMENT PLAN EL PORTAL SANITARY SEWER SYSTEM (CS 5SSO10735)

4.0 OPERATION AND MAINTENANCE PROGRAM

YOSEMITE NATIONAL PARK UTILITIES BRANCH

SEWER SYSTEM MANAGEMENT PLAN

EL PORTAL

SANITARY SEWER SYSTEM (CS 5SSO10735)

4.1 REGULATORY REQUIREMENTS

The National Park Service (NPS) has developed a comprehensive operations and maintenance (O&M) program for the Yosemite National Park (YNP) that adheres to the State Water Resource Control Board (SWRCB) Order No. 2006-0003. SWRCB Order No. 2006-0003 requires Sewer System Management Plans (SSMPs) to *“include provisions to provide proper and efficient management, operation, and maintenance of sanitary sewer systems, while taking into consideration risk management and cost benefit analysis.”*

The SWRCB Order further states SSMPs must include the following elements:

- **Mapping:** “Maintain an up-to-date map of the sanitary sewer system, showing all gravity line segments and manholes, pumping facilities, pressure pipes and valves, and applicable storm water conveyance facilities.”
- **Routine Preventative Operations and Maintenance Plan:** “Describe routine preventive operation and maintenance (O&M) activities by staff and contractors, including a system for scheduling regular maintenance and cleaning of the sanitary sewer system with more frequent cleaning and maintenance targeted at known problem areas. The Preventative Maintenance (PM) program should have a system to document scheduled and conducted activities, such as work orders.”
- **Rehabilitation and Replacement Plan:** “Develop a rehabilitation and replacement plan to identify and prioritize system deficiencies and implement short-term and long-term rehabilitation actions to address each deficiency. The program should include regular visual and TV inspections of manholes and sewer pipes, and a system for ranking the condition of sewer pipes and scheduling rehabilitation. Rehabilitation and replacement should focus on sewer pipes that are at risk of collapse or prone to more frequent blockages due to pipe defects. Finally, the rehabilitation and replacement plan should include a capital improvement plan that addresses proper management and protection of the infrastructure assets. The plan shall include a time schedule for implementing the short- and long-term plans plus a schedule for developing the funds needed for the capital improvement plan.”

YOSEMITE NATIONAL PARK UTILITIES BRANCH

SEWER SYSTEM MANAGEMENT PLAN

EL PORTAL

SANITARY SEWER SYSTEM (CS 5SSO10735)

- Personnel Training Requirements: “Provide training on a regular basis for staff in sanitary sewer system operations and maintenance, and require contractors to be appropriately trained.”
- System Equipment and Replacement Parts Inventory: “Provide equipment and replacement part inventories, including identification of critical replacement parts.”

4.2 MAPPING

The Design and Engineering Branch of the Facilities Management Division has developed and maintains AutoCAD mapping for the sanitary sewer collection system illustrating all gravity piping, manholes, cleanouts, oil water separators, and wastewater treatment facilities that include septic tanks and subsurface drain fields. The vicinity map for El Portal is presented in Figure 4.1 and the layout of the sewer system for El Portal and its developed area is shown in Figure 4.2. The five distinct developed areas of El Portal include:

1. The El Portal Maintenance Complex,
2. Rancheria Flat,
3. Trailer Court or Trailer Park,
4. Old El Portal, and
5. Yosemite View Lodge.

The developed areas are mapped in Figures 4.3 through 4.9.

YOSEMITE NATIONAL PARK UTILITIES BRANCH

SEWER SYSTEM MANAGEMENT PLAN

EL PORTAL

SANITARY SEWER SYSTEM (CS 5SSO10735)

4.2.1 MAP UPDATES

Maps are updated annually or as needed with official electronic versions available from the Design and Engineering Branch. Mapping updates are typically performed following new construction when project contractors provide as built drawings along with the project's operational and maintenance manuals to the Design and Engineering Branch. However, since project designs are often not interrelated with existing facility components, USRO staff should ensure the completed construction project(s) are surveyed by the Design and Engineering Branch for accurate map placement. Additionally, USRO staff should report to the Design and Engineering Branch of alterations to existing facilities that also require map updating. GIS sewer maps for El Portal and its developed area are presently not available. Electronic versions of maps are stored and maintained by Facilities Management Division, branch of Design and Engineering.

4/13/13 15:44 SETH R18 G:\CLIENTS\NPS\10-0380C\YOSE\PMIS\DRAWINGS\CIVL\F4.1_VCL_EL_PO.DWG XREFS: G:\CLIENTS\NPS\10-0380C\YOSE\PMIS\DRAWINGS\BASES\YOSEBASE.DWG

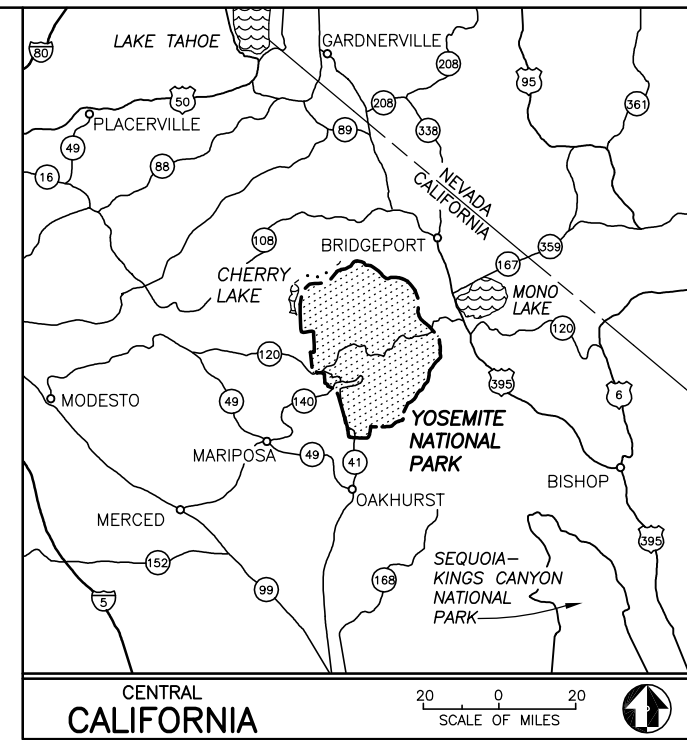
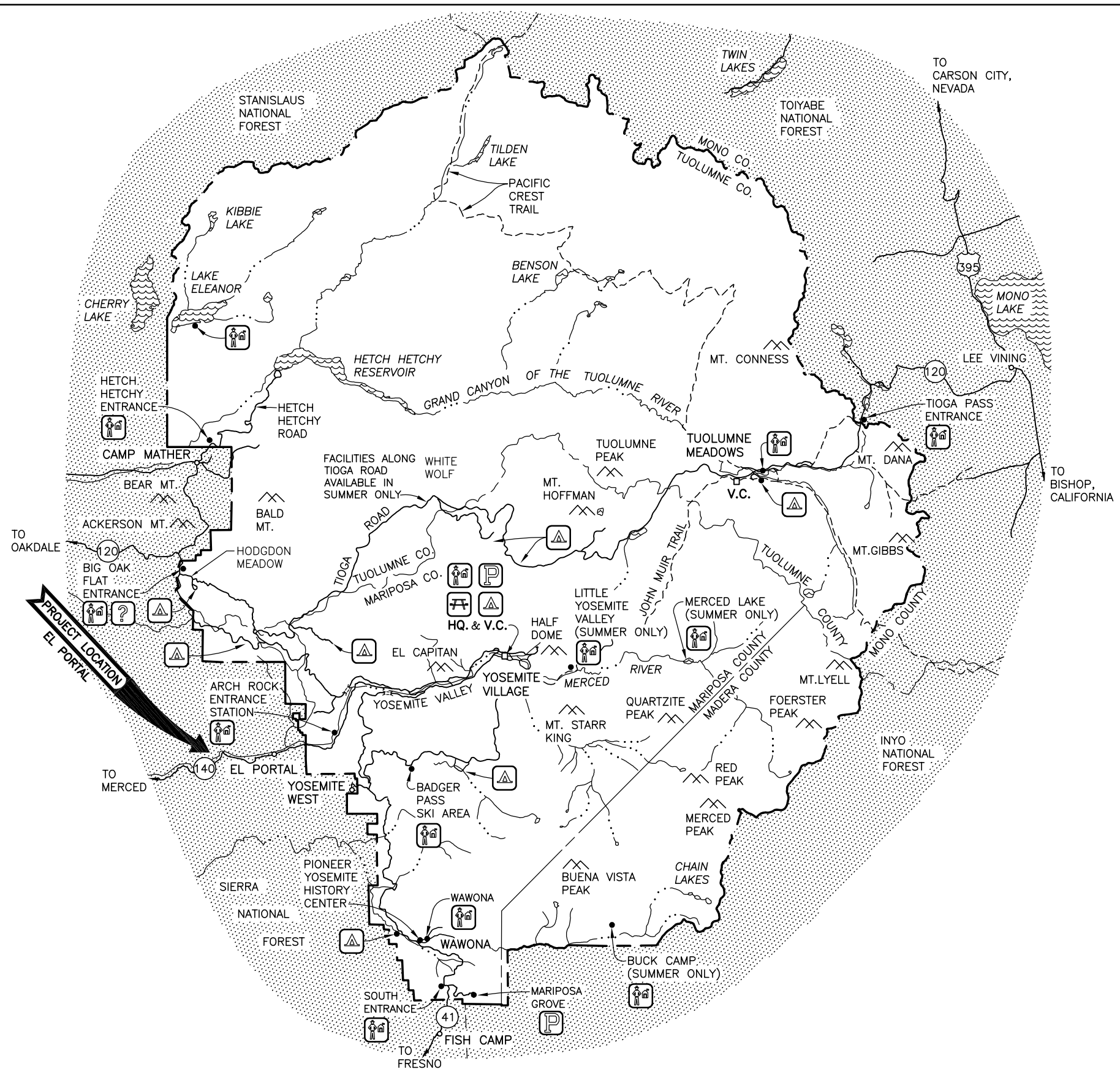

- LEGEND**
- PARK BOUNDARY
 - STATE LINE
 - COUNTY LINE
 - PAVED ROAD
 - TRAIL
 - RIVER OR CREEK
 - V.C. VISITOR CENTER
 - HQ. PARK HEADQUARTERS
 - RANGER STATION
 - INFORMATION CENTER
 - PARKING
 - PICNIC AREA
 - CAMPGROUND

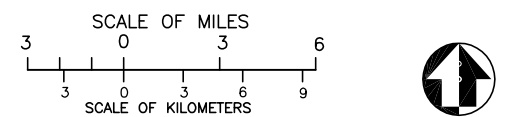

YOSEMITE NATIONAL PARK
WORLD HERITAGE SITE

FIGURE 4.1 - VICINITY MAP
SANITARY SEWER MANAGEMENT PLAN
EL PORTAL
YOSEMITE NATIONAL PARK

BASIC DATA: USGS TOPO MAP; PARK MINI FOLDER 1987; REVISED & REDRAWN 3/93. UPDATED 11/98. SGS.

DATE: 4/2013

4/2/13 17:05 SEH R18 G:\CLIENTS\NPS\10-0380C\YOSE\PMIS\DRAWINGS\CIV\F4-2-4.16_SITE_EL_PD.DWG XREFS: G:\CLIENTS\NPS\10-0380C\YOSE\PMIS\DRAWINGS\BASES\ELPORTAL.DWG; G:\CLIENTS\NPS\10-0380C\YOSE\PMIS\DRAWINGS\BASES\EP_UTIL.DWG;

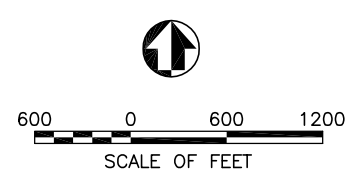
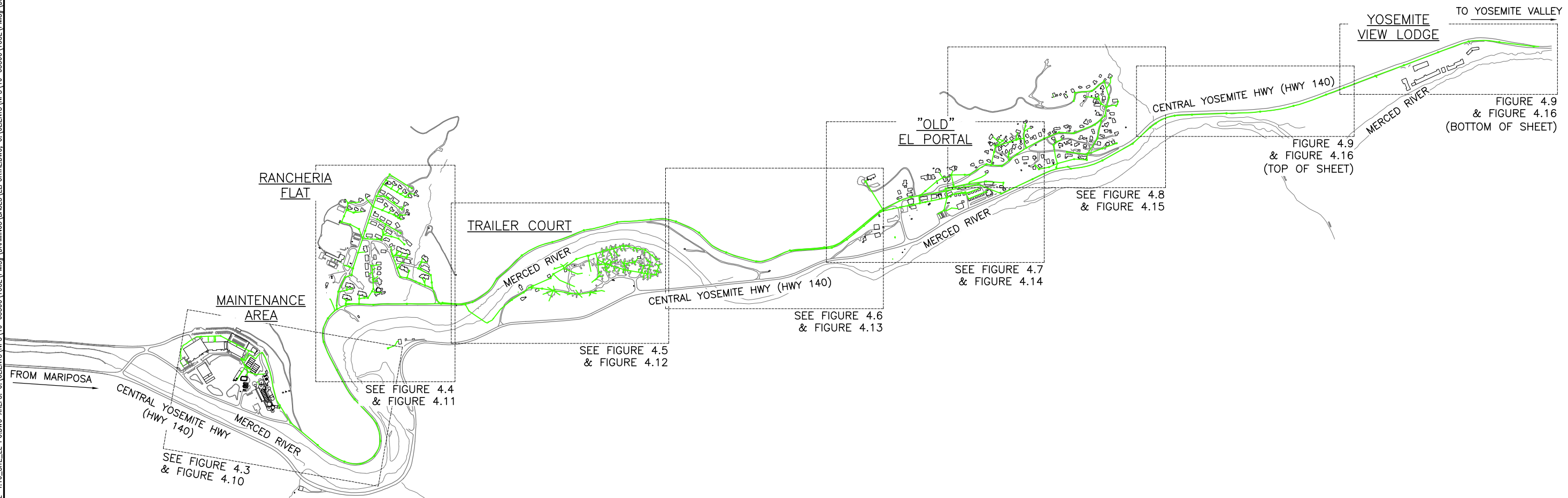
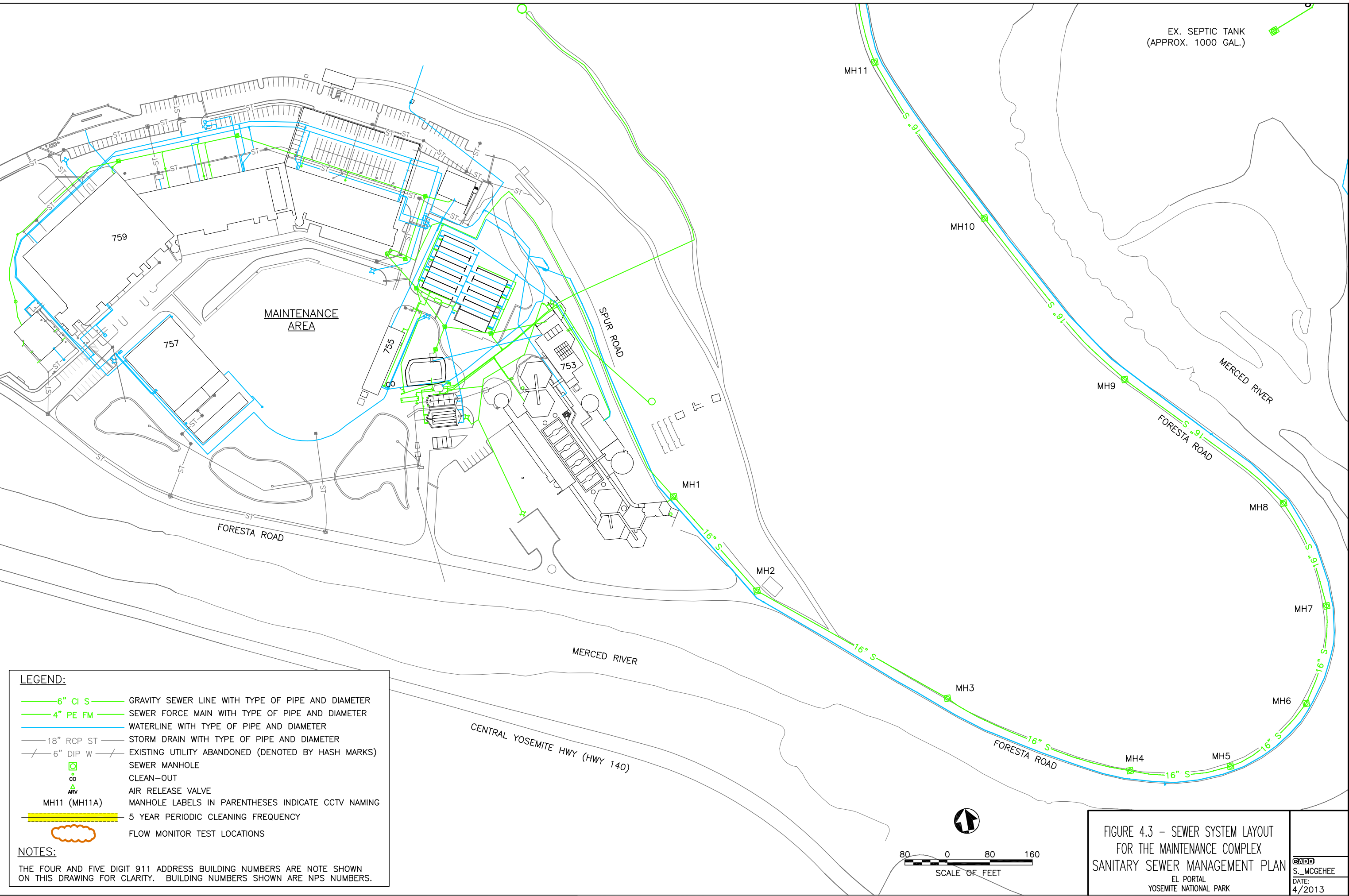

FIGURE 4.2 - SITE MAP	
SANITARY SEWER MANAGEMENT PLAN	
EL PORTAL YOSEMITE NATIONAL PARK	
GADD S._MCGEEHEE	DATE: 4/2013

4/2/13 17:05 SEH R18 G:\CLIENTS\NPS\10-0380C\YOSE\PMIS\DRAWINGS\CIV\F4-2-4.16_SITE_EL_PD.DWG_XREFS: G:\CLIENTS\NPS\10-0380C\YOSE\PMIS\DRAWINGS\BASES\EL\PORTAL.DWG: G:\CLIENTS\NPS\10-0380C\YOSE\PMIS\DRAWINGS\BASES\EP-UTILS.DWG:



EX. SEPTIC TANK
(APPROX. 1000 GAL.)

LEGEND:

- 6" CI S GRAVITY SEWER LINE WITH TYPE OF PIPE AND DIAMETER
- 4" PE FM SEWER FORCE MAIN WITH TYPE OF PIPE AND DIAMETER
- WATERLINE WITH TYPE OF PIPE AND DIAMETER
- 18" RCP ST STORM DRAIN WITH TYPE OF PIPE AND DIAMETER
- - - 6" DIP W EXISTING UTILITY ABANDONED (DENOTED BY HASH MARKS)
- SEWER MANHOLE
- CLEAN-OUT
- △ AIR RELEASE VALVE
- MH11 (MH11A) MANHOLE LABELS IN PARENTHESES INDICATE CCTV NAMING
- 5 YEAR PERIODIC CLEANING FREQUENCY
- FLOW MONITOR TEST LOCATIONS

NOTES:
THE FOUR AND FIVE DIGIT 911 ADDRESS BUILDING NUMBERS ARE NOTE SHOWN ON THIS DRAWING FOR CLARITY. BUILDING NUMBERS SHOWN ARE NPS NUMBERS.

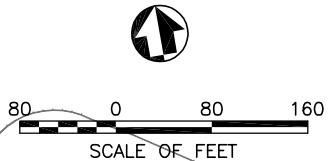
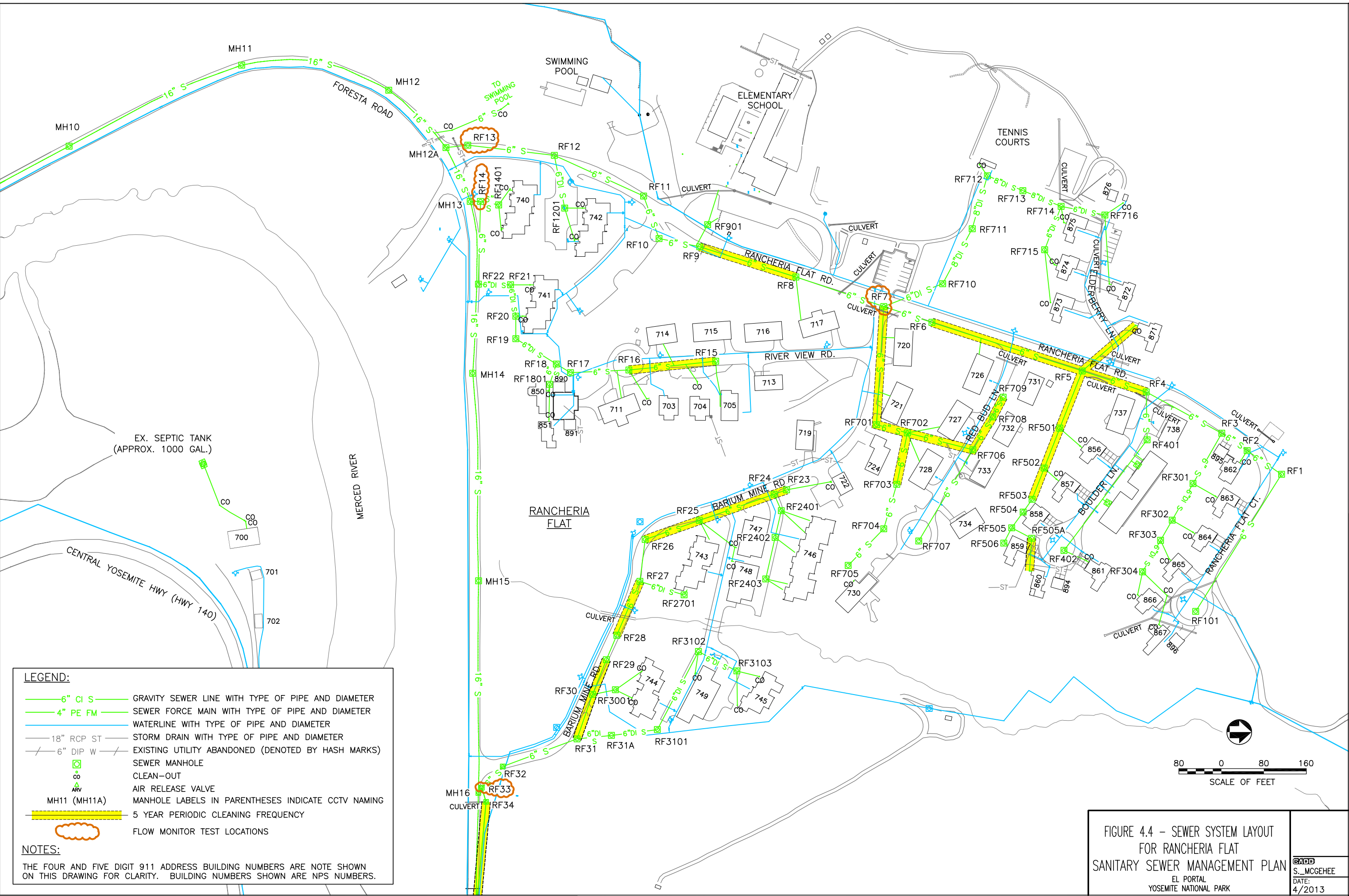

FIGURE 4.3 - SEWER SYSTEM LAYOUT FOR THE MAINTENANCE COMPLEX
SANITARY SEWER MANAGEMENT PLAN
EL PORTAL
YOSEMITE NATIONAL PARK

CSADD
S. MCGEEHEE
DATE:
4/2013

4/2/13 17:05 SEH R18 G:\CLIENTS\NPS\10-0380C\YOSEMITE NATIONAL PARK\DRAWINGS\CIVIL\F4-2-4.16_SITE_EL_PODWG.XREFS: G:\CLIENTS\NPS\10-0380C\YOSEMITE NATIONAL PARK\DRAWINGS\BASES\EL PORTAL.DWG: G:\CLIENTS\NPS\10-0380C\YOSEMITE NATIONAL PARK\DRAWINGS\BASES\EP-UTILS.DWG:



LEGEND:

- 6" CI S GRAVITY SEWER LINE WITH TYPE OF PIPE AND DIAMETER
- 4" PE FM SEWER FORCE MAIN WITH TYPE OF PIPE AND DIAMETER
- WATERLINE WITH TYPE OF PIPE AND DIAMETER
- 18" RCP ST STORM DRAIN WITH TYPE OF PIPE AND DIAMETER
- - - 6" DIP W EXISTING UTILITY ABANDONED (DENOTED BY HASH MARKS)
- SEWER MANHOLE
- CLEAN-OUT
- △ AIR RELEASE VALVE
- MH11 (MH11A) MANHOLE LABELS IN PARENTHESES INDICATE CCTV NAMING
- 5 YEAR PERIODIC CLEANING FREQUENCY
- FLOW MONITOR TEST LOCATIONS

NOTES:
 THE FOUR AND FIVE DIGIT 911 ADDRESS BUILDING NUMBERS ARE NOTE SHOWN ON THIS DRAWING FOR CLARITY. BUILDING NUMBERS SHOWN ARE NPS NUMBERS.

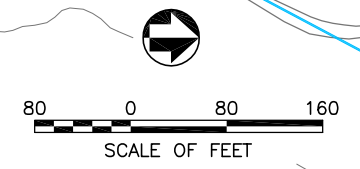

FIGURE 4.4 - SEWER SYSTEM LAYOUT FOR RANCHERIA FLAT
 SANITARY SEWER MANAGEMENT PLAN
 EL PORTAL
 YOSEMITE NATIONAL PARK

GADD
 S. MCGEEHEE
 DATE:
 4/2013

4/2/13 17:05 SEH R18 G:\CLIENTS\NPS\10-0380C\YOSE\PMIS\DRAWINGS\CIV\F4-2-4.16_SITE_EL_PODWG.XREFS: G:\CLIENTS\NPS\10-0380C\YOSE\PMIS\DRAWINGS\BASES\EL\PORTAL.DWG: G:\CLIENTS\NPS\10-0380C\YOSE\PMIS\DRAWINGS\BASES\EP-UTILS.DWG:

LEGEND:

- 6" CI S GRAVITY SEWER LINE WITH TYPE OF PIPE AND DIAMETER
- 4" PE FM SEWER FORCE MAIN WITH TYPE OF PIPE AND DIAMETER
- WATERLINE WITH TYPE OF PIPE AND DIAMETER
- 18" RCP ST STORM DRAIN WITH TYPE OF PIPE AND DIAMETER
- - - 6" DIP W EXISTING UTILITY ABANDONED (DENOTED BY HASH MARKS)
- SEWER MANHOLE
- CLEAN-OUT
- ▲ ARV AIR RELEASE VALVE
- MH11 (MH11A) MANHOLE LABELS IN PARENTHESES INDICATE CCTV NAMING
- 5 YEAR PERIODIC CLEANING FREQUENCY
- FLOW MONITOR TEST LOCATIONS

NOTES:

THE FOUR AND FIVE DIGIT 911 ADDRESS BUILDING NUMBERS ARE NOTE SHOWN ON THIS DRAWING FOR CLARITY. BUILDING NUMBERS SHOWN ARE NPS NUMBERS.

NO CCTV RESULTS FOR TRAILER COURT.

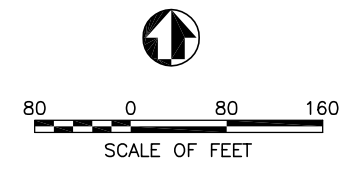
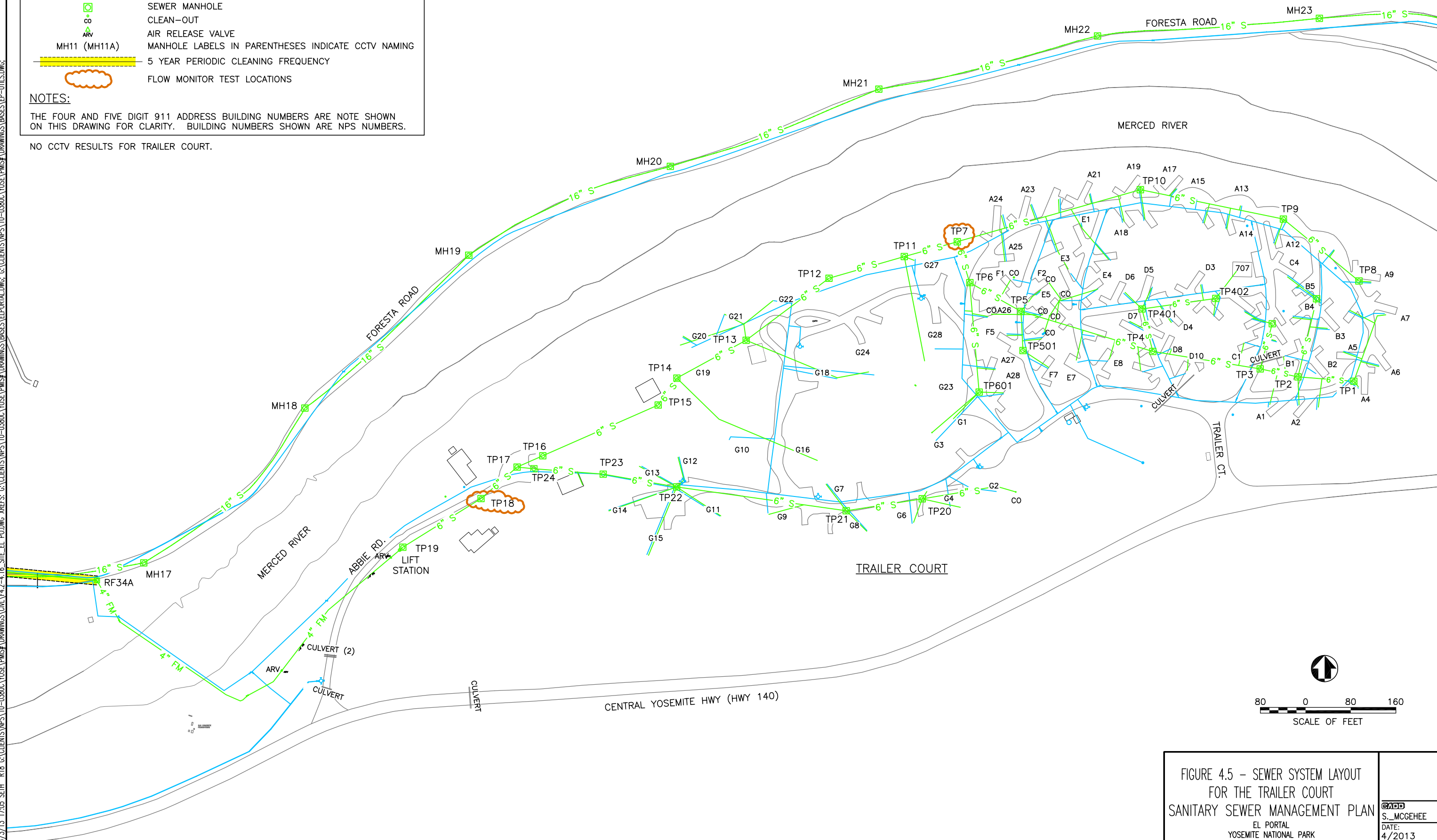

FIGURE 4.5 – SEWER SYSTEM LAYOUT FOR THE TRAILER COURT
SANITARY SEWER MANAGEMENT PLAN
 EL PORTAL
 YOSEMITE NATIONAL PARK

GA
S. MCGEEHEE
DATE:
4/2013

4/2/13 17:05 SEH R18 G:\CLIENTS\NPS\10-0380C\YOSE\PMIS\DRAWINGS\CIV\F4-2-4.16_SITE_EL_PORTAL.DWG G:\CLIENTS\NPS\10-0380C\YOSE\PMIS\DRAWINGS\BASES\EP-UTILS.DWG

LEGEND:

- 6" CI S — GRAVITY SEWER LINE WITH TYPE OF PIPE AND DIAMETER
- 4" PE FM — SEWER FORCE MAIN WITH TYPE OF PIPE AND DIAMETER
- — WATERLINE WITH TYPE OF PIPE AND DIAMETER
- 18" RCP ST — STORM DRAIN WITH TYPE OF PIPE AND DIAMETER
- - - 6" DIP W - - - EXISTING UTILITY ABANDONED (DENOTED BY HASH MARKS)
- — SEWER MANHOLE
- — CLEAN-OUT
- ▲ — AIR RELEASE VALVE
- MH11 (MH11A) — MANHOLE LABELS IN PARENTHESES INDICATE CCTV NAMING
- 5 YEAR PERIODIC CLEANING FREQUENCY
- — FLOW MONITOR TEST LOCATIONS

NOTES:

THE FOUR AND FIVE DIGIT 911 ADDRESS BUILDING NUMBERS ARE NOT SHOWN ON THIS DRAWING FOR CLARITY. BUILDING NUMBERS SHOWN ARE NPS NUMBERS.

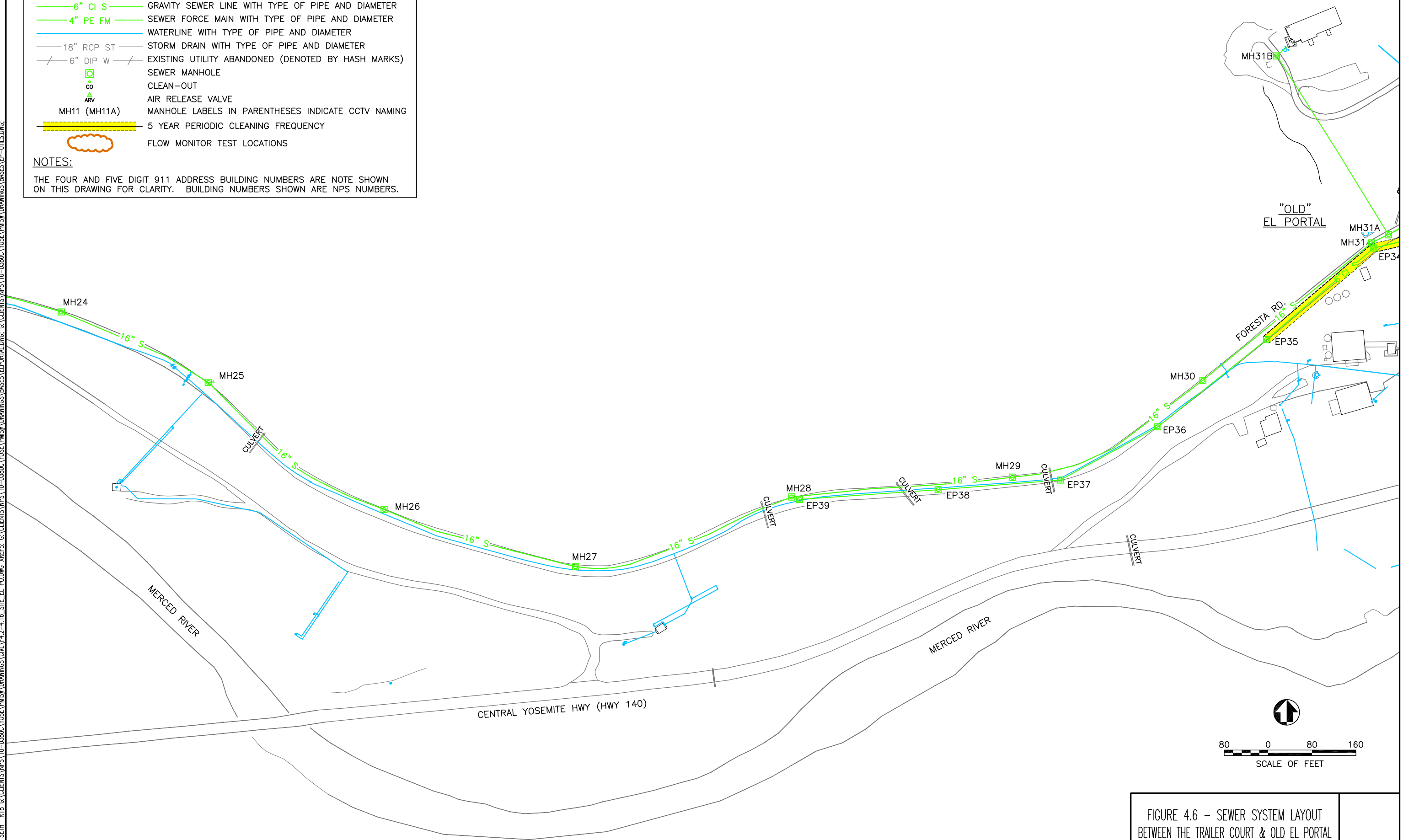

**FIGURE 4.6 - SEWER SYSTEM LAYOUT
BETWEEN THE TRAILER COURT & OLD EL PORTAL
SANITARY SEWER MANAGEMENT PLAN**

EL PORTAL
YOSEMITE NATIONAL PARK

CAED S._MCGEEHEE	DATE: 4/2013
----------------------------	-----------------

LEGEND:

- 6" CI S GRAVITY SEWER LINE WITH TYPE OF PIPE AND DIAMETER
- 4" PE FM SEWER FORCE MAIN WITH TYPE OF PIPE AND DIAMETER
- WATERLINE WITH TYPE OF PIPE AND DIAMETER
- 18" RCP ST STORM DRAIN WITH TYPE OF PIPE AND DIAMETER
- - - 6" DIP W EXISTING UTILITY ABANDONED (DENOTED BY HASH MARKS)
- SEWER MANHOLE
- CLEAN-OUT
- ▲ ARV AIR RELEASE VALVE
- MH11 (MH11A) MANHOLE LABELS IN PARENTHESES INDICATE CCTV NAMING
- 5 YEAR PERIODIC CLEANING FREQUENCY
- FLOW MONITOR TEST LOCATIONS

NOTES:

THE FOUR AND FIVE DIGIT 911 ADDRESS BUILDING NUMBERS ARE NOTE SHOWN ON THIS DRAWING FOR CLARITY. BUILDING NUMBERS SHOWN ARE NPS NUMBERS.

4/2/13 17:05 SEH R18 G:\CLIENTS\NPS\10-0380C\YOSE\PMIS\DRAWINGS\CIV\F4-2-4.16_SITE_EL_PODWG.XREFS: G:\CLIENTS\NPS\10-0380C\YOSE\PMIS\DRAWINGS\BASES\ELPORTAL.DWG: G:\CLIENTS\NPS\10-0380C\YOSE\PMIS\DRAWINGS\BASES\EP_UTIL.DWG:

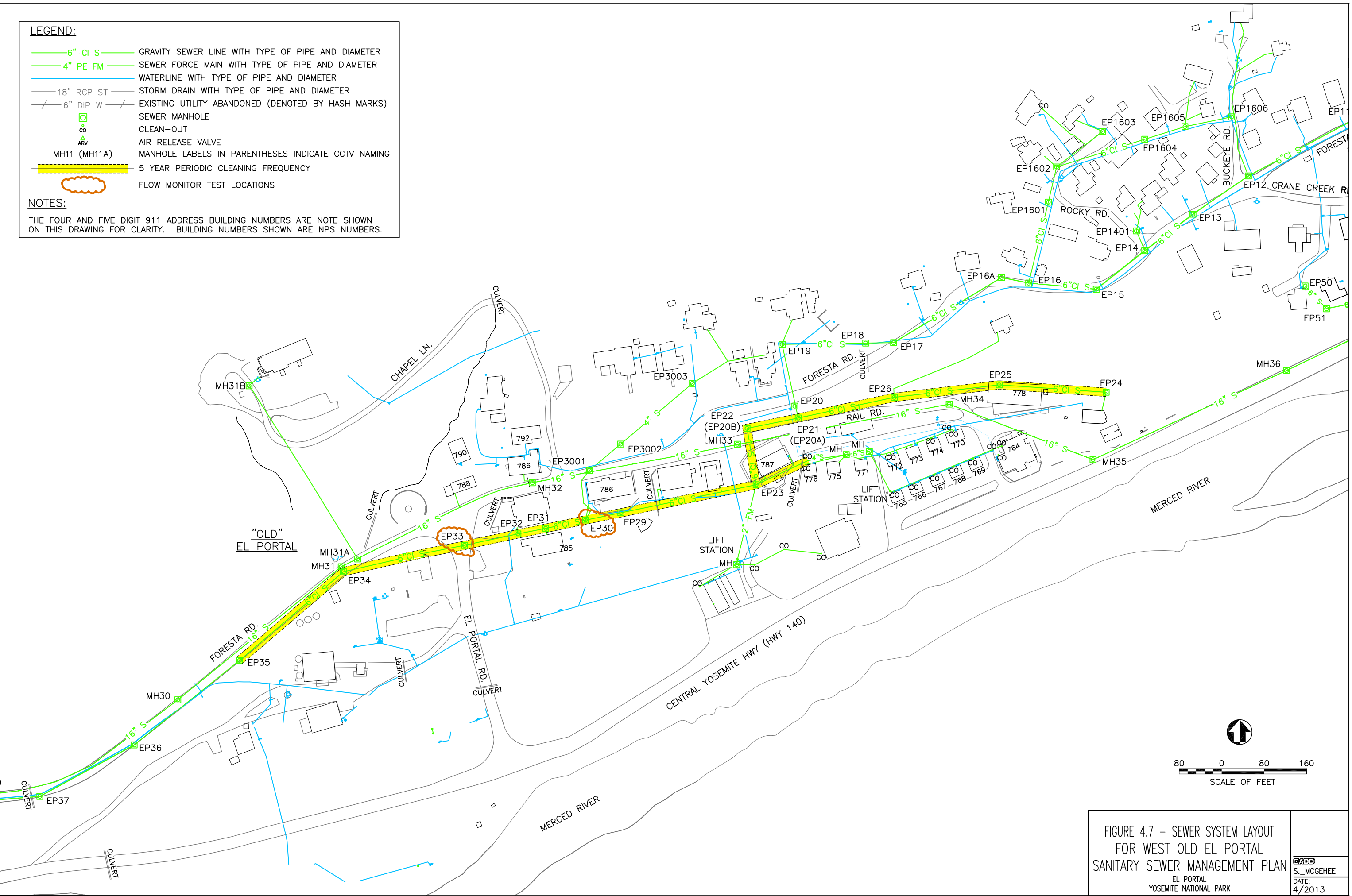

FIGURE 4.7 – SEWER SYSTEM LAYOUT FOR WEST OLD EL PORTAL
SANITARY SEWER MANAGEMENT PLAN
EL PORTAL
YOSEMITE NATIONAL PARK

GADD
S. MCGEEHEE
DATE:
4/2013

4/2/13 17:05 SETH R18 G:\CLIENTS\NPS\10-0380C\YOSE\PMIS\DRAWINGS\CIV\F4-2-4.16_SITE_EL_PORTAL.DWG XREFS: G:\CLIENTS\NPS\10-0380C\YOSE\PMIS\DRAWINGS\BASES\EL_PORTAL.DWG G:\CLIENTS\NPS\10-0380C\YOSE\PMIS\DRAWINGS\BASES\EP_UTIL.DWG

LEGEND:

- 6" CI S GRAVITY SEWER LINE WITH TYPE OF PIPE AND DIAMETER
- 4" PE FM SEWER FORCE MAIN WITH TYPE OF PIPE AND DIAMETER
- WATERLINE WITH TYPE OF PIPE AND DIAMETER
- 18" RCP ST STORM DRAIN WITH TYPE OF PIPE AND DIAMETER
- - - 6" DIP W EXISTING UTILITY ABANDONED (DENOTED BY HASH MARKS)
- SEWER MANHOLE
- CLEAN-OUT
- △ ARV AIR RELEASE VALVE
- MH11 (MH11A) MANHOLE LABELS IN PARENTHESES INDICATE CCTV NAMING
- 5 YEAR PERIODIC CLEANING FREQUENCY
- FLOW MONITOR TEST LOCATIONS

NOTES:

THE FOUR AND FIVE DIGIT 911 ADDRESS BUILDING NUMBERS ARE NOTE SHOWN ON THIS DRAWING FOR CLARITY. BUILDING NUMBERS SHOWN ARE NPS NUMBERS.

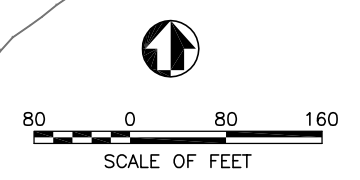
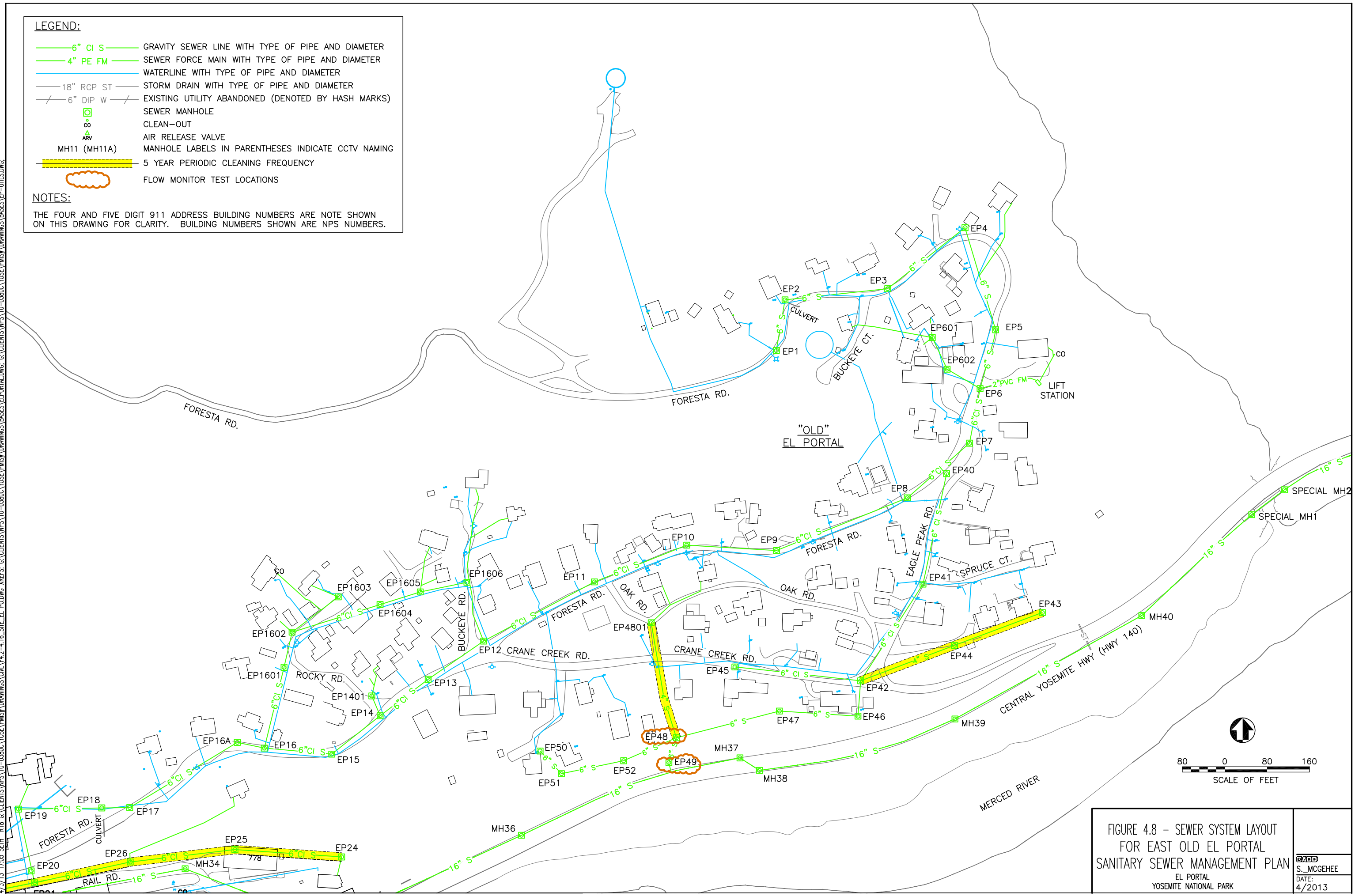

FIGURE 4.8 - SEWER SYSTEM LAYOUT FOR EAST OLD EL PORTAL SANITARY SEWER MANAGEMENT PLAN
 EL PORTAL
 YOSEMITE NATIONAL PARK

GADD S. MCGEEHEE	DATE: 4/2013
---------------------	-----------------

4/2/13 17:05 SETH R18 G:\CLIENTS\NPS\10-0380C\YOSE\PMIS\DRAWINGS\CIV\F4-2-4.16_SITE_EL_PODWG.XREFS G:\CLIENTS\NPS\10-0380C\YOSE\PMIS\DRAWINGS\BASES\EP-UTILS.DWG; G:\CLIENTS\NPS\10-0380C\YOSE\PMIS\DRAWINGS\BASES\ELPORTAL.DWG; G:\CLIENTS\NPS\10-0380C\YOSE\PMIS\DRAWINGS\BASES\EP-UTILS.DWG;

LEGEND:

- 6" CI S — GRAVITY SEWER LINE WITH TYPE OF PIPE AND DIAMETER
- 4" PE FM — SEWER FORCE MAIN WITH TYPE OF PIPE AND DIAMETER
- WATERLINE WITH TYPE OF PIPE AND DIAMETER
- 18" RCP ST — STORM DRAIN WITH TYPE OF PIPE AND DIAMETER
- - - 6" DIP W - - - EXISTING UTILITY ABANDONED (DENOTED BY HASH MARKS)
- SEWER MANHOLE
- ∞ CLEAN-OUT
- ▲ ARV AIR RELEASE VALVE
- MH11 (MH11A) MANHOLE LABELS IN PARENTHESES INDICATE CCTV NAMING
- 5 YEAR PERIODIC CLEANING FREQUENCY
- FLOW MONITOR TEST LOCATIONS

NOTES:

THE FOUR AND FIVE DIGIT 911 ADDRESS BUILDING NUMBERS ARE NOTE SHOWN ON THIS DRAWING FOR CLARITY. BUILDING NUMBERS SHOWN ARE NPS NUMBERS.

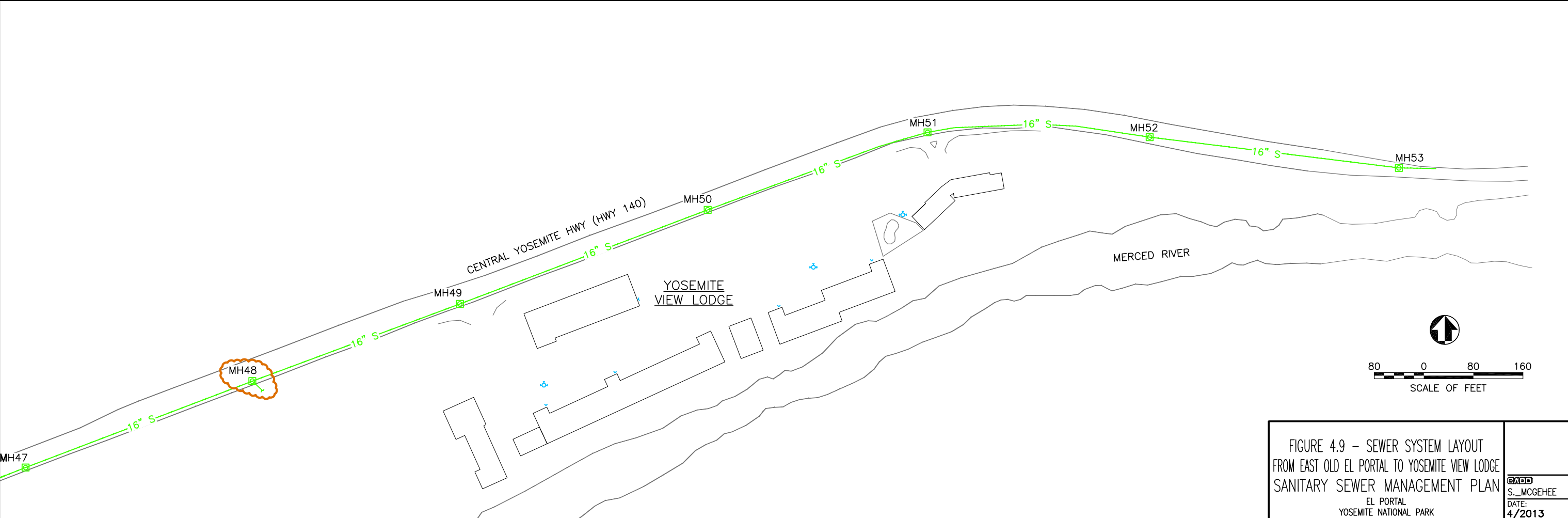
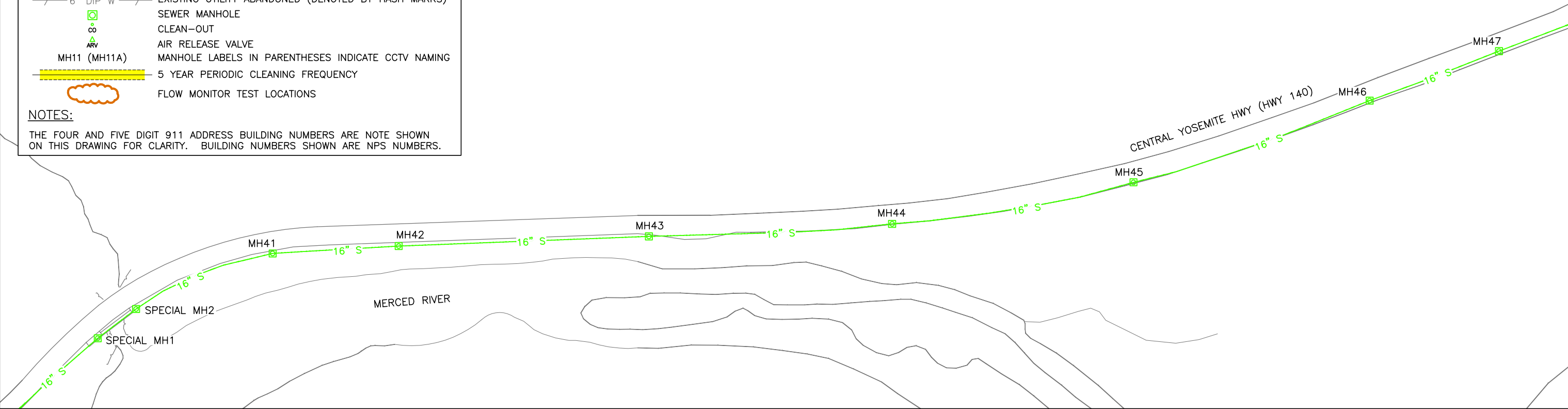

FIGURE 4.9 – SEWER SYSTEM LAYOUT FROM EAST OLD EL PORTAL TO YOSEMITE VIEW LODGE
 SANITARY SEWER MANAGEMENT PLAN
 EL PORTAL
 YOSEMITE NATIONAL PARK

SADD
 S._MCGEEHEE
 DATE:
 4/2013

YOSEMITE NATIONAL PARK UTILITIES BRANCH

SEWER SYSTEM MANAGEMENT PLAN

EL PORTAL

SANITARY SEWER SYSTEM (CS 5SSO10735)

4.3 ROUTINE PREVENTATIVE OPERATIONS AND MAINTENANCE PLAN

A routine and systematic operation and maintenance program is an essential element in the management of a wastewater collection system. This requires effective sewer system inspections, cleaning, and documentation as discussed below for optimizing the sewer collection system and to prevent sewer system overflows (SSOs). The Utilities Branch of the Division of Facilities Management is responsible for management of the wastewater collection system servicing El Portal and its developed area.

4.3.1 SYSTEMS OPERATIONS DESCRIPTION

The sanitary sewer collection and treatment system for El Portal consists of five distinct sewer collection systems and one wastewater treatment system as mapped in Section 4.2. All wastewater generated from the five distinct developed areas are discharged into the sewer main coming from Yosemite Valley and piped to the El Portal wastewater treatment system for final wastewater treatment and disposal; except, sewer from the El Portal Maintenance Complex is directly pumped and piped to the wastewater treatment facility. Manholes (MH #1 through MH #58) are part of the sewer main from Yosemite Valley and are assessed and included in the SSMP for El Portal and its developed area.

A. THE EL PORTAL MAINTENANCE COMPLEX

The sewer collection system within the El Portal Maintenance Complex, as mapped in Figure 4.3, services various administrative and maintenance facilities supporting YNP activities. The facilities include park administration buildings, vehicle and equipment storage, warehouses for material storage, and various maintenance shops to support roads and trails, high voltage, telecom, forestry, locksmith, signs, building and grounds, historic preservation, and vehicle maintenance.

The sewer system for the maintenance complex includes approximately 5 manholes, 1150 linear feet (lf) of 6-inch diameter gravity sewer main, an oil/water separator in the equipment maintenance facility, a lift station with 350 lf of 3 inch diameter force main that pumps wastewater from the administrative offices to a manhole near the northern corner of building 759, and a lift station with 400 lf of 4 inch diameter force main that

YOSEMITE NATIONAL PARK UTILITIES BRANCH

SEWER SYSTEM MANAGEMENT PLAN

EL PORTAL

SANITARY SEWER SYSTEM (CS 5SSO10735)

pumps all Maintenance Complex wastewater to the El Portal wastewater treatment facility.

B. THE RANCHERIA FLAT

The Rancheria Flat sewer system as mapped in Figure 4.4, services approximately 62 apartment units, 42 single family dwellings; community recreational facilities with tennis courts, ball field, and swimming pool, and a public school with library. There are no overnight camping facilities or commercial businesses within Rancheria Flat. The apartment units and single family dwellings within Rancheria Flat are 1 to 4 bedroom structures primarily utilized by NPS full-time and seasonal employees. The sewer system includes approximately 340 lf of 8-inch diameter piping, 6,750 lf 6-inch diameter piping, 75 lf of 4-inch diameter piping, and 77 manholes, based on asset inventories.

C. THE TRAILER COURT (ALSO REFERRED TO AS TRAILER PARK)

The Trailer Court area, also known as the Trailer Park (TP), as mapped in Figure 4.5, provides year-round and seasonal hook-ups for trailers and recreational vehicles largely for concession employees. There are approximately 20 permanent trailer homes with capacity to accommodate at least an additional 50 seasonal hookups. There are no commercial businesses within the Trailer Court area, except for a small coin-operated laundry facility. The sewer system within the Trailer Court consists of approximately 30 manholes, 4,120 lf of 6 inch diameter piping, and one sewer lift station with 350 lf of 4 inch diameter force main. The lift station consists of duplex 30 hp grinder pumps that conveys sewer from the Trailer Court to the sewer manhole RF 34A serving Rancheria Flat. A diesel powered generator is housed adjacent to the lift station for emergency use.

D. OLD EL PORTAL

The Old El Portal area as mapped in Figures 4.7 and 4.8 is the largest of the sewer service areas within El Portal and is comprised of various community services and housing for NPS and other park staff. Community services include fire station, community hall, post office, grocery and deli, park ranger station, Motor Inn cabins, chapel, fuel storage and distribution facility, fuel service station, and community park. There are approximately 80 residences within Old El Portal that are 2 and 3 bedroom

YOSEMITE NATIONAL PARK UTILITIES BRANCH

SEWER SYSTEM MANAGEMENT PLAN

EL PORTAL

SANITARY SEWER SYSTEM (CS 5SSO10735)

single residence structures. The sewer system consists of approximately 94 manholes, 40 lf of 3 inch diameter sewer laterals, 900 lf of 4 inch diameter gravity sewer piping, 8,000 lf of 6 inch diameter gravity sewer piping and four small sewer lift stations that service 1) the fuel storage and distribution facility, 2) ranger station, 3) the Old Hotel and Motor Inn Cabins, and 4) a residential area near building 5638.

E. THE YOSEMITE VIEW LODGE

The Yosemite View Lodge, as mapped in Figure 4.9, lies in the eastern sector of El Portal and provides tourist accommodations in a multi-story lodging complex that includes: 335 guest rooms and suites with kitchenettes, one indoor and three outdoor pools, indoor and several outdoor spas, two onsite restaurants, onsite laundry facility, and convenience store. Marketing brochures claim the Yosemite View Lodge can accommodate more guests than El Portal has residents; therefore, it is a significant contributor of wastewater to the sewer collection and treatment system. A description of the sewer system within Yosemite View Lodge area is not available and the Yosemite View Lodge is responsible for all SSOs that occur within its property boundaries. Sewer flows from the Yosemite View Lodge are discharged into MH 48 that flows westward to the El Portal wastewater treatment facility.

F. EL PORTAL WASTEWATER TREATMENT FACILITY

The El Portal wastewater treatment facility consists of grit removal and screening headworks, two primary clarifiers (one clarifier operational), a flow equalization tank, secondary treatment in three aeration tanks with two secondary clarifiers, and tertiary treatment by coagulation and flocculation followed by tube settling and filtration. The treated water is disinfected with ultraviolet light prior to discharge. Wastewater is discharged to the Merced River in accordance with the California Waste Discharge Requirements Order R5-2008-0060. El Portal normally discharges treated waters to percolation ponds for indirect discharge to Merced River, identified as outfall discharge D-001, but is also allowed to discharge directly into the Merced River via outfall discharge D-002 during high river flows that exceed maximum percolation pond levels. However, direct discharge to the Merced River rarely occurs except for emergencies or when the river stage or river water height exceeds maximum percolation pond water height.

YOSEMITE NATIONAL PARK UTILITIES BRANCH

SEWER SYSTEM MANAGEMENT PLAN EL PORTAL SANITARY SEWER SYSTEM (CS 5SSO10735)

4.3.2 GRAVITY SEWER CLEANING AND INSPECTION SCHEDULE

Physical sewer system inspections are vital to determine sewer cleaning program requirements as well as sewer system repairs. These inspections:

- Identify defects in the system that can potentially contribute to or cause backups, overflows, and bypasses.
- Identify chronic problem areas so maintenance or repairs can be planned and scheduled.
- Identify the needs for long-term replacement and rehabilitation.
- Help develop a baseline for future comparison to determine rates of deterioration.

SWRCB Order No 2006-0003 stipulates that the preventative maintenance program should have a system to document scheduled and conducted maintenance activities; therefore, the Utilities Branch utilizes IBM's MAXIMO software for its Facility Management Software System (FMSS) for managing preventative maintenance and the issuance of work orders to document scheduled and conducted preventative maintenance activities.

The following discussion of sewer inspections includes routine visual manhole inspections, and internal pipe inspections. These are used to plan and schedule the routine sanitary sewer cleanings of the system. The following Diagram 4.1 illustrates the relationship of sewer cleaning events, visual manhole inspections, and interior piping inspections.

YOSEMITE NATIONAL PARK UTILITIES BRANCH

SEWER SYSTEM MANAGEMENT PLAN

EL PORTAL

SANITARY SEWER SYSTEM (CS 5SSO10735)

DIAGRAM 4.1
Sewer Cleaning Scheduling Flowchart

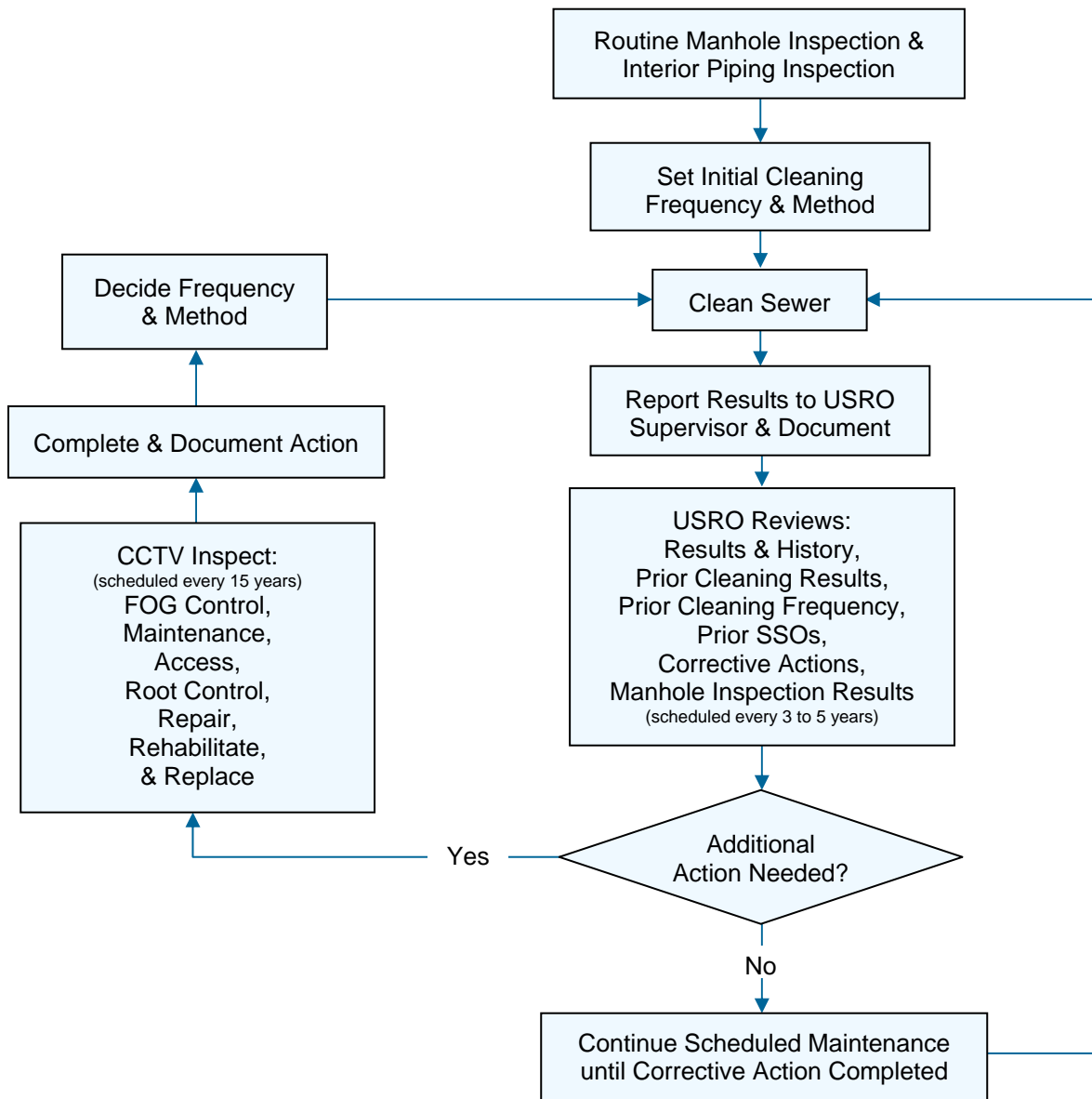

YOSEMITE NATIONAL PARK UTILITIES BRANCH

SEWER SYSTEM MANAGEMENT PLAN

EL PORTAL

SANITARY SEWER SYSTEM (CS 5SSO10735)

1. Routine Visual Manhole Inspection

Visual manhole inspections provide information and/or data that serve as indicators for the condition and functionality of the sewer collection system. The NPS plans to visually inspect every sewer manhole and cleanout in the El Portal wastewater collection system every five years except for the sewer main from Yosemite Valley to the El Portal Wastewater Treatment System inspected every three years with its Utility Systems Repairer Operator (USRO) staff. Visual inspections are performed more frequently on the sewer system manholes than internal piping inspections because of the relative ease of performance. However, more frequent manhole inspections may be required if infiltration, inflow, root growth, and/or other sewer problems are noted which may have the potential to cause an SSO or overload the wastewater treatment system. Routine manhole and cleanout inspections will include opening each manhole and cleanout in accordance with the schedule presented in Table 4.1. The results of these inspections shall be recorded on the Manhole Inspection form presented in Exhibit 4.2 and submitted to the USRO supervisor for further discussion/assessment to ascertain whether additional inspection, cleaning, and/or sewer rehabilitation is required. The development of Table 4.1 and the priority for re-inspections are based on the manhole inspection data collected during the October 2009 CCTV inspection program.

YOSEMITE NATIONAL PARK UTILITIES BRANCH

SEWER SYSTEM MANAGEMENT PLAN

EL PORTAL

SANITARY SEWER SYSTEM (CS 5SSO10735)

**TABLE 4.1
EI Portal Manhole and Cleanout Immediate Inspection Schedule (2013)**

Manhole or Cleanout Location	Asset Number	Manhole or Cleanout Location	Asset Number	Manhole or Cleanout Location	Asset Number
RF 101 ¹	1055250	EP 51	1055246	EP 48	1055244
RF 101 ¹	1056806	MH 32	NA	EP 50	1057135
EP 23	1055238	MH 34	NA	EP 52	1055247
EP 47	1057127	EP 45	1055243		

Re-inspect in three years depending upon inspection results.
Note 1: Manhole has multiple asset numbers.

The 7 manholes within the EI Portal Maintenance Complex are not numbered and do not have asset numbers. The manholes were not previously inspected during the 2009 CCTV inspection program. These manholes should be inspected during 2013 and re-inspected every three years based on the inspection results.

**TABLE 4.1 (Continued)
EI Portal Manhole and Cleanout Inspection Schedule (2013)**

Manhole or Cleanout Location	Asset Number	Manhole or Cleanout Location	Asset Number	Manhole or Cleanout Location	Asset Number
RF 707	1057030	RF 1201	1056808	TP 401	1057295
RF 710	1056811	RF 1401 ¹	1057261	TP 501	1057294
RF 713	1056818	RF 1401 ¹	1057262	TP 7	1057275
RF 716	1056841	RF 29	1055255	TP 10	1057277
RF 901 ¹	1056775	RF 31	NA	TP 13	1057272
RF 901 ¹	1056809	RF 3102	1057246	TP 16	1057268
RF 14	NA	RF 33	1055258	TP 19	1057265
RF 711	1056813	TP 1	1057292	TP 22	1057280
RF 714	1056834	TP3	1057289	EP 601	1057126

Note 1: Manhole has multiple asset numbers.

YOSEMITE NATIONAL PARK UTILITIES BRANCH

SEWER SYSTEM MANAGEMENT PLAN

EL PORTAL

SANITARY SEWER SYSTEM (CS 5SSO10735)

TABLE 4.1 (Continued)
El Portal Manhole and Cleanout Inspection Schedule (2014)

Manhole or Cleanout Location	Asset Number	Manhole or Cleanout Location	Asset Number	Manhole or Cleanout Location	Asset Number
RF 21	1057227	TP 15	1057271	MH 40	1057142
RF 22	1057203	TP 18	1057264	MH 43	NA
RF 712	1056842	TP 21	1057282	MH 46	NA
RF 715	1057027	TP 24	1057279	MH 49	NA
RF 20	1057228	MH 48	NA	MH 52	NA
RF 2701	1057249	MH 1	NA	MH 55	NA
RF 31A	1057245	MH 4	NA	MH 58	NA
RF 3103	1057247	MH 7	NA	MH 11	NA
TP 2	1057291	EP 27	1057098	MH 14	1057182
TP 301	1057298	MH 2	NA	MH 17	1057178
TP 402	1057296	MH 5	NA	MH 20	1057173
TP 6	1057284	MH 8	NA	MH 23	1057169
TP8	1057278	EP 1604	1057122	MH 26	1057160
TP 11	1057274	EP 25	1057113	MH 29	1057157
TP 14	1057270	EP 28	1057095	MH 38	1057148
TP 17	1057267	MH 3	NA	MH 41	NA
TP 20	1057283	MH 6	NA	MH 44	NA
TP 23	1057281	MH 9	NA	MH 47	NA
RF 3101 ¹	1057235	MH 10	NA	MH 50	NA
RF 3101 ¹	1057243	MH 13	1057164	MH 53	NA
TP 201	1057299	MH 16	1057179	MH 56	NA
TP 4	1057290	MH 19	1057175	MH 12A	1057183
TP 5	1057287	MH 22	1057170	MH 15	1057180
TP 601	1057293	MH 25	1057162	MH 18	1057176
TP 9	1057276	MH 28	1057158	MH 21	1057171
Note 1: Manhole has multiple asset numbers.					

YOSEMITE NATIONAL PARK UTILITIES BRANCH

SEWER SYSTEM MANAGEMENT PLAN

EL PORTAL

SANITARY SEWER SYSTEM (CS 5SSO10735)

TABLE 4.1 (Continued)
EI Portal Manhole and Cleanout Inspection Schedule (2014)

Manhole or Cleanout Location	Asset Number	Manhole or Cleanout Location	Asset Number	Manhole or Cleanout Location	Asset Number
TP 12	1057273	MH37	1057149		
MH 24	1057167	MH 42	NA	MH 54	NA
MH 27	1057159	MH 45	NA	MH 57	NA
MH 36	1057150	MH 48	NA		
MH 39	1057147	MH 51	NA		
Note 1: Manhole has multiple asset numbers.					

TABLE 4.1 (Continued)
EI Portal Manhole and Cleanout Inspection Schedule (2015)

Manhole or Cleanout Location	Asset Number	Manhole or Cleanout Location	Asset Number	Manhole or Cleanout Location	Asset Number
RF 3	1055256	RF 705	1057102	EP 1605	1055233
RF 16	1055251	RF 703	1057030	EP 26	1055240
RF 17	1055252	RF 706	1055261	EP 32	1057307
RF 19	NA	RF 23	1055254	EP 1603	1057123
RF 303	1055257	RF 30	1057236	EP 1606	1055235
RF 304	1057200	RF 34	1055259	EP 19	1055237
RF 402	1055260	EP 602 ¹	1057125	EP 30	1057309
RF 702	1057029	EP 602 ¹	1057327	EP 31	1057308

YOSEMITE NATIONAL PARK UTILITIES BRANCH

SEWER SYSTEM MANAGEMENT PLAN

EL PORTAL

SANITARY SEWER SYSTEM (CS 5SSO10735)

TABLE 4.1 (Continued)
EI Portal Manhole and Cleanout Inspection Schedule (2016)

Manhole or Cleanout Location	Asset Number	Manhole or Cleanout Location	Asset Number	Manhole or Cleanout Location	Asset Number
RF 1	1056805	RF 301	1057198	RF 503	1057188
RF 401 ¹	1056790	RF 502	1057187	RF 505A	1057196
RF 401 ¹	1057197	RF 505	1057190	RF 7	1056782
RF 501	1057185	RF 6	1056784	RF 709	1057061
RF 504	1057189	RF 708	1057058	RF 9	NA
RF 506	1057192	RF 8	1056780	RF 11	1056773
RF 701	1057028	RF 10	NA	RF 13	1056769
RF 704	1057100	RF 2401	1057251	RF 15	1057231
RF 401 ¹	1056790	RF 2	1056803	RF 18	NA
RF 12	1056772	RF 302	1057199	RF 2402	1057259
RF 1801 ¹	1057229	RF 4	NA	RF 2403	1057260
RF 1801 ¹	1057232	RF 5	1056785	RF 27	1057237
RF 24	1057240				
EP 1	1057076	RF 3001	1057248	EP 22 (EP 20B)	1057311
EP 4	1057068	RF 32	1057234	EP 24 ¹	1057117
EP 8	1057325	RF 34A	1057233	EP 24 ¹	1057115
EP 11	1057322	EP 6	1057326	EP 3003	1057082
EP 14	1057319	EP 7	1057326	EP 33	1057306
EP 16	1057317	EP 10	1057323	MH 31A	NA
EP 1602	1057121	EP 13	1057320	MH 33	NA
RF 25	1057239	EP 15	1057318	EP 17	1055236
EP2	1057073	EP 1601	NA	EP 20	1057313
EP 3	1057069	EP 18	1057315	EP 3001	1057077
EP 5	1067067	EP21 (EP20A)	1057312	EP 34	1057305
EP 9	1057324	EP 23A	1055239	EP 46	1057128

Note 1: Manhole has multiple asset numbers.

YOSEMITE NATIONAL PARK UTILITIES BRANCH

SEWER SYSTEM MANAGEMENT PLAN

EL PORTAL

SANITARY SEWER SYSTEM (CS 5SSO10735)

TABLE 4.1 (Continued)
EI Portal Manhole and Cleanout Inspection Schedule (2016)

Manhole or Cleanout Location	Asset Number	Manhole or Cleanout Location	Asset Number	Manhole or Cleanout Location	Asset Number
EP 12	1057321	EP 29	1057310	EP 4801	NA
EP 1401	1057124	EP 3002	1057079	EP 50A	NA
EP 16A	1057316	EP 44	1057136	MH 30	1057155
RF 26	1057238	EP 49	1055245	MH 31 B	NA
RF 28	NA	MH 31	1057153	MH 35	1057151

Note 1: Manhole has multiple asset numbers.

All visual manhole inspections are anticipated to be completed from the surface; however, all manhole inspections should consider health and safety concerns. **Therefore, all workers must be trained in confined space entry to include gas detection, ventilation assessment, and proper use of egress equipment for safe manhole entry/exit.**

2. Internal Pipe Inspection – CCTV

Various technologies can be used to internally survey and inspect pipe integrity that include the use of camera, acoustical, electro-magnetic, laser, and other technologies; but the camera using closed circuit television (CCTV) is most commonly used because of its simplicity, costs, and visual data generated.

The primary purpose of CCTV inspection is to identify breaks, root intrusion, leaking water (especially infiltration from groundwater), and general deteriorating conditions within the sewer main that may result in SSO's. This information will be used in the condition assessment of the sewer collection system and direct the prioritization and scheduling of repair and rehabilitation projects, as discussed below.

The National Association of Sewer Service Companies (NASSCO) developed the Pipeline Assessment Certification Program (PACP) for reporting, grading, and prioritizing potential system defects that lead to sewer cleaning and/or system repairs based on CCTV results. Defect Codes established by the PACP program

YOSEMITE NATIONAL PARK UTILITIES BRANCH

SEWER SYSTEM MANAGEMENT PLAN

EL PORTAL

SANITARY SEWER SYSTEM (CS 5SSO10735)

classify defects by category, defect type, and severity. This defect grading system helps determine and consistently document the overall physical condition of pipe segments and the priority for further inspections and/or maintenance. Section 5, Specification Section – 5.3 includes the description of the defect codes, defect terms, and defect grading requirements for CCTV inspection results along with the PACP defect grading system that uses a scale of 1 to 5, with 1 representing a minimal defect and 5 representing the worst defect.

The Rancheria Flat and Old El Portal sewer collection systems were extensively CCTV inspected beginning in October 2009. Numerous piping irregularities were noted during the 2009 CCTV inspection that may potentially lead to SSOs, refer to Section 4.4 for more details. For example, approximately 6 SSO events have been noted in the Rancheria Flat and Old El Portal during the past five years.

The NPS plans to proactively CCTV inspect each sewer pipe segment at least once every 15 years. Therefore, the next scheduled CCTV inspection of the El Portal sewer collection system shall be completed by 2024. Future CCTV results should be reported in the format presented in Exhibit 4.3.

3. Routine Sanitary Sewer Cleaning

The purpose of routine sewer cleaning is to prevent blockages that occur within the sewer main and/or its laterals that may result in SSO's.

The 2009 CCTV inspection results for Rancheria Flat and Old El Portal sewer systems identified segments of the collection system that were evaluated with a severity or defect rating of 3 or greater. The deficiency of these segments is associated with surface corrosion, deposited encrustation, root intrusion, joint separation, and alignment deviation resulting in standing water within the pipeline. These moderately to severely defective areas that showed signs of debris accumulation and/or standing water were selected for more frequent cleaning. These pipeline segments and associated segments are noted in Figures 4.3 through 4.9. These defective areas should be cleaned again in 5 years as shown in Table 4.2, unless other data indicates more frequent sewer cleaning is necessary.

YOSEMITE NATIONAL PARK UTILITIES BRANCH

SEWER SYSTEM MANAGEMENT PLAN EL PORTAL SANITARY SEWER SYSTEM (CS 5SSO10735)

TABLE 4.2
Rancheria Flat Routine Sanitary Sewer Cleaning Schedule

Pipe Segment	Asset Number	Next Year of Cleaning
RF 4:RF 5	1055135	2017
RF 503:RF 502	1055718	2017
RF 501:RF 5	1055704	2017
RF 5:RF 6	1055137	2017
RF 708:RF 706	1055697	2017
RF 703:RF 702	1055696	2017
RF 701:RF 7	1055695	2017
RF 15:RF 16	1055622	2017
RF 24:RF 25	1055594	2017
RF 27:RF 28	1055596	2017
RF 30:RF 31	1055597	2017
CO 860:RF 505A	unknown	2017
RF 502:RF 501	1055716	2017
CO 871:RF 5	unknown	2017
RF 709:RF 708	unknown	2017
RF 706:RF 702	1055180	2017
RF 702:RF 701	1055174	2017
RF 8:RF 9	1055169	2017
RF 23:RF 24	1055698	2017
RF 25:RF 26	1055699	2017
RF 29:RF 30	1055181	2017
RF 34A:RF 34	1055598	2017

NOTE – Cleaning to be repeated every 5 years.

YOSEMITE NATIONAL PARK UTILITIES BRANCH

SEWER SYSTEM MANAGEMENT PLAN EL PORTAL SANITARY SEWER SYSTEM (CS 5SSO10735)

TABLE 4.2 (Continued)
Old El Portal Routine Sanitary Sewer Cleaning Schedule

Pipeline Segment	Asset Number	Next Year of Cleaning
EP 24;EP 25	1056231	2017
EP 26;EP 21 (EP20A)	1056233	2017
EP 22 (EP 20B);EP 23	1056176	2017
EP 23;EP 29	1056168	2017
EP 30;EP 31	1056169	2017
EP 32;EP 33	1056234	2017
EP34;EP 35	1056158	2017
EP 44;EP 42	1056170	2017
EP 24;EP 25	1056231	2017
EP 25;EP 26	1056232	2017
EP 21 (EP20A);EP 22 (EP20B)	1056230	2017
EP 23 C;EP 23	unknown	2017
EP 29;EP 30	1056178	2017
EP 31;EP 32	1055132	2017
EP 33;EP 34	1056236	2017
EP 43;EP 44	1056248	2017
EP 4801;EP 48	1056152	2017

NOTE – Cleaning to be repeated every 5 years.

YOSEMITE NATIONAL PARK UTILITIES BRANCH

SEWER SYSTEM MANAGEMENT PLAN

EL PORTAL

SANITARY SEWER SYSTEM (CS 5SSO10735)

NPS plans to clean the pipe segments shown in Table 4.2 at least once every 5 years and the remainder of the collection system may be cleaned in 15 years (2027), pending the CCTV results collected in 15 years. However, as the NPS begins to collect and analyze maintenance data collected during proactive and preventive cleaning the frequency of sewer cleaning will be adjusted to optimize performance, as shown in Diagram 4.1. For example, cleaning and jetting may also further degrade the condition of the older cracked VCP piping that is scheduled for rehabilitation.

The NPS has the capacity to perform emergency and preventative sewer cleaning, but may contract sewer cleaning activities. If NPS selects contracting sewer cleaning, the entire sewer collection system should be scheduled through one contract period because of the contracting complexities and limited size of the El Portal sewer system.

Table 4.3 describes the USRO planning and scheduling steps for sewer cleaning events. USRO staff or contractor will be required to record sewer cleaning results for each manhole-to-manhole pipe segment using the code-based terms presented in Exhibit 4.3 and document the sewer pipe cleaning event using Exhibit 4.3; whereas the results then provide the basis for modifying the frequency or method of sewer cleaning for a pipe segment. Follow-up CCTV inspections and/or repairs will be requested as needed by the USRO. This process is shown on Diagram 4.1.

NASSCO specifications for CCTV inspections and sewer cleaning are presented in Section 5, Specification Section - 5.3 for potential contractor procurement.

YOSEMITE NATIONAL PARK UTILITIES BRANCH

SEWER SYSTEM MANAGEMENT PLAN

EL PORTAL

SANITARY SEWER SYSTEM (CS 5SSO10735)

TABLE 4.3
Summary of USRO Steps Required for Typical Sewer Cleaning Events

Steps	Description of Sewer Cleaning Activity
1	FMSS Help Desk issues work order requesting the sewer maintenance or cleaning activity which describes the activity location, line segment, manhole numbers, and other pertinent site information.
2	USRO supervisor designates or assigns USRO service team (minimum 2 persons) that are properly trained and equipped for sewer cleaning activities.
3	USRO service team <u>plans</u> sewer cleaning event: <ol style="list-style-type: none">Obtain mapping and verify pipe sizes. (Figures 4.2 through 4.9 may be used.)Inventory and inspect hardware, traffic control, and safety equipment for safe operability.Inspect high pressure/velocity cleaner and vacuum truck and pre-fill water tank.Perform daily equipment maintenance requirements or checks per the operator's manual just prior to departing the equipment storage and maintenance yard. Pre-inspect designated manhole interiors to ensure manholes do not require pre-cleaning or washing manhole interiors prior to access. Clean or wash manholes as necessary. (This step can be performed during the execution step, but additional safety wear may be required for wet, slippery, dripping manhole interiors.)
4	USRO service team <u>implements</u> sewer cleaning event and documents per the sewer cleaning report: <ol style="list-style-type: none">Stage all equipment at the site in a safe orderly manner to minimize traffic disturbance. Utilize additional traffic controls such as lighted barricades as necessary.Locate and safely open manholes.<u>Follow confined space entry requirements as defined by NPS/YOSE safety policy, qualified training, supervisor direction and specific site conditions.</u><u>Continually exercise precautions regarding traffic safety and confined space entry.</u> Select the proper cleaning or cleaning tool for the debris to be removed and pipe size to be cleaned.Position and set up sewer cleaning equipment and/or vehicle at the operating manhole in accordance with the Operator's Manual. All sanitary sewer line segments should be cleaned from upstream manhole to the downstream manhole, whenever possible. Vacuum truck should be set up at the downstream manhole to vacuum silts, debris, and other solids and to prevent solids flow to the wastewater treatment facility.Remove debris from the operating manhole (using a rake or screen as necessary). Cleaned sewers should be free of grease, sludge, debris, roots and other obstructions to provide an unobstructed sewer flow.

YOSEMITE NATIONAL PARK UTILITIES BRANCH

SEWER SYSTEM MANAGEMENT PLAN EL PORTAL SANITARY SEWER SYSTEM (CS 5SSO10735)

TABLE 4.3 (Continued)
Summary of USRO Steps Required for Typical Sewer Cleaning Events

Steps	Description of Sewer Cleaning Activity
	<ul style="list-style-type: none">vii. Operate the sewer cleaning equipment in accordance with the Operator's Manual. For example, the equipment is never operated in excess of its rated capacity (speed, pressure, etc.). Exceeding or abusing the equipment's intended use can result in failure of equipment, damage to pipes, personal injury, and subsequent work delay. Operate and maneuver the high velocity nozzle as described in the Operator's Manual. A hydraulic water pressure root-cutter should be used in sections suspected of and documented as having heavy root and grease problems.viii. Operate the vacuum truck and its appurtenances in accordance with the Operator's Manual.ix. Notify the USRO supervisor if the sewer piping cannot be cleaned with the hydraulic cleaning equipment to determine subsequent action(s).
5	<p>USRO service team <u>completes</u> sewer cleaning event.</p> <ul style="list-style-type: none">i. Perform site cleanup. Remove and properly dispose of all wastes generated from sewer cleaning activity. Ensure manholes are secured and all hardware, traffic control, and safety equipment are accounted for and secured.ii. Report status of sewer cleaning activity to FMSS Help Desk and USRO Supervisor. Secure and stage all equipment at Yosemite Valley maintenance yard.

4.3.3 LIFT STATION CLEANING AND INSPECTION SCHEDULE

El Portal and its developed areas have seven lift stations:

- One large and one small lift station in the Maintenance Complex area.
[The submittal of asset numbers by the park for these lift stations is pending.]
- One large lift station in Abbyville serving the Trailer Court/Park area with asset no. 31037.
- Four small lift stations in the Old El Portal area that includes:
 - i. Lift station serving the Motor Inn, asset no. 1019374
 - ii. Lift station serving the El Portal Market, asset no. 31035.
 - iii. Lift station serving the Resource Management & Science, asset no. 31038.
 - iv. Lift station serving the petroleum bulk plant, asset no. 1090747.

YOSEMITE NATIONAL PARK UTILITIES BRANCH

SEWER SYSTEM MANAGEMENT PLAN

EL PORTAL

SANITARY SEWER SYSTEM (CS 5SSO10735)

Both large lift stations have 15 hp or greater pumps with diesel powered generators for backup emergency power.

The USRO staff performs daily, weekly, quarterly, and annual inspections for each lift station. NPS's pump or lift station maintenance program is based primarily on following the manufacturer's recommendations for pump station maintenance.

NPS has planned periodic inspections to ensure the pump stations are being operated in accordance to the manufacturer's recommendations and specific conditions that the USRO staff has developed based on their past observations and experience of pump station operation. The inspections for the seven lift stations described above include the following minimum elements:

Daily / Weekly Inspections

1. The outer housing of the lift station should be visually inspected daily for SSOs.
2. Visually inspect the station for vandalism.
3. Visually inspect all pumps, looking for signs of leaks around valves and piping that might indicate wear, failure, excessive vibration, or abnormal sounds.
4. Remove and properly dispose of any trash or debris material.
5. Inspect the valve positions. The suction and discharge valves should be positioned for completely open and the bleeder valves should be closed.
6. Record pump hours for each pump. Hour meters should be installed onto all pumps for an accurate record of motor cycling and to determine the volume of water pumped through the system during the designated period. Additional hour meter readings will help evaluate the sewer's hydraulic capacity if sewer flow measurements discussed in Section 8 are correlated to hour meter readings. Furthermore, it is recommended that lead pumps alternate at least weekly.
7. Record the amount of pump flow meter readings, if available
8. Run each pump by hand / manual control and observe water levels in wet well to ensure pumps are operating properly.

YOSEMITE NATIONAL PARK UTILITIES BRANCH

SEWER SYSTEM MANAGEMENT PLAN

EL PORTAL

SANITARY SEWER SYSTEM (CS 5SSO10735)

9. Note any unusual or excessive vibrations that might indicate a pump or motor balance problem.
10. Wash down wet well.
11. Inspect and test the visual and telemetry alarm systems to ensure proper operation.
12. For pumps having emergency generators:
 - i. Check propane fuel level in both tanks.
 - ii. Check engine oil levels.
 - iii. Check water coolant levels.
 - iv. Check battery electrolyte level.
 - v. Check power ready mode.

Monthly Inspections

1. Visually inspect the station for vandalism.
2. Check and ensure room exhaust fans are operational, if applicable.
3. Ensure all safety guards are in place.
4. Check condition and availability of personal safety equipment.
5. Exercise the isolation valves.
6. Pump the wet well to its lowest level and make a visual inspection of the wet well and the pumping of each pump. Wash the wet well during the pump down process.
7. Inspect wet well for excessive grease build up on surface and clean as necessary.
8. Clean and inspect float controls or pressure sensors of any grease buildup or rags that would prevent the floats or sensors from working properly.
9. Visually check pumps and piping for defects or damages.
10. Measure and record motor amperage readings for each pump motor. If the readings do not meet the manufacturer's specifications, it is an indication that debris is lodged in the propeller within the motor, or that water has entered the motor housing or wiring, or the pump has experienced excessive wear.

YOSEMITE NATIONAL PARK UTILITIES BRANCH

SEWER SYSTEM MANAGEMENT PLAN

EL PORTAL

SANITARY SEWER SYSTEM (CS 5SSO10735)

11. Check emergency generator and manually start, if applicable.
 - i. Check propane fuel levels in both tanks.
 - ii. Check engine oil levels.
 - iii. Check water coolant levels.
 - iv. Check battery electrolyte levels.
 - v. Check power ready mode.

Quarterly Inspections

1. Inspection of pumps should be performed quarterly or when motor hours are not within ten percent of each other. Inspections are intended to assure that impellers are free of debris.
2. Generators are to be operated under load, for 15 minutes. This test is to be conducted by tripping power to the lift station and observing a successful transfer to generator power. Emergency generators are to be operated per manufacturer's requirements and in compliance with any City, County, or State agency operating permit. Check emergency generator for:
 - i. Check propane fuel level in both tanks.
 - ii. Engine oil level.
 - iii. Water coolant level.
 - iv. Battery electrolyte level.
 - v. Check power ready mode.

Semi-Annual Inspection

1. Wet wells will be pumped out and cleaned at least twice per year, or more often if necessary, to prevent solids and grease build-up. Build-up of solids can create odors and damage to the pump.
2. Check valves should be inspected at least twice per year, to ensure the valves are properly functioning for preventing backflow from the force main to the wet well.

YOSEMITE NATIONAL PARK UTILITIES BRANCH

SEWER SYSTEM MANAGEMENT PLAN

EL PORTAL

SANITARY SEWER SYSTEM (CS 5SSO10735)

3. Measure total dynamic suction head and discharge head as a test. This is especially important where the fluid being pumped tends to form a deposit on internal surfaces.

Annual Inspection

1. The pumps should be removed annually and inspected in accordance with pump manufacturer's O&M manual. Remove the rotating element and inspect it thoroughly for wear. Order replacement parts as necessary. Check pump wearing clearances. Remove any deposits or scaling.

4.3.4 FORCE MAIN CLEANING AND INSPECTION SCHEDULE

El Portal has seven force mains. Two force mains are located in the Maintenance Complex, one is located in the Trailer Court/Park, and the remaining four are located in Old El Portal as discussed in section 4.3.2. The force mains and its backfilled trench should be inspected daily for SSOs and signs of piping failure. Regularly scheduled force main cleaning is not anticipated; however, debris, greases or other matter may accumulate on the piping interior walls and affect pipe capacity. Pump stations should have calibration checks annually by observing and comparing pump pressures and flow meter readings to determine if any changes in pipe capacity and discharge head can be identified (e.g., cleaning is required when pump discharge pressures are 25% greater than noted during earlier clean pipe conditions.) Because these changes could also be attributed to pump wear, it is essential to verify that the pumps are in good working order before determining that the force main needs cleaning.

If it is determined that the pressure sewer mains require cleaning, the cleaning of the pressure sewer main will be scheduled at that time. The most common method of cleaning force mains is by use of polyurethane swabs, which are commonly known as "poly pigs." Poly pigs are available in various densities and surface coatings. To use this method, poly pigs are inserted into the pipeline, which is then pressurized behind the pig. As the device travels through the force main it scours the inside of the pipe. It is anticipated that NPS will contract the pressure sewer cleaning by the use of "poly pigs" or another method determined to be more appropriate at the time.

Isolation valves on the pressure sewer mains should be exercised annually.

YOSEMITE NATIONAL PARK UTILITIES BRANCH

SEWER SYSTEM MANAGEMENT PLAN

EL PORTAL

SANITARY SEWER SYSTEM (CS 5SSO10735)

4.3.5 OIL / WATER SEPARATOR CLEANING AND INSPECTION SCHEDULE

The Maintenance Complex for El Portal has one oil/water separator (Asset No. _____) located in building 759 to remove fuels, lubricants, and solids found in equipment wash water. The treated wash water is then piped to a lift station where it is pumped to the EL Portal wastewater treatment facility for treatment. The ability of oil/water separators to function properly depends upon the timely performance of required service and maintenance; therefore, USRO staff should visually inspect the area housing the oil/water separator during and immediately following maintenance activities and equipment washing for SSOs. Thereafter, the oil/water separator should be visually inspected weekly for accumulated petroleum products and floating matter to ensure the oil/water separator is functioning properly and discharging to the sewer system with no apparent signs of sewer backup. Quarterly inspections should be made of the oil/water separator system and its associated piping, valves, etc. to prevent operational and mechanical failures or inefficiencies. Additionally, sludge depths should be determined at least during the spring and fall months and more frequently during heavy equipment maintenance activities. Sludge shall be removed/vacuumed when sludge depths exceed 12 inches, or exceed 20% tank volume, or every five years, whichever is more frequent. However, sludges must be first characterized by analytical testing before the sludge is pumped or vacuumed from the vault for final disposal. Analytical testing is used to determine the final regulatory disposition of the sludges and to confirm the sludges are not hazardous wastes. Analytical testing may require testing for total petroleum hydrocarbons, toxicity characteristic leaching procedure (TCLP) tests for the 8 common heavy metals, TCLP tests for semi volatile petroleum contaminants, and/or TCLP tests for chlorinated hydrocarbon contaminants as specified in the US Environmental Protection Agency's (EPA) Resource Conservation and Recovery Act (RCRA). Refer to RCRA waste characterization procedures stipulated in 40 CFR Part 261.

Sludges found to be hazardous wastes must be disposed of as hazardous wastes and the site maintenance activities further evaluated to determine what maintenance activity (ies) created the sludge with hazardous waste characteristics. The USRO supervisor shall review the analytical data and determine whether the sludge requires special handling and/or disposal. The vaults shall be washed with a pressure washer immediately following sludge removal and the vault decontaminated if hazardous wastes are found.

YOSEMITE NATIONAL PARK UTILITIES BRANCH

SEWER SYSTEM MANAGEMENT PLAN

EL PORTAL

SANITARY SEWER SYSTEM (CS 5SSO10735)

Additionally, the vaults should be leak tested every ten years to ensure petroleum hydrocarbons are not leaking into the surrounding soils. Furthermore, an oil/water separator designed and installed to meet a specific equipment maintenance activity may not be suitable for other equipment maintenance issues that may result in more wash water use and/or a change in physical/chemical makeup of the wastewater. Therefore, USRO staff should inform the Design and Engineering Branch of any procedural changes in equipment maintenance to ensure the existing oil/water separator is properly sized and designed to accommodate the change in maintenance procedures.

4.3.6 SEWER SYSTEM EQUIPMENT AND REPLACEMENT PARTS INVENTORY

Standby or emergency response equipment for El Portal includes the following which are staged at the Maintenance Complex:

- Various types and sizes of piping, valving, and appurtenances.
- Small portable generators to provide emergency power to any of the five small lift stations (<5 hp) within El Portal.
- Front-end loader backhoe, small pumper truck, vacuum truck, and sewer flusher truck.

Additionally, a large portable generator is staged at the Trailer Park's large lift station for emergency power. Other equipment such as an excavator may be obtained from the Yosemite Valley maintenance yard or rented from United Rentals, 1346 West 16th Street, Merced, California (209.383.2984) who has typically delivered equipment rentals within 4 hours.

YOSEMITE NATIONAL PARK UTILITIES BRANCH

SEWER SYSTEM MANAGEMENT PLAN

EL PORTAL

SANITARY SEWER SYSTEM (CS 5SSO10735)

4.3.7 TRAINING REQUIREMENTS

California Waste Discharge Requirements Order R5-2008-0060 requires the management, operation, and maintenance of all parts of the sanitary sewer system be performed with system operators (including employees, contractors, or other agents) that are adequately trained and possess adequate knowledge, skills, and abilities.

The federal National Pollutant Discharge Elimination System NPDES permit program stipulates the wastewater collection system is part of the wastewater collection, treatment, and disposal system that must be properly operated and maintained. However, SWRCB Order No. 2006-0003 contains additional requirements for proper operation and maintenance of collection systems as well as the reporting and mitigating SSOs. Therefore trained and experienced personnel is a regulatory requirement for proper wastewater collection system operation.

The NPS participates in the California Water Environment Association (CWEA), whereas the CWEA, through the Technical Certification Program (TCP) develops and administers competency tests for personnel operating and maintaining wastewater collection and treatment systems. Though certifications are not yet mandatory for state compliance, the certifications demonstrate personnel qualifications; therefore, NPS encourages its USRO staff to obtain CEWA certification. The USRO staff should strive to maintain at least one Collection Systems Maintenance Grade II (CSM II) certification with at least one worker having at least Grade I (CSM I) certification. However, given the relatively complex sewer system components for El Portal with seven lift stations, USRO staff should be encouraged to obtain the next higher certification grade.

The NPS also provides on-going in-house technical, job skills, and safety training for its staff as well as participates in local and regional training opportunities to include sewer line cleaning, sewer grit removal and disposal, valve and piping repair/replacement and other O&M activities. Additionally, NPS complies with the Waste Discharge Requirements (WDR) permitting program that requires sewer system overflow (SSO) response training. Table 4.4 describes a typical worker development and training program for NPS wastewater collections staff, also known as the Individual Training Program (ITP) for USRO Staff.

YOSEMITE NATIONAL PARK UTILITIES BRANCH

SEWER SYSTEM MANAGEMENT PLAN

EL PORTAL

SANITARY SEWER SYSTEM (CS 5SSO10735)

TABLE 4.4
Individual Development Plan (IDP) for USRO Staff

Employer's Name:	Position Title/Grade:	Office Phone:	Office Fax:	Email Address:
	USRO WG 5/7/9			
Supervisor's Name:	Supervisor's Title:	Office Phone:	Office Fax:	Email Address:
Goals for successful performance in SCEP position: Demonstrate competent performance in the following		Short Term Goals (2-3 years)		Long Term Goals (3+ years)
Water Treatment Operations Water Distribution Systems Backflow Prevention Small Waste Water Treatment Systems Waste Water Collection Systems		Grade 1 Water Treatment License Grade 1 Water Distribution License Complete CSUS Program		Grade 2 Water Treatment License Backflow Tester Certificate Complete CSUS Program

Developmental Objective/Competencies: What do you need to do each year to work towards your goals/what NPS Competencies do these goals address?	Developmental Activities (training, assignments, projects, details, etc.)	Proposed dates (add actual dates after EOD is established)	Estimated Costs:	Date Completed:
Year 1 Obtain a comprehensive understanding of the Utilities Branch.	Year 1 1200 hour minimum assignment in Valley Utilities 160 hour assignment in WA Util 160 hour assignment in EP Util 160 hour assignment in HV Ops 80 hour assignment in BCU			
Obtain necessary Knowledges, Skills, and Abilities to perform as a Journey Level Mechanic/USRO in Utilities Branch.	Complete CSUS Program Small Water System O&M Complete CSUS Program Water Distribution System O&M	Within 6 months of EOD Within 12 months of EOD	Enrollment 50 Manual 49=\$100 Enrollment 50 Manual 49=\$100	

2/1/2012

YOSEMITE NATIONAL PARK UTILITIES BRANCH

SEWER SYSTEM MANAGEMENT PLAN

EL PORTAL

SANITARY SEWER SYSTEM (CS 5SSO10735)

TABLE 4.4 (Continued)
Individual Development Plan (IDP) for USRO Staff

Year 1 Obtain necessary licenses to perform duties of the position.	Year 1 Obtain Grade 1 Water Treatment License Obtain Grade 1 Water Distribution License	Within 12 months of EOD	\$100	
If all requirements for Year 1 are met and satisfactory performance and conduct are achieved for the year, promotion to the WG 7 level will be approved.				
Developmental Objective/Competencies: What do you need to do each year to work towards your goals/what NPS Competencies do these goals address?	Developmental Activities (training, assignments, projects, details, etc.)	Proposed dates	Estimated Costs:	Date Completed:
Year 2 Obtain a wide understanding of the Utilities Branch.	Year 2 1200 hour minimum assignment in Vly Utl 160 hour assignment in WA Utl 160 hour assignment in EP Utl 160 hour assignment in HV Ops 80 hour assignment in BCU			
Obtain necessary Knowledges, Skills, and Abilities to perform as a Journey Level Mechanic/USRO in Utilities Branch.	Complete CSUS Program Small Waste Water System O&M Vol. 1 Complete CSUS Program Small Waste Water System O&M Vol. 2	Within 18 months of EOD	Enrollment 50 Manual 49=\$100	
Obtain necessary licenses to perform duties of the position.	Obtain Grade 2 Water Treatment License	Within 24 months of EOD	\$100	

2/1/2012

YOSEMITE NATIONAL PARK UTILITIES BRANCH

SEWER SYSTEM MANAGEMENT PLAN

EL PORTAL

SANITARY SEWER SYSTEM (CS 5SSO10735)

TABLE 4.4 (Continued)
Individual Development Plan (IDP) for USRO Staff

Developmental Objective/Competencies: What do you need to do each year to work towards your goals/what NPS Competencies do these goals address?	Developmental Activities (training, assignments, projects, details, etc.)	Proposed dates	Estimated Costs:	Date Completed:
Year 3 Obtain a wide understanding of the Utilities Branch.	Year 3 1200 hour minimum assignment in Vly Utl 160 hour assignment in WA Utl 160 hour assignment in EP Utl 160 hour assignment in HV Ops 80 hour assignment in BCU			
Obtain necessary Knowledges, Skills, and Abilities to perform as a Journey Level Mechanic/USRO in Utilities Branch.	Complete CSUS Program O&M of Waste Water Collection Systems Vol. 1	Within 30 months of EOD	Enrollment 50 Manual 49=\$100	\$100
	Complete CSUS Program O&M of Waste Water Collection Systems Vol. 2	Within 36 months of EOD	Enrollment 50 Manual 49=\$100	\$100
	Backflow Tester Training Vendor TBD	Within 30 months of EOD		
Obtain necessary licenses to perform duties of the position.	Obtain Backflow Tester Certification	Within 36 months of EOD		\$500
	Obtain Collection System License if required in the future	Within 12 months of new requirement		\$100
<p>If all requirements for year 2 and 3 are met and satisfactory performance and conduct are achieved for the previous 2 years, promotion to the WG 9 level will be approved. Employee may be non-competitively converted to a Term or Permanent vacant USRO WG-4742-9 or equivalent career appointment within 120 days. If no vacancy exists YOSE will provide placement assistance. Course costs and license fees to be paid by agency by reimbursement with paid receipts and proof of passing grade in the course. Enrollee will be allowed 8 hours per week on the job time to study – time to be negotiated between Student and Supervisor. Allowances will be made for travel time to temporary assignments with GOV and on Government time. Notes: CSUS references are to the Operator Training correspondence program at Sacramento, each manual/enrollment is 9 CEUs. Office of Water Programs, California State University Sacramento, 6000 J Street, Sacramento, CA 95819-6025 www.owp.csus.edu</p>				
Employee's Signature and Date				
Supervisor's Signature and Date				2/1/2012

YOSEMITE NATIONAL PARK UTILITIES BRANCH

SEWER SYSTEM MANAGEMENT PLAN

EL PORTAL

SANITARY SEWER SYSTEM (CS 5SSO10735)

4.4 REHABILITATION AND REPLACEMENT PLAN

Sewer system rehabilitation and repairs following sewer system inspections and assessments is an integral part of the preventative maintenance program. SWRCB Order 2006-0003 requires the rehabilitation and replacement plan to identify and prioritize sewer system deficiencies for the design and implementation of short-term and long-term sewer rehabilitation measures to prevent SSOs. Rehabilitation and replacement measures (hereafter referred to as R&R) focus on 1) sewer components that are at risk of failure due to collapse or breakage; 2) sewer pipes prone to more frequent blockages due to pipe alignment or defects; and 3) sewer components not adequately sized or designed to accommodate existing sewer capacity requirements wherein there is high potential for SSOs. Initially, R&R projects are the result of observed deficiencies in the sanitary sewer system; however, the collection of pump station performance data and sewer flow data as directed in Section 4.3 and Section 8 is expected to better identify and clarify the R&R projects necessary to control SSOs. The sewer systems serving El Portal and its developed area have experienced seven SSOs associated with untreated wastewater and one SSO associated with treated reuse wastewater during the past five years. The SSO areas are mapped in Figures 4.3 through 4.9.

4.4.1 SEWER CONDITION INSPECTION AND ASSESSMENT

The sewer condition assessment of El Portal and its developed areas which included the Maintenance Complex, Rancheria Flat, Trailer Park, Old El Portal, and the Yosemite View Lodge resort is made based on the CCTV inspection results conducted in 2009. Except the Maintenance Complex was not CCTV inspected in 2009 and CCTV data is not available for the Trailer Park. The assessment ranked the condition of the sewer lines into priority groups in accordance with PACP guidelines as discussed in Section 4.3; therefore, sewer condition assessment summaries or summary and priority of pipe segment repairs are provided in tabular format in Tables 4.5 through 4.8 showing the condition assessments for Rancheria Flat, Trailer Park, Old El Portal, and the 16 inch diameter sewer main from Yosemite View Lodge resort to the El Portal wastewater treatment facility, respectively.

**TABLE 4.5
Summary and Priority of Pipe Segment Repairs for Rancheria Flat**

PACP Pipeline Assessment Certification Program Priority Group	Upstream MH or Cleanout	Downstream MH or Cleanout	YOSE Inventory Asset Number	Pipe Diameter (inches)	Length (ft)	Material	Problem Summary	Maintenance	SSO's/Date
4	RF101	RF1	1055133	6	304.5	VCP	Multiple crack, large joint offset, fracture, deposits, roots.		
4	RF303	RF302	1055148	6	43.8	VCP	[Multiple breaks, hole open to soil, fine root at joint].	Root Cutting 11/5/2009	
4	RF302	RF301	1055150	6	79.3	VCP	[broken 7 to 10 oclock, multiple crack 12 to 12 oclock, fine roots at joints].	Root Cutting 11/5/2009	
4	RF402	RF401	1055172	6	260.5	VCP	[Multiple crack, Break from 2 to 5 oclock, root ball barrel, camera stopped on rootball].	Root Cutting 11/5/2009	
4	RF4	RF5	1055135	6	126.8	VCP	[medium and fine roots at joint] [crack longitudinal, fine and medium roots at joints, camera stopped on roots line inspection from MH to MH INCOMPLETE].		
4	RF5	RF6	1055137	6	297.5	VCP	multiple circumferential crack, multiple fine and medium roots at joints.		
4	RF707	RF706	1055138	6	199.6	VCP	longitudinal fracture, fine deposits 5%csa, water mark 5%csa.		
4	RF706	RF702	1055180	6	199.6	VCP	[medium roots on joints, broken soil].	Root Cutting 11/5/2009	
4	RF702	RF701	1055174	6	60.1	VCP	[medium and fine roots at joints, Joint offset large, camera stopped on offset].	Root Cutting 11/5/2009	
4	RF8	RF9	1055169	6	189.9	VCP	multiple breaks - soil exposed, medium and fine roots at joints, medium roots along barrel.		
4	RF29	RF30	1055181	6	70.4	VCP	[fine roots on joints, joint offset large and medium].	Root Cutting 11/6/2009	
4	(RF30)	(RF32)	?				joint offset large] [tap break intrusion, medium and fine roots on joints, multiple joint offset large, camera stopped on offset joint].		
3	RF1	RF2	1055629	6	78.7	DIP	medium joint offset , deposits fine 5%csa.		
3	RF304	RF303	1055641	6	68.2	VCP	[medium roots at joints, camera stopped on roots] [fine and medium roots at joints, camera stopped on roots].		
3	RF301	RF3	1055703	6	109.0	VCP	[fine roots at joints].	Root Cutting 11/5/2009	

TABLE 4.5 (Continued)
Summary and Priority of Pipe Segment Repairs for Rancheria Flat

PACP Pipeline Assessment Certification Program Priority Group	Upstream MH or Cleanout	Downstream MH or Cleanout	YOSE Inventory Asset Number	Pipe Diameter (inches)	Length (ft)	Material	Problem Summary	Maintenance	SSO's/Date
3	RF3	RF4	1055702	6	161.9	VCP	[Fine roots at joints].	Root Cutting 11/5/2009	
3	9759 (861)	RF402	?			DIP conc	joint offset medium, alignment dip, water mark 15%csa.		
3	RF401	RF4	1055691	6	90.1	VCP	[medium and fine roots on joint].	Root Cutting 11/5/2009	
3	9762 (860)	RF505A	?			DIP conc	fine deposits 10% csa, camera stopped on debris.		
3	RF503	RF502	1055718	6	63.1	VCP	medium and fine roots at joints.		
3	RF502	RF501	1055716	6	80.8	VCP	medium and fine roots at joints.		
3	RF501	RF5	1055704	6	115.6	VCP	[fine roots at joints].	Root Cutting 11/6/2009	
3	RF6	RF7	1055693	6	95.5	VCP	medium and fine roots at joints.		
3	RF705	RF704	1055735	6	96.1	DIP	offset joint medium, water mark 10%csa.		
3	RF703	RF702	1055696	6	98.8	VCP	[medium roots at joints, camera stopped on roots] [medium and fine roots at joints, camera stopped on roots].		
3	RF708	RF706	1055697	6	72.4	VCP	[fine and medium roots at joints].	Root Cutting 11/5/2009	
3	RF701	RF7	1055695	6	222.9	VCP	[medium roots at joints, root ball, camera stopped on roots] [deposits 5%csa, medium and fine roots at joints, root ball].		
3	RF7	RF8	1055610	6	174.5	VCP	fine roots at joints, deposits 5%csa.		
3	RF9	RF10	1055694	6	78.1	VCP	medium and fine roots at joints.		
3	RF11	RF12	1055907	6	184.6	DIP	Infiltration stain, surface spalling, water mark 10% csa.		

TABLE 4.5 (Continued)
Summary and Priority of Pipe Segment Repairs for Rancheria Flat

PACP Pipeline Assessment Certification Program Priority Group	Upstream MH or Cleanout	Downstream MH or Cleanout	YOSE Inventory Asset Number	Pipe Diameter (inches)	Length (ft)	Material	Problem Summary	Maintenance	SSO's/Date
3	RF15	RF16	1055622	6	164.4	VCP	[medium and fine roots at joints, camera stopped on roots] [medium and fine roots at joints].		
3	RF16	RF17	1055624	6	110.0	VCP	medium and fine roots at joints.		
3	RF1801	RF18	?			DIP	joint offset medium, joint separated medium, multiple alignment dips, water mark 20%csa.		
3	RF19	RF20	1055140	6	42.5	DIP	joint offset large, water mark 40% csa.		
3	RF23	RF24	1055698	6	24.8	VCP	[fine roots at joints].	Root Cutting 11/5/2009	
3	RF2403	RF2402	1055920	6	79.9	DIP	joint offset medium, water mark 25%csa.		
3	RF24	RF25	1055594	6	149.1	VCP	multiple joint offset medium, medium and fine roots at joints.		
3	RF25	RF26	1055699	6	108.0	VCP	[medium and fine roots at joints].	Root Cutting 11/5/2009	
3	RF26	RF27	1055595	6	79.5	VCP	fine roots at joints.		
3	RF27	RF28	?			VCP	multiple alignment dips, medium and fine roots at joints.		
3	RF28	RF29	?				joint offset medium, fine roots at joints.		SSO<500gal, 30min, root blockage 4/30/2008
3	(RF34A)	(RF34)	?				[deposits 5% to 10% csa, camera stopped on deposits] [deposits 5% to 10% csa].		
3	RF34	RF33	1055147	6	31.0	DIP	joint separation large, deposits 5%csa.		
2	RF2	RF3	1055701	6	57.9	VCP	fine roots at joints.		
2	9747 (871)	RF5	?			VCP	alignment left 5%, camera stopped on joint.		

TABLE 4.5 (Continued)
Summary and Priority of Pipe Segment Repairs for Rancheria Flat

PACP Pipeline Assessment Certification Program Priority Group	Upstream MH or Cleanout	Downstream MH or Cleanout	YOSE Inventory Asset Number	Pipe Diameter (inches)	Length (ft)	Material	Problem Summary	Maintenance	SSO's/Date
2	RF506	RF505	1055722	4	32.3	DIP conc	water mark 25% csa		
2	RF505A	RF505	1055734	4	42.5	DIP conc	water mark 40% csa		
2	RF505	RF504	1055720	6	36.7	DIP conc	water mark 35% csa		
2	9758 (858)	RF504	?			DIP conc	water mark 15% csa		
2	RF504	RF503	1055719	6	29.3	DIP conc	water mark 15% csa		
2	RF704	RF703	1055723	6	42.5	DIP	water mark 10% csa		
2	RF709	RF708	1055738	6	42.0	VCP	water mark 45% csa		
2	RF10	RF11	1055902	6	85.1	DIP	water mark 15% csa		
2	RF12	RF13	1055908	6	164.1	DIP	water mark 10% csa		
2	RF13	MH12A	1055909	6	41.3	DIP	water mark 10% csa		
2	RF17	RF18	1055912	6	31.2	DIP	water mark 10% csa		
2	RF18	RF19	1055625	6	90.0	DIP	water mark 60% csa		
2	RF20	RF21	1055913	6	59.8	DIP	alignmet left 10%		
2	RF2402	RF2401	1055918	6	52.1	DIP	sag water level 5% csa		
2	RF2401	RF24	1055916	6	33.8	DIP	water mark 20% csa		
2	RF32	RF33	1055940	6	54.2	VCP	multiple alignment dips, joint separation medium		
2	RF33	MH16	1055960	6	14.0	VCP	alignment dip, water mark 50% csa		
0	9747	RF5	?			VCP	No CCTV Performed		
0	RF716	RF714	1055881	6	84.0	DIP	No CCTV Performed		
0	RF715	RF714	1055879	6	87.3	DIP	No CCTV Performed		

TABLE 4.5 (Continued)
Summary and Priority of Pipe Segment Repairs for Rancheria Flat

PACP Pipeline Assessment Certification Program Priority Group	Upstream MH or Cleanout	Downstream MH or Cleanout	YOSE Inventory Asset Number	Pipe Diameter (inches)	Length (ft)	Material	Problem Summary	Maintenance	SSO's/Date
0	RF714	RF713	1055877	6	77.8	DIP	No CCTV Performed.		
0	RF713	RF712	1055875	6	72.3	DIP	No CCTV Performed.		
0	RF712	RF711	1055870	8	103.7	DIP	No CCTV Performed.		
0	RF711	RF710	1055739	8	118.9	DIP	No CCTV Performed.		
0	RF711	RF710	1055740	8	117.4	DIP	No CCTV Performed.		
0	RF710	RF7	?			VCP	No CCTV Performed.		
0	RF901	RF9	1055883	6	44.2	VCP	No CCTV Performed.		
0	RF1201	RF12	1055614	6	101.0	DIP	No CCTV Performed.		
0	RF21	RF22	1055914	6	60.4	DIP	No CCTV Performed.		
0	RF22	RF14	1055962	6	155.7	DIP	No CCTV Performed.		
0	RF1401	RF14	1055911	6	34.8	VCP	No CCTV Performed.		
0	RF14	MH13	1055618	6	19.3	DIP	No CCTV Performed.		
0	RF2701	RF27	1055923	6	86.9	DIP	No CCTV Performed.		
0	RF3001	RF30	1055928	6	44.1	DIP	No CCTV Performed.		
0	RF30	RF31	1055597	6	88.4	VCP	No CCTV Performed.		
0	RF3103	RF3102	1055938	6	80.9	DIP	No CCTV Performed.		
0	RF3102	RF3101	1055936	6	165.9	DIP	No CCTV Performed.		
0	RF3101	RF31A	1055934	6	100.0	DIP	No CCTV Performed.		
0	RF31A	RF31	1055932	6	52.2	DIP	No CCTV Performed.		
0	RF31	RF32	1055589	6	149.2	VCP	No CCTV Performed.		
Notes:	? = Denotes information not provided on the Park Collection Systems FMSS Data ASSET NUMBERS spreadsheet.								
	(information) = information that is shown on plans or given in the CCTV report and does not agree with Park Collection Systems FMSS Data ASSET NUMBERS spreadsheet								
	PM = Primary Main, SM = Secondary Main, CO = Clean out Line								
	= Jetted Lines								
	= Root Cutting								
	= Heavy Cleaning								

TABLE 4.6
Summary and Priority of Pipe Segment Repairs for the Trailer Park

PACP Pipeline Assessment Certification Program Priority Group	Upstream MH or Cleanout	Downstream MH or Cleanout	YOSE Inventory Asset Number	Pipe Diameter (inches)	Length (ft)	Material	Problem Summary	Maintenance	SSOs/Date
	TP1	TP2	1056029	6	99.2	DIP	No CCTV Performed.		
	TP201	TP2	1056035	6	142.1	DIP	No CCTV Performed.		
	TP2	TP3	1056038	6	68.3	DIP	No CCTV Performed.		
	TP301	TP3	1055978	6	82.8	DIP	No CCTV Performed.		
	TP3	TP4	1056044	6	192.8	DIP	No CCTV Performed.		
	TP402	TP401	1055979	6	132.2	DIP	No CCTV Performed.		
	TP401	TP4	1055981	6	77.5	DIP	No CCTV Performed.		
	TP4	TP5	1056048	6	243.8	DIP	No CCTV Performed.		
	TP501	TP5	1056078	6	69.2	DIP	No CCTV Performed.		
	TP5	TP6	1056080	6	104.2	DIP	No CCTV Performed.		
	TP601	TP6	1055969	6	194.5	DIP	No CCTV Performed.		
	TP6	TP7	1055982	6	75.7	DIP	No CCTV Performed.		
	TP8	TP9	1055986	6	172.9	DIP	No CCTV Performed.		
	TP9	TP10	1056014	6	258.5	DIP	No CCTV Performed.		
	TP10	TP7	1056017	6	337.0	DIP	No CCTV Performed.		
	TP7	TP11	1055984	6	97.4	DIP	No CCTV Performed.		
	TP11	TP12	1056019	6	138.8	DIP	No CCTV Performed.		

TABLE 4.6 (Continued)
Summary and Priority of Pipe Segment Repairs for the Trailer Park

PACP Pipeline Assessment Certification Program Priority Group	Upstream MH or Cleanout	Downstream MH or Cleanout	YOSE Inventory Asset Number	Pipe Diameter (inches)	Length (ft)	Material	Problem Summary	Maintenance	SSO s/Date
	TP12	TP13	1055971	6	183.2	DIP	No CCTV Performed.		
	TP13	TP14	1056024	6	139.8	DIP	No CCTV Performed.		
	TP14	TP15	1056081	6	58.0	DIP	No CCTV Performed.		
	TP15	TP16	1056021	6	223.2	DIP	No CCTV Performed.		
	TP16	TP17	1056020	6	49.6	DIP	No CCTV Performed.		
	TP20	TP21	1056086	6	136.3	PVC	No CCTV Performed.		
	TP21	TP22	1056090	6	303.0	PVC	No CCTV Performed.		
	TP22	TP23	1056092	6	132.2	PVC	No CCTV Performed.		
	TP23	TP24	1056094	6	123.0	PVC	No CCTV Performed.		
	TP24	TP17	1056096	6	30.0	PVC	No CCTV Performed.		
	TP17	TP18	1056025	6	84.8	DIP	No CCTV Performed.		
	TP18	TP19	1056083	6	163.0	DIP	No CCTV Performed.		
	TP19	LIFT	1056084	6	7.6	DIP	No CCTV Performed.		SSO 20gal, 15,min, breaker tripped 6/26/2007
Notes:	? = Denotes information not provided on the Park Collection Systems FMSS Data ASSET NUMBERS spreadsheet.								
	(information) = information that is shown on plans or given in the CCTV report and does not agree with Park Collection Systems FMSS Data ASSET NUMBERS spreadsheet								
	PM = Primary Main, SM = Secondary Main, CO = Clean out Line								
		= Jetted Lines							
		= Root Cutting							
		= Heavy Cleaning							

**TABLE 4.7
Summary and Priority of Pipe Segment Repairs for Old EI Portal**

PACP Pipeline Assessment Certification Program Priority Group	Upstream MH or Cleanout	Downstream MH or Cleanout	YOSE Inventory Asset Number	Pipe Diameter (inches)	Length (ft)	Material	Problem Summary	Maintenance	SSO's/Date
5	EP3002	EP3001	1055125	4	78.0		[joint offset medium and large, crack longitudinal, multiple cracks, broken soil visible, intruding seal ring 5%csa.	Root Cutting 11/5/2009	SSO [50gal, 20min, debris blockage]12-19-2007 [30gal, 55min,grease blockage, root cutting] 10/19/2010
5	EP3001	EP30	1055129	4	98.9		[grease 90% csa, camera stopped] [multiple fractures, breaks visible soil, alignment dips, roots, camera stopped].		SSO 30gal, 55min, grease blockage10/19/2010
4	EP7	EP8	1056175	6	156.1	DIP conc.	water mark 10%csa, infiltration stain.		
4	EP1603	EP1602: EP1604	?				Deformed 16LF, multiple alignment dips, deposits 5%csa.		
4	EP3003	EP3002	1055127	4	177.0		[alignment dips, broken pipe, deposits 5%csa, roots, water mark 30%csa, camera stopped] [multiple joint offset medium, deposits 5%csa, full circumferential crack, longitudinal cracks, roots, camera stopped.].		
4	EP31	EP32	1055132	6	53.4	DIP	[Hole 8 to 4oclock root ball 90%, camera stopped] [Hole 7 to 5 o'clock root ball 75%, camera stopped].	Root Cutting 11/5/2009	SSO 60-75gal, 60min, root blockage11/6/2008
3	EP1	EP2	1056174	6	96.8	DIP conc.	Lining failure at US MH.		
3	EP2	EP3	1056166	6	194.9	DIP conc.	offset joint at wye - medium .		
3	EP5	EP6	1056190	6	114.9	DIP conc.	water mark 10%csa, infiltration stain.		
3	EP602	EP6	1056191	6	72.1	DIP conc.	water mark 5%csa, infiltration stain.		
3	EP8	EP9	1056167	6	226.2	DIP conc.	water mark 15%csa.		
3	EP11	EP12	1056198	6	237.2	DIP conc.	multiple vertical alignment dips, infiltration stain.		
3	EP1602	EP1601	1055123	6	68.0	DIP conc.	full circle crack, water mark 25%csa.		
3	EP1601	EP16	1056153	6	156.8	DIP conc.	lining failure.		
3	EP24	EP25	1056231	6	201.9	DIP conc.	multiple alignment dips, lining failures and 5%cross sectional area fine deposits.		

TABLE 4.7 (Continued)
Summary and Priority of Pipe Segment Repairs for Old EI Portal

PACP Pipeline Assessment Certification Program Priority Group	Upstream MH or Cleanout	Downstream MH or Cleanout	YOSE Inventory Asset Number	Pipe Diameter (inches)	Length (ft)	Material	Problem Summary	Maintenance	SSO's/Date
3	EP25	EP26	1056232	6	198.8	DIP conc.	alignment dip, lining failures and water mark 40%cross sectional area.		
3	EP26	EP21(20A)	1056233	6	186.4	DIP conc.	multiple alignment dips, lining failures and large joint offset, water mark 50%cross sectional area.		
3	EP22(20B)	EP23	1056176	6	104.5	DIP conc.	multiple lining failures.	Root Cutting 11/4/2009	
3	787	EP23	?				Joint separation medium, alignment dip, water mark 15%csa.		
3	NIS1	EP23A	?				lining failures, water mark 10%cross sectional area.		
3	EP23A	EP24	?				lining failures, and 5%cross sectional area fine deposits.		
3	EP23	EP29	1056168	6	259.8		multiple alignment dips, lining failures, defective tap plugged with roots.	JETTED 11/4/2009	
3	EP33	EP34	1056236	6	233.4	DIP conc.	multiple alignment dips, lining failure.	JETTED 11/4/2009	
3	EP34	EP35	1056158	6	257.0	DIP conc.	lining failures.	JETTED 11/4/2009	
3	EP35	EP36	1056238	6	254.3	DIP conc.	multiple lining failure, deposits, water mark 30%csa.		
3	EP41	EP42	1056179	6	217.0	DIP conc.	10LF roots, water mark 10%cross sectional area.		
3	EP44	EP42	1056170	6	189.1	DIP	[roots, water mark 35%csa] [water mark 15%csa, camera stopped].		
3	EP4801	EP48	1056152	4	222.6	DIP conc.	[multiple alignment dips, lining failure, deposits 90%csa, camera stopped].		
2	EP3	EP4	1056187	6	185.0	DIP conc.	water mark 15%csa.		
2	EP4	EP5	1056189	6	201.1	DIP conc.	water mark 10%csa.		

TABLE 4.7 (Continued)
Summary and Priority of Pipe Segment Repairs for Old El Portal

PACP Pipeline Assessment Certification Program Priority Group	Upstream MH or Cleanout	Downstream MH or Cleanout	YOSE Inventory Asset Number	Pipe Diameter (inches)	Length (ft)	Material	Problem Summary	Maintenance	SSO's/Date
2	EP601	EP602	1056108	4	66.0	DIP conc.	alignment right 25%.		
2	EP6	EP7	1056194	6	105.0	DIP conc.	water mark 10%csa.		
2	EP9	EP10	1056196	6	169.7	DIP conc.	water mark 10%csa.		
2	EP10	EP11	1056197	6	187.4	DIP conc.	8LF of 5%cross sectional area Fine Deposits, water mark 15%csa.		
2	EP12	EP13	1056199	6	124.5	DIP conc.	water mark 15%csa.		
2	EP13	EP14	1056200	6	116.1	DIP conc.	water mark 15%csa.		
2	EP1401	EP14	1056203	6	40.4	DIP conc.	alignment dip, water mark 10%csa.		
2	EP14	EP15	1056201	6	116.7	DIP conc.	water mark 20%csa.		
2	EP15	EP16	1056205	6	127.7	DIP conc.	water mark 15%csa.		
2	EP1606	EP1605	1056215	6	89.9	DIP conc.	water mark 15%csa.		
2	EP1605	EP1604	1056217	6	79.5	DIP conc.	water mark 10%csa.		
2	EP1604	EP1602	1056221	6	173.9	DIP conc.	sag 5%csa.		
2	EP16	EP16A	1056244	6	52.0	DIP conc.	water mark 15%csa.		
2	EP16A	EP17	1056225	6	237.3	DIP conc.	water mark 5%csa.		
2	EP17	EP18	1056226	6	52.7	DIP conc.	water mark 5%csa.		
2	EP18	EP19	1056227	6	157.1	DIP conc.	water mark 10%csa.		
2	EP19	EP20	1056228	6	118.9	DIP conc.	5%cross sectional area, Settled Gravel Deposits, water mark 10%csa.		
2	EP20	EP21(20A)	1056229	6	20.5	DIP conc.	water mark 5%csa.		

TABLE 4.7 (Continued)
Summary and Priority of Pipe Segment Repairs for Old EI Portal

PACP Pipeline Assessment Certification Program Priority Group	Upstream MH or Cleanout	Downstream MH or Cleanout	YOSE Inventory Asset Number	Pipe Diameter (inches)	Length (ft)	Material	Problem Summary	Maintenance	SSO's/Date
2	EP21(20A)	EP22(20B)	1056230	6	96.5	DIP conc.	multiple alignment dips, water mark 40%csa.	JETTED 11/4/2009	
2	EP23C	EP23	?				multiple alignment dips, material changes.	JETTED 11/4/2009	
2	EP29	EP30	1056178	6	67.9		deposits 5%csa, water mark 15&csa.		
2	EP30	EP31	1056169	6	76.6		water mark 70% csa, deposits 5% csa.		
2	785	EP31	?				deposits 5%csa, camera stopped on 90 turn.		
2	EP32	EP33	1056234	6	102.6	DIP conc.	water mark 10% csa.	JETTED 11/4/2009	
2	EP36	EP37	1056241	6	202.3	DIP conc.	multiple alignment dips, water mark 35% csa.		
2	EP37	EP38	1056242	6	223.2	DIP conc.	water mark 35% csa.		
2	EP38	EP39	1056245	6	253.4	DIP conc.	water mark 20% csa.		
2	EP39	MH28	1056254	6	14.8	DIP	water mark 30% csa.		
2	EP40	EP41	1056151	6	213.2	DIP conc.	water mark 10%csa.		
2	EP43	EP44	1056248	6	177.0	DIP conc.	[camera stopped travelling US] [camera stopped travelling DS].		
2	EP45	EP42	1056180	6	238.9	DIP conc.	water mark 10%csa.		
2	EP42	EP46	1056247	6	66.8	DIP conc.	water mark 20%csa.		
2	EP46	EP47	1056249	6	148.7	DIP conc.	water mark 10%csa.		
2	EP47	EP48	1056181	6	200.7	DIP conc.	7LF deposits 8-4oclock, water mark 15%csa.		SSO 500gal, 5hr, root blockage
2	EP50	EP51A(50A)	1056172	3	41.0	DIP	water mark 25%csa.		
2	EP51A(50A)	EP51	1056182	4	38.0	PVC	alignment dip, water mark 15%csa.		
2	EP51	EP52	1056251	4	119.8	DIP conc.	water mark 10%csa.		
2	EP52	EP48	1056183	4	108.6	DIP conc.	water mark 10%csa.		
2	EP48	EP49	1056161	6	49.1	DIP conc.	alignment dip, water mark 5%csa, repair patch.		
2	EP49	TRUNK MH36:MH37	1056165	6	17.9	VCP	alignment dip, water mark 5%csa, repair patch.		
Notes: ? = Denotes information not provided on the Park Collection Systems FMSS Data ASSET NUMBERS spreadsheet.									
(information) = information that is shown on plans or given in the CCTV report and does not agree with Park Collection Systems FMSS Data ASSET NUMBERS spreadsheet									
PM = Primary Main, SM = Secondary Main, CO = Clean out Line									
= Jetted Lines									
= Root Cutting									
= Heavy Cleaning									

**TABLE 4.8
Summary and Priority of Pipe Segment Repairs for the 16-inch Diameter Sewer Main
for Yosemite View Lodge to the EI Portal Wastewater Treatment Facility**

PACP Pipeline Assessment Certification Program Priority Group	Upstream MH or Cleanout	Downstream MH or Cleanout	YOSE Inventory Asset Number	Pipe Diameter (inches)	Length (ft)	Material	Problem Summary	Maintenance	SSO's/Date
4	MH35	MH34	1056280	16		VCP	water level 70%cross sectional area, water level sag 10%cross sectional area, tap break in.		
3	MH31A	MH31	?				longitudinal crack within 8in of joint 5 lineal feet, water level 5%cross sectional area.		
2	MH33	MH32	1056288	16	395.6	VCP	multiple alignment dips, water mark 60%cross sectional area.		
1	MH34	MH33	1056284	16		VCP	multiple alignment dips, water level sag in pipe 10%cross sectional area.		
1	MH31B	MH31A	?				water mark 5% cross sectional area .		
1	MH32	MH31A	1056312	16	398.8	VCP	tap break in, water mark 60%cross sectional area.		
1	MH31	MH30	1056314	16	401.1	VCP	water level 5%cross sectional area.		
0	MH30	MH29	1056315	16	400.0	VCP	No CCTV Performed.		
0	MH29	MH28		16		VCP	No CCTV Performed.		
0	MH28	MH27	1056293	16	422.7	VCP	No CCTV Performed.		
0	MH27	MH26	1056317	16	367.5	VCP	No CCTV Performed.		
0	MH26	MH25	1056318	16	403.9	VCP	No CCTV Performed.		
0	MH25	MH24	1056294	16	302.0	VCP	No CCTV Performed.		
0	MH24	MH23	1056319	16	304.6	VCP	No CCTV Performed.		
0	MH23	MH22	1056320	16	399.0	VCP	No CCTV Performed.		
0	MH22	MH21	1056285	16	403.8	VCP	No CCTV Performed.		
0	MH21	MH20	1056295	16	396.1	VCP	No CCTV Performed.		
0	MH20	MH19	1056296	16	397.1	VCP	No CCTV Performed.		

TABLE 4.8 (Continued)
Summary and Priority of Pipe Segment Repairs for the 16-inch Diameter Sewer Main
for Yosemite View Lodge to the EI Portal Wastewater Treatment Facility

PACP Pipeline Assessment/Certification Program Priority Group	Upstream MH or Cleanout	Downstream MH or Cleanout	YOSE Inventory Asset Number	Pipe Diameter (inches)	Length (ft)	Material	Problem Summary	Maintenance	SSO's/Date
0	MH19	MH18	1056297	16	401.5	VCP	No CCTV Performed.		
0	MH18	MH17	1056298	16	405.8	VCP	No CCTV Performed.		
0	MH17	MH16	1056299	16	375.5	VCP	No CCTV Performed.		
0	MH16	MH15	1056322	16	401.9	VCP	No CCTV Performed.		
0	MH15	MH14	1056300	16	394.6	VCP	No CCTV Performed.		
0	MH14	MH13	1056325	16	328.9	VCP	No CCTV Performed.		
0	MH13	MH12A	1056327	16	111.5	VCP	No CCTV Performed.		
0	MH12A	MH12	1056302	16	156.8	VCP	No CCTV Performed.		
0	MH12	MH11	1056328	16	291.9	VCP	No CCTV Performed.		
0	MH11	MH10	1056329	16	366.2	VCP	No CCTV Performed.		
0	MH10	MH9	1056303	16	407.2	VCP	No CCTV Performed.		
0	MH9	MH8	1056305	16	383.7	VCP	No CCTV Performed.		
0	MH8	MH7	1056306	16	214.1	VCP	No CCTV Performed.		
0	MH7	MH6	1056308	16	190.4	VCP	No CCTV Performed.		
0	MH6	MH5	1056331	16	190.0	VCP	No CCTV Performed.		
0	MH5	MH4	1056332	16	192.1	VCP	No CCTV Performed.		
0	MH5	MH4	1056333	16	416.6	VCP	No CCTV Performed.		
0	MH4	MH3	1056309	16	373.8	VCP	No CCTV Performed.		
0	MH3	MH2		16		VCP	No CCTV Performed.		
0	MH2	MH1	1056310	16	237.5	VCP	No CCTV Performed.		
Notes:	? = Denotes information not provided on the Park Collection Systems FMSS Data ASSET NUMBERS spreadsheet.								
	(information) = information that is shown on plans or given in the CCTV report and does not agree with Park Collection Systems FMSS Data ASSET NUMBERS spreadsheet								
	PM = Primary Main, SM = Secondary Main, CO = Clean out Line								
	= Jetted Lines								
	= Root Cutting								
	= Heavy Cleaning								

YOSEMITE NATIONAL PARK UTILITIES BRANCH

SEWER SYSTEM MANAGEMENT PLAN

EL PORTAL

SANITARY SEWER SYSTEM (CS 5SSO10735)

4.4.2 CAPITAL IMPROVEMENT PLAN

The capital improvement program or plan (CIP) for the SSMP is limited to those capital improvements that will prevent the occurrence of SSOs. For example, CIP projects will likely focus on repairs, rehabilitation, or replacing existing sewer infrastructures to prevent SSOs.

The CIP for El Portal and its developed areas are based on the sewer condition assessment reported in Section 4.4.1. The PACP defect grading system presented in Exhibit 4.3 uses a scale of 1 to 5, with 1 representing a minimal defect and 5 representing the worst defect.

However, NPS's FMSS tracks and schedules sewer system rehabilitation and repair projects at three levels of urgency; therefore, the five PACP grades of severity have been grouped into three categories of projects ranging from short-term to long-term projects using the FMSS severity indexes presented in Table 4.9 as a guideline.

TABLE 4.9
Grading Criteria for Determining Urgency for
Sewer System Rehabilitation and Repair
(Comparison of FMSS Urgency Index or Code and PACP Severity Grade)

Grading Criteria	FMSS Urgency Index Code	PACP Severity Grade
<u>Emergency Repairs</u> that should be performed within 1 to 2 years	1	5
<u>Planned Repairs</u> that should be scheduled for completion within 2 to 10 years. System inspections should be performed in accordance with Table 4.3 to ascertain whether the priority or urgency for repair should be adjusted.	2	4-3
<u>Long Term Planned Repairs</u> that should be scheduled for repair or replacement within 10 to 20 years; however, the suspected sewer condition should be re-inspected at 10 year intervals to ascertain whether the priority or urgency for repair should be upgraded.	3	2-1

YOSEMITE NATIONAL PARK UTILITIES BRANCH

SEWER SYSTEM MANAGEMENT PLAN

EL PORTAL

SANITARY SEWER SYSTEM (CS 5SSO10735)

FMSS Urgency Index Code No. 1 Capital Improvement Projects

The condition assessment identified several elements of the El Portal sewer system with PACP defect grading levels of 5. Refer to Table 4.7 for specific project description and project priority based on the project rating criteria presented in Exhibit 4.3. The following projects are recommended to be completed within the next two years and are shown on Figures 4.10 through 4.16.

1. Replace Pipeline from EP 3002 to EP 3001 (Asset 1055125): This pipe segment has offset joints, longitudinal pipe cracks and intruding seal rings. SSO has occurred from this pipe segment. The project would replace 78 lf of piping from EP 3002 to EP 3001.

Class C cost estimate is \$12,852.

2. Replace Pipeline from EP 3001 to EP 30 (Asset 1055129): This pipe segment has alignment dips, multiple fractures and heavy root growth. SSO has occurred from this pipe segment. The project would replace 99 lf of piping from EP 3001 to EP 30.

Class C cost estimate is \$21,857.

FMSS Urgency Index Code No. 2 Capital Improvement Projects

The condition assessment identified many elements of Rancheria Flat and Old El Portal sewer systems with PACP defect grading levels between 3 and 4. Refer to Tables 4.5 and 4.7 for specific project descriptions and project priority based on the project rating criteria presented in Exhibit 4.3. However, there are no CCTV inspection results for the sewer systems within the Maintenance Complex and the Trailer Court; therefore, capital improvement projects cannot be identified for the Maintenance Complex and the Trailer Court. Several of the elements or deficiencies do not necessitate an improvement project and have been scheduled for increased maintenance as identified in Section 4.3. The following are projects within Rancheria Flat (RF) and Old El Portal (EP) that are recommended to be completed within the next 2 to 10 years and are also mapped in Figures 4.10 through 4.16.

YOSEMITE NATIONAL PARK UTILITIES BRANCH

SEWER SYSTEM MANAGEMENT PLAN

EL PORTAL

SANITARY SEWER SYSTEM (CS 5SSO10735)

1. Replace Pipeline from RF 101 to RF 1 (Asset 1055133): This pipe segment has a multiple vertical alignment dips, pipe cracks, large offset joint and significant root growth. The project would replace 305 lf of pipeline from RF 101 to RF 1.

Class C cost estimate is \$76,564.

2. Replace Pipeline from RF 304 to RF 303 (Asset 1055641): This pipe segment has multiple vertical alignment dips, offset pipe joints, intruding pipe seals, and root growth. The project would replace 68 lf of pipeline from RF 304 to RF 303.

Class C cost estimate is \$14,152.

3. Replace Pipeline from RF 303 to RF 302 (Asset 1055148): This pipe segment has multiple pipe breaks and a pipe hole. The project would replace the 44 lf of pipeline from RF 303 to RF 302.

Class C cost estimate is \$11,732.

4. Replace Pipeline from RF 302 to RF 301 (Asset 1055150): This pipe segment has a multiple vertical dips, significant pipe breaks and cracks with fine root growth. The project would replace the 80 lf of pipeline from RF 302 to RF 301.

Class C cost estimate is \$15,362.

5. Replace Pipeline from RF 402 to RF 401 (Asset 1055172): This pipe segment has a significant pipe breaks and cracks with clumps of root growth. The project would replace the 261 lf of pipeline from RF 402 to RF 401.

Class C cost estimate is \$64,062.

YOSEMITE NATIONAL PARK UTILITIES BRANCH

SEWER SYSTEM MANAGEMENT PLAN

EL PORTAL

SANITARY SEWER SYSTEM (CS 5SSO10735)

6. Replace Pipeline from RF 4 to RF 5 (Asset 1055135): This pipe segment has longitudinal cracks with significant root growth at pipe joints. The project would replace the 127 lf of pipeline from RF 4 to RF 5.

Class C cost estimate is \$35,011.

7. Replace Pipeline from RF 5 to RF 6 (Asset 1055137): This pipe segment has multiple circumferential cracks with a significant root growth. The project would replace the 298 lf of pipeline from RF 5 to RF 6.

Class C cost estimate is \$73,610.

8. Replace Pipeline from RF 707 to RF 706 (Asset 1055138): This pipe segment has longitudinal fractures with deposits of sand. The project would replace the 200 lf of pipeline from RF 707 to RF 706.

Class C cost estimate is \$52,179.

9. Replace Pipeline from RF 706 to RF 702 (Asset 1055180): This pipe segment has a significant pipe breaks and cracks with fine root growth. The project would replace the 200 lf of pipeline from RF 706 to RF 702.

Class C cost estimate is \$31,179.

10. Replace Pipeline from RF 702 to RF 701 (Asset 1055174): This pipe segment has a significant offset pipe joints and root growth. The project would replace the 60 lf of pipeline from RF 702 to RF 701.

Class C cost estimate is \$14,753.

11. Replace Pipeline from RF 8 to RF 9 (Asset 1055169): This pipe segment has a multiple pipe breaks with soil exposed and root growth at joints. The project would replace the 190 lf of pipeline from RF 8 to RF 9.

Class C cost estimate is \$44,661.

YOSEMITE NATIONAL PARK UTILITIES BRANCH

SEWER SYSTEM MANAGEMENT PLAN

EL PORTAL

SANITARY SEWER SYSTEM (CS 5SSO10735)

12. Replace Pipeline from RF 29 to RF 30 (Asset 1055181): This pipe segment has a significant offset pipe joints and root growth. The project would replace the 70 lf of pipeline from RF 29 to RF 30.

Class C cost estimate is \$23,951.

13. Replace Pipeline from EP 7 to EP 8 (Asset 1056175): This pipe segment has a significant pipe sagging and multiple pipe joint offsets and separations. The project would replace the 156 lf of pipeline from EP 7 to EP 8.

Class C cost estimate is \$42,702.

14. Replace Pipeline from EP 1603 to EP 1602/EP1604 (Asset unknown): This pipe segment has a significant pipe sagging and deformity. The project would replace the pipeline from EP 1603 to EP 1602/1604.

Class C cost estimate is \$30,850.

15. Replace Pipeline from EP 3003 to EP 3002 (1055127): This piping has a significant pipe alignment dips, broken pipe segments, and multiple pipe joint offsets and separations. The project would replace the 177 lf of piping from EP 3003 to EP 3002.

Class C cost estimate is \$25,666.

16. Replace Pipeline from EP 31 to EP 32 (Asset 1055132): This pipe segment has significant pipe holes. SSO has occurred from this pipe segment. The project would replace 53 lf of piping from EP 31 to EP 32.

Class C cost estimate is \$12,639.

YOSEMITE NATIONAL PARK UTILITIES BRANCH

SEWER SYSTEM MANAGEMENT PLAN

EL PORTAL

SANITARY SEWER SYSTEM (CS 5SSO10735)

17. Replace Pipeline from EP 22 (EP20B) to EP 23 (Asset 1056176): This pipe segment has multiple lining failures and heavy root growth. The project would replace 105 lf of piping from EP 22 to EP 23.

Class C cost estimate is \$30,062.

18. Replace Pipeline from MH 35 to MH 34 (Asset 1056280): This pipe segment has a significant vertical pipe alignment and is nearing pipe capacity. The project would replace 252 lf of 16 inch diameter pipeline from MH 35 to MH 34.

Class C cost estimate is \$86,350.

19. Repair Pipeline from RF 1 to RF 2 (Asset 1055629): This pipe segment has a significant offset pipe joints and root growth. The project would require a spot repair approximately 5 feet from RF 1.

Class C cost estimate is \$8,303.

20. Replace Pipeline from RF 301 to RF 3 (Asset 1055703): This pipe segment has a significant offset pipe joints and root growth. The project would replace the 109 lf of pipeline from RF 301 to RF 3.

Class C cost estimate is \$18,286.

21. Replace Pipeline from RF 3 to RF 4 (Asset 1055702): This pipe segment has a significant pipe sagging and deformity. The project would replace 162 lf of pipeline from RF 3 to RF 4.

Class C cost estimate is \$42,530.

22. Replace Pipeline from RF 11 to RF 12 (Asset 1055907): This pipe segment has infiltration stains and surface spalling. The project would replace 185 lf of pipeline from RF 11 to RF 12.

Class C cost estimate is \$48,986.

YOSEMITE NATIONAL PARK UTILITIES BRANCH

SEWER SYSTEM MANAGEMENT PLAN

EL PORTAL

SANITARY SEWER SYSTEM (CS 5SSO10735)

23. Replace Pipeline from RF 1801 to RF 18 (Asset unknown): This pipe segment has offset joints, vertical alignment dips, and separated joints. The project would replace piping from RF 1801 to RF 18.

Class C cost estimate is \$11,228.

24. Replace Pipeline from RF 19 to RF 20 (Asset 1055140): This pipe segment has a large offset joint. This project would replace 43 lf of pipeline from RF 19 to RF 20.

Class C cost estimate is \$11,631.

25. Replace Pipeline from RF 2403 to RF 2402 (Asset 1055920): This pipe segment has a medium offset joints. The project would replace the 80 lf of pipeline from RF 2403 to RF 2402.

Class C cost estimate is \$24,602.

26. Replace Pipeline from RF 24 to RF 25 (Asset 1055594): This pipe segment has multiple offset joints with extensive root growth. The project would replace 149 lf of pipeline from RF 24 to RF 25.

Class C cost estimate is \$39,749.

27. Replace Pipeline from RF 34 to RF 33 (Asset 1055147): This pipe segment has large separated joint. The project would replace 31 lf of pipeline from RF 34 to RF 33.

Class C cost estimate is \$10,421.

28. Repair Pipeline between EP 1 and EP 2 (Asset 1056174): This pipe segment has lining failure. The project would require a spot repair of lining failure near EP 1.

Class C cost estimate is \$9,563.

YOSEMITE NATIONAL PARK UTILITIES BRANCH

SEWER SYSTEM MANAGEMENT PLAN

EL PORTAL

SANITARY SEWER SYSTEM (CS 5SSO10735)

29. Repair Pipeline between EP 2 and EP 3 (Asset 1056166): The pipe segment has several broken taps that will require spot repairs of three taps.

Class C cost estimate is \$15,298.

30. Repair Pipeline between EP 5 and EP 6 (Asset 1056190): This pipe segment has an infiltration stain. The project will require a spot repair near EP 6 to prevent infiltration.

Class C cost estimate is \$9,563.

31. Repair Pipeline between EP 602 and EP 6 (Asset 1056191): This pipe segment has an infiltration stain. The project will require a spot repair near EP 6 to prevent infiltration.

Class C cost estimate is \$9,563.

32. Replace Pipeline between EP11 and EP 12 (Asset 1056198): This pipe segment has infiltration stains and multiple vertical alignment dips. The project will require pipe replacement between EP 11 and EP 12.

Class C cost estimate is \$61,727.

33. Repair Pipeline between EP 1602 and EP 1601 (Asset 1055123): This pipe segment has a full circumferential crack. The project will require a spot repair within 28 feet of EP 1602.

Class C cost estimate is \$9,563.

34. Repair Pipeline between EP 1601 and EP 16 (Asset 1056153): This pipe segment has a lining failure. The project will require a spot repair within 100 feet of EP 1601.

Class C cost estimate is \$8,303.

YOSEMITE NATIONAL PARK UTILITIES BRANCH

SEWER SYSTEM MANAGEMENT PLAN

EL PORTAL

SANITARY SEWER SYSTEM (CS 5SSO10735)

35. Replace Pipeline between EP 23A and EP 24 (Asset unknown): This pipe segment has multiple lining failures. The project will require a pipe replacement between EP 23A and EP 24.

Class C cost estimate is \$52,179.

36. Replace Pipeline between EP 23 and EP 29 (Asset 1056168): This pipe segment has multiple vertical alignment dips and lining failures with defective taps. The project will require a pipe replacement between EP 23 and EP 29.

Class C cost estimate is \$34,919.

37. Replace Pipeline between EP 24 and EP 25 (Asset 1056231): This pipe segment has multiple vertical alignment dips and lining failures. The project will require pipe replacement between EP 24 and EP 25.

Class C cost estimate is \$29,071.

38. Replace Pipeline between EP 25 and EP 26 (Asset 1056232): This pipe segment has multiple vertical alignment dips and lining failures with defective taps. The project will require a pipe replacement between EP 23 and EP 29.

Class C cost estimate is \$28,768.

39. Replace Pipeline between EP 26 and EP 21 (20A) (Asset 1056233): This pipe segment has multiple vertical alignment dips and lining failures with defective taps. The project will require a pipe replacement between EP 23 and EP 29.

Class C cost estimate is \$27,457.

YOSEMITE NATIONAL PARK UTILITIES BRANCH

SEWER SYSTEM MANAGEMENT PLAN

EL PORTAL

SANITARY SEWER SYSTEM (CS 5SSO10735)

40. Replace Pipeline between EP 33 and EP 34 (Asset 1056236): This pipe segment has multiple vertical alignment dips and lining failures. The project will require a pipe replacement between EP 33 and EP 34.

Class C cost estimate is \$39,126.

41. Replace Pipeline between EP 34 and EP 35 (Asset 1056158): This pipe segment has multiple vertical alignment dips and lining failures with defective taps. The project will require 257 lf of pipe replacement between EP 23 and EP 29.

Class C cost estimate is \$64,646.

42. Replace Pipeline between EP 4801 and EP 48 (Asset 1056152): This pipe segment has multiple vertical alignment dips and lining failures. The project will require 223 lf of pipe replacement between EP 4801 and EP 48.

Class C cost estimate is \$39,315.

43. Repair Pipeline between MH 31A and MH 31 (Asset unknown): This pipe segment has longitudinal cracks within 7 feet of MH 31. The project will require a spot repair near MH 31.

Class C cost estimate is \$13,276.

YOSEMITE NATIONAL PARK UTILITIES BRANCH

SEWER SYSTEM MANAGEMENT PLAN EL PORTAL SANITARY SEWER SYSTEM (CS 5SSO10735)

FMSS Urgency Index Code No. 3 Capital Improvement Projects

The condition assessment identified several elements of the Rancheria Flats and Old El Portal sewer systems with PACP defect grading levels of between 1 to 2 (The project rating criteria are presented in Exhibit 4.3). Several of these elements do not necessitate an improvement project and have been scheduled for regular maintenance as identified in Section 4.3. Note that 2009 CCTV inspection results are not available for the Maintenance Complex and Trailer Court/Park, therefore, system improvements cannot be identified for the Maintenance Complex and Trailer Court/Park areas.

The Capital Improvement Plan should be re-evaluated following the collection of sewer flow measurements and future sewer system observations and inspections.

Capital improvement projects that are required to prevent SSOs are created by the Utilities Branch and/or the Design and Engineering Branch staff using one or a combination of the following:

- Routine visual manhole inspections per item 1 in Section 4.3.2,
- Internal pipe inspection per item 2 in Section 4.3.2,
- Lift station cleaning and inspection per Section 4.3.3,
- Force main cleaning and inspection per Section 4.3.4,
- Oil/water separator cleaning and inspection per Section 4.3.5 and/or
- Sewer capacity assessments per Section 8.2.

Projects that may result from the above described activities may include:

- Replacing entire pipe segments and manholes;
- Inserting a new pipe of equal or greater diameter by pipe bursting;
- Reconstructing existing piping by chemical grouting, slip lining, or cured-in-place pipelining;
- Lining manholes;
- Disconnecting and/or removing piping and/or manhole cross-connections;
- Replacing or installing new larger piping and/or pumps to increase system capacity; or
- Providing equipment redundancy or alternative power to better facilitate system or equipment failures.

4/2/13 17:05 SEH R18 G:\CLIENTS\NPS\10-0380C\YOSE\PMIS\DRAWINGS\CIV\F4.2-4.16_SITE_EL_POD.DWG XREFS: G:\CLIENTS\NPS\10-0380C\YOSE\PMIS\DRAWINGS\BASES\EL\PORTAL.DWG; G:\CLIENTS\NPS\10-0380C\YOSE\PMIS\DRAWINGS\BASES\EP-UTILS.DWG;

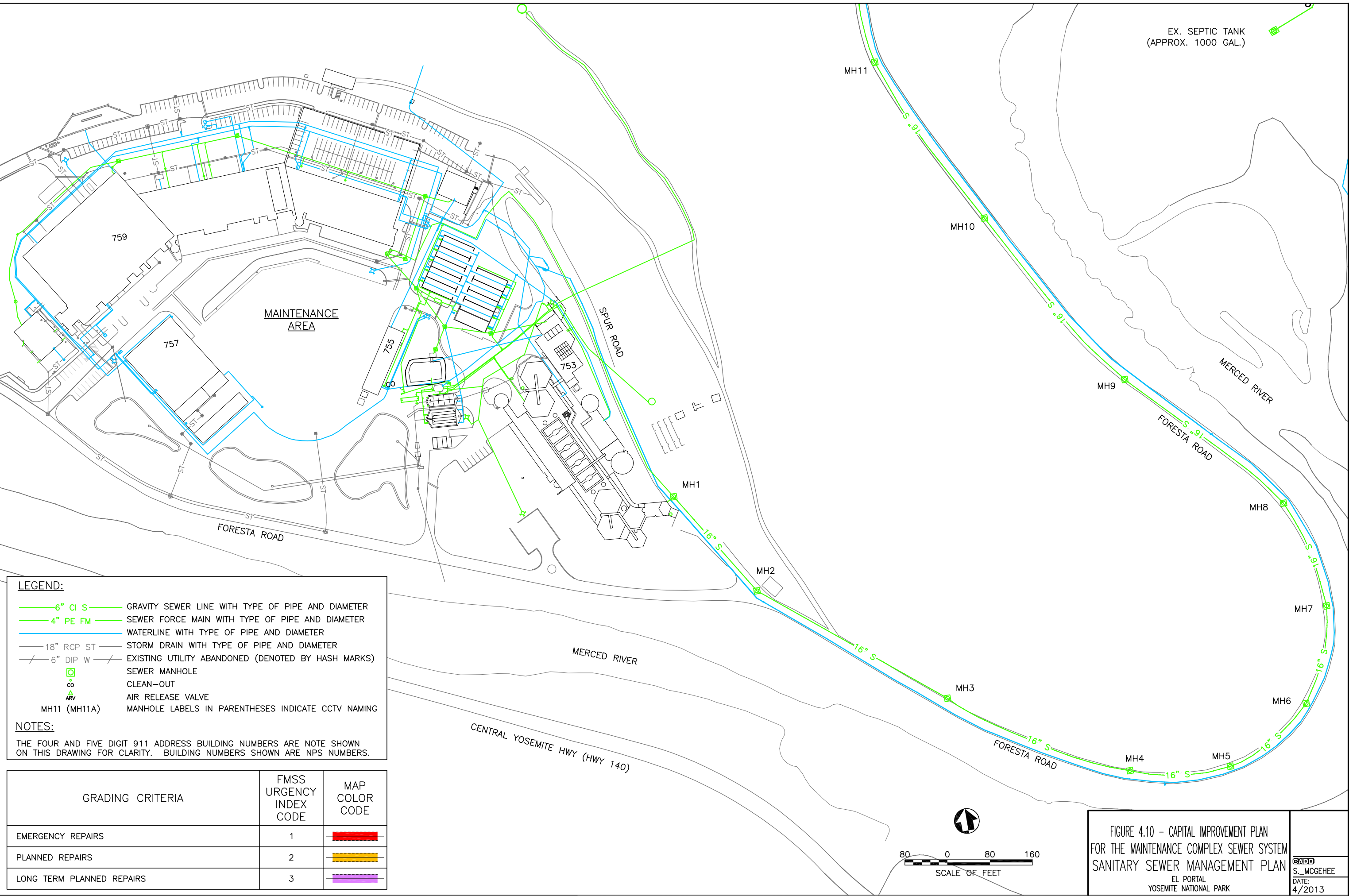

LEGEND:

- 6" CI S — GRAVITY SEWER LINE WITH TYPE OF PIPE AND DIAMETER
- 4" PE FM — SEWER FORCE MAIN WITH TYPE OF PIPE AND DIAMETER
- — WATERLINE WITH TYPE OF PIPE AND DIAMETER
- 18" RCP ST — STORM DRAIN WITH TYPE OF PIPE AND DIAMETER
- - - 6" DIP W — EXISTING UTILITY ABANDONED (DENOTED BY HASH MARKS)
- — SEWER MANHOLE
- ⊙ — CLEAN-OUT
- ▲ — AIR RELEASE VALVE
- MH11 (MH11A) — MANHOLE LABELS IN PARENTHESES INDICATE CCTV NAMING

NOTES:

THE FOUR AND FIVE DIGIT 911 ADDRESS BUILDING NUMBERS ARE NOTE SHOWN ON THIS DRAWING FOR CLARITY. BUILDING NUMBERS SHOWN ARE NPS NUMBERS.

GRADING CRITERIA	FMSS URGENCY INDEX CODE	MAP COLOR CODE
EMERGENCY REPAIRS	1	
PLANNED REPAIRS	2	
LONG TERM PLANNED REPAIRS	3	

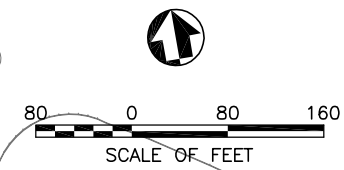
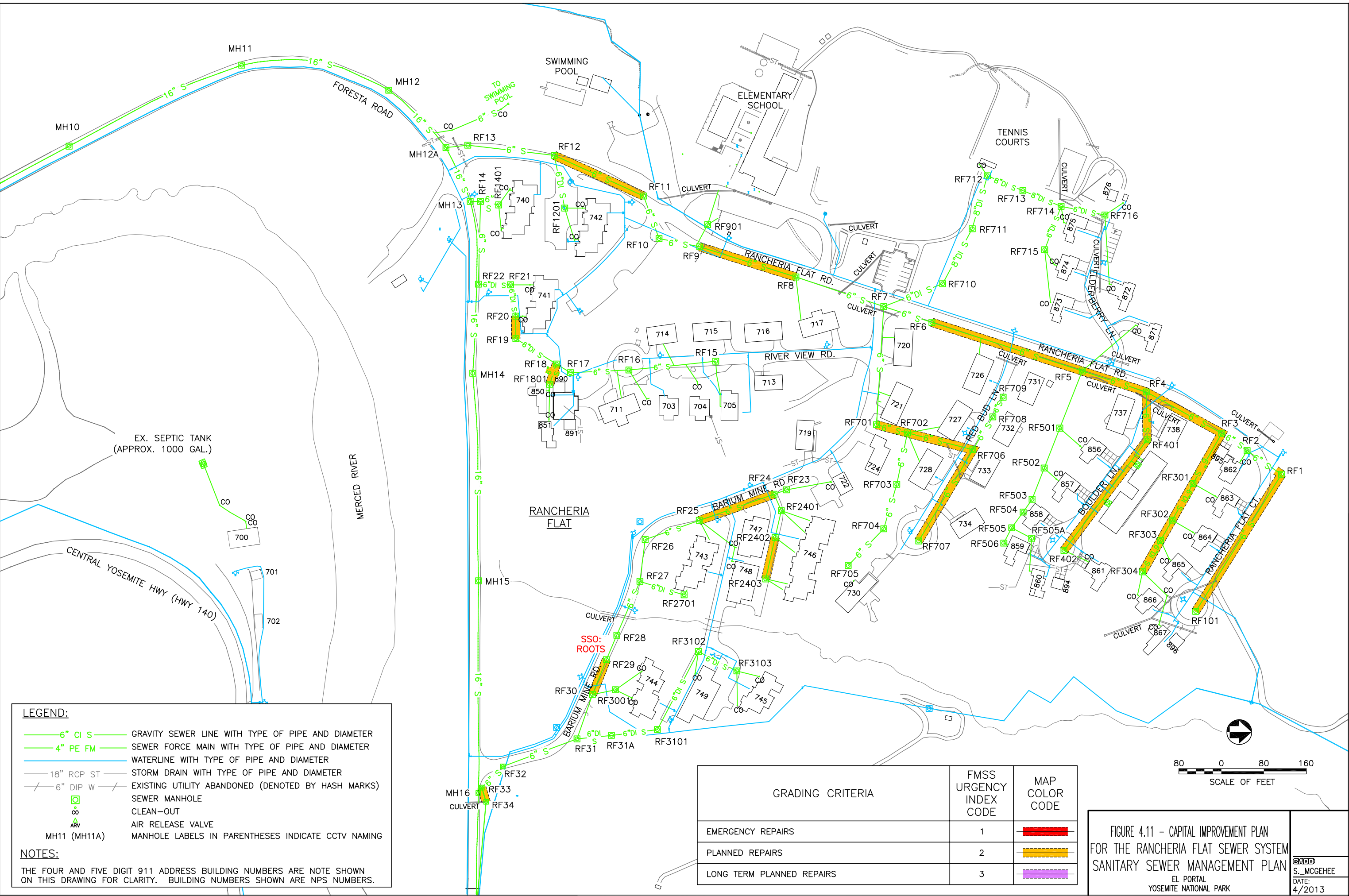

FIGURE 4.10 - CAPITAL IMPROVEMENT PLAN FOR THE MAINTENANCE COMPLEX SEWER SYSTEM
SANITARY SEWER MANAGEMENT PLAN
 EL PORTAL
 YOSEMITE NATIONAL PARK

GARD S. MCGEEHEE
 DATE: 4/2013

4/2/13 17:05 SEH R18 G:\CLIENTS\NPS\10-0380C\YOSE\PMIS\DRAWINGS\CIV\F4-2-4.16_SITE_EL_PODWG.XREFS: G:\CLIENTS\NPS\10-0380C\YOSE\PMIS\DRAWINGS\BASES\EL\PORTAL.DWG: G:\CLIENTS\NPS\10-0380C\YOSE\PMIS\DRAWINGS\BASES\EP\UTILS.DWG:



LEGEND:

- 6" CI S GRAVITY SEWER LINE WITH TYPE OF PIPE AND DIAMETER
- 4" PE FM SEWER FORCE MAIN WITH TYPE OF PIPE AND DIAMETER
- WATERLINE WITH TYPE OF PIPE AND DIAMETER
- 18" RCP ST STORM DRAIN WITH TYPE OF PIPE AND DIAMETER
- - - 6" DIP W EXISTING UTILITY ABANDONED (DENOTED BY HASH MARKS)
- CO SEWER MANHOLE
- CO CLEAN-OUT
- ▲ ARV AIR RELEASE VALVE
- MH11 (MH11A) MANHOLE LABELS IN PARENTHESES INDICATE CCTV NAMING

NOTES:

THE FOUR AND FIVE DIGIT 911 ADDRESS BUILDING NUMBERS ARE NOTE SHOWN ON THIS DRAWING FOR CLARITY. BUILDING NUMBERS SHOWN ARE NPS NUMBERS.

GRADING CRITERIA	FMSS URGENCY INDEX CODE	MAP COLOR CODE
EMERGENCY REPAIRS	1	
PLANNED REPAIRS	2	
LONG TERM PLANNED REPAIRS	3	

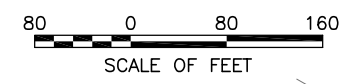

FIGURE 4.11 - CAPITAL IMPROVEMENT PLAN FOR THE RANCHERIA FLAT SEWER SYSTEM
 SANITARY SEWER MANAGEMENT PLAN
 EL PORTAL
 YOSEMITE NATIONAL PARK

DATE: 4/2013
 S. MCGEEHEE

4/2/13 17:05 SEH R18 G:\CLIENTS\NPS\10-0380C\YOSE\PMIS\DRAWINGS\CIV\F4-2-4.16_SITE_EL_POD.DWG XREFS: G:\CLIENTS\NPS\10-0380C\YOSE\PMIS\DRAWINGS\BASES\EL\PORTAL.DWG; G:\CLIENTS\NPS\10-0380C\YOSE\PMIS\DRAWINGS\BASES\EP-UTILS.DWG;

LEGEND:

	6" CI S	GRAVITY SEWER LINE WITH TYPE OF PIPE AND DIAMETER
	4" PE FM	SEWER FORCE MAIN WITH TYPE OF PIPE AND DIAMETER
	WATERLINE	WATERLINE WITH TYPE OF PIPE AND DIAMETER
	18" RCP ST	STORM DRAIN WITH TYPE OF PIPE AND DIAMETER
	6" DIP W	EXISTING UTILITY ABANDONED (DENOTED BY HASH MARKS)
	MH	SEWER MANHOLE
	CO	CLEAN-OUT
	ARV	AIR RELEASE VALVE
MH11 (MH11A)		MANHOLE LABELS IN PARENTHESES INDICATE CCTV NAMING

NOTES:

THE FOUR AND FIVE DIGIT 911 ADDRESS BUILDING NUMBERS ARE NOTE SHOWN ON THIS DRAWING FOR CLARITY. BUILDING NUMBERS SHOWN ARE NPS NUMBERS.

GRADING CRITERIA	FMSS URGENCY INDEX CODE	MAP COLOR CODE
EMERGENCY REPAIRS	1	
PLANNED REPAIRS	2	
LONG TERM PLANNED REPAIRS	3	

NO CCTV RESULTS FOR TRAILER COURT.

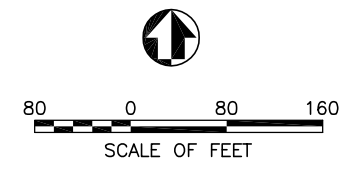
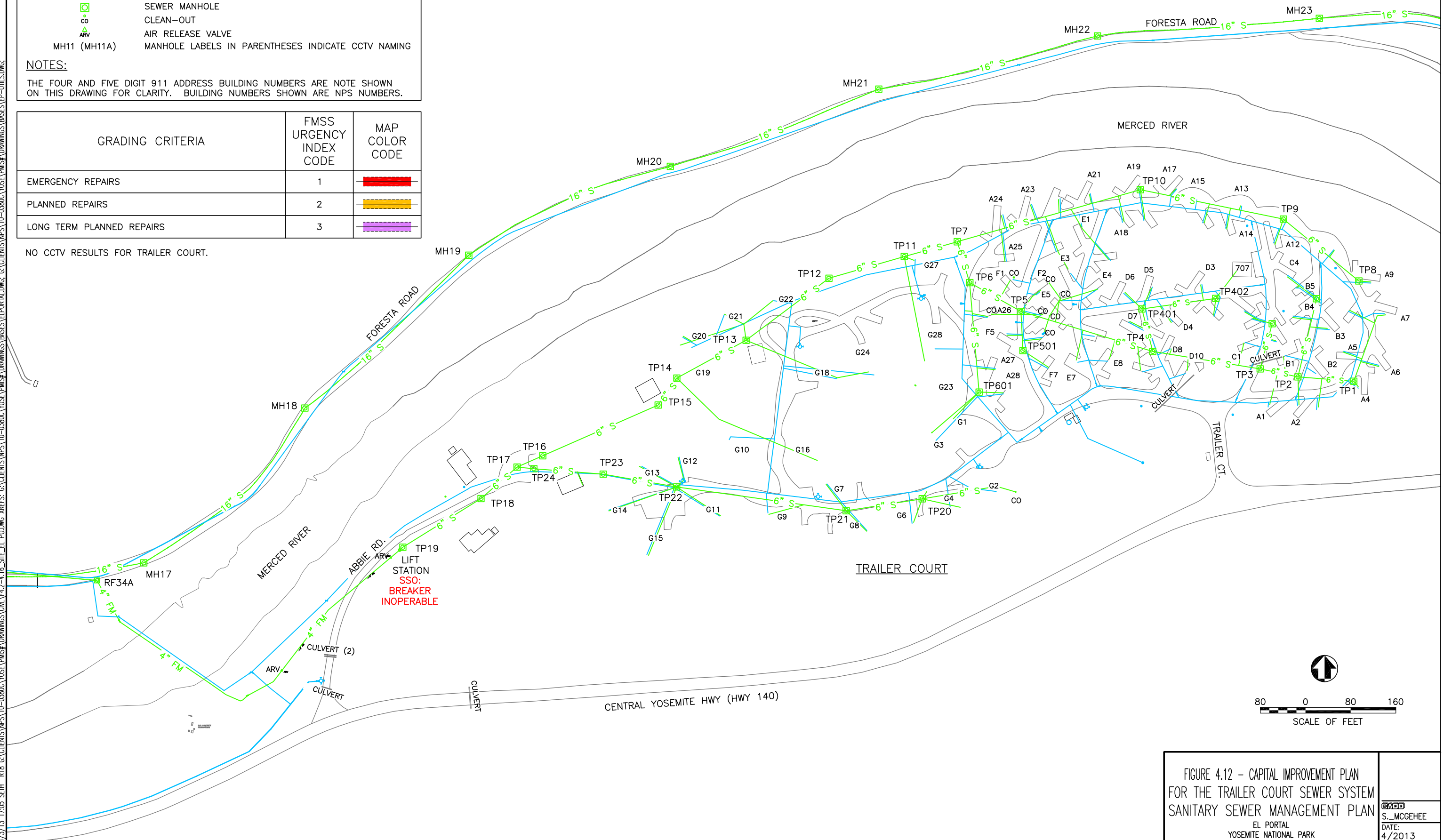

FIGURE 4.12 - CAPITAL IMPROVEMENT PLAN
FOR THE TRAILER COURT SEWER SYSTEM
SANITARY SEWER MANAGEMENT PLAN
EL PORTAL
YOSEMITE NATIONAL PARK

GADD
S._MCGEEHEE
DATE:
4/2013

4/2/13 17:05 SEH R18 G:\CLIENTS\NPS\10-0380C\YOSE\PMIS\DRAWINGS\CIV\F4-2-4.16_SITE_EL_PORTAL.DWG, G:\CLIENTS\NPS\10-0380C\YOSE\PMIS\DRAWINGS\BASES\ELPORTAL.DWG, G:\CLIENTS\NPS\10-0380C\YOSE\PMIS\DRAWINGS\BASES\EP-UTILS.DWG,

LEGEND:

- 6" CI S GRAVITY SEWER LINE WITH TYPE OF PIPE AND DIAMETER
- 4" PE FM SEWER FORCE MAIN WITH TYPE OF PIPE AND DIAMETER
- WATERLINE WITH TYPE OF PIPE AND DIAMETER
- 18" RCP ST STORM DRAIN WITH TYPE OF PIPE AND DIAMETER
- - - 6" DIP W EXISTING UTILITY ABANDONED (DENOTED BY HASH MARKS)
- SEWER MANHOLE
- ⊕ CLEAN-OUT
- △ ARV AIR RELEASE VALVE
- MH11 (MH11A) MANHOLE LABELS IN PARENTHESES INDICATE CCTV NAMING

NOTES:
 THE FOUR AND FIVE DIGIT 911 ADDRESS BUILDING NUMBERS ARE NOTE SHOWN ON THIS DRAWING FOR CLARITY. BUILDING NUMBERS SHOWN ARE NPS NUMBERS.

GRADING CRITERIA	FMSS URGENCY INDEX CODE	MAP COLOR CODE
EMERGENCY REPAIRS	1	
PLANNED REPAIRS	2	
LONG TERM PLANNED REPAIRS	3	

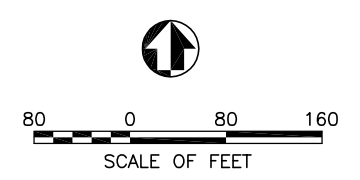
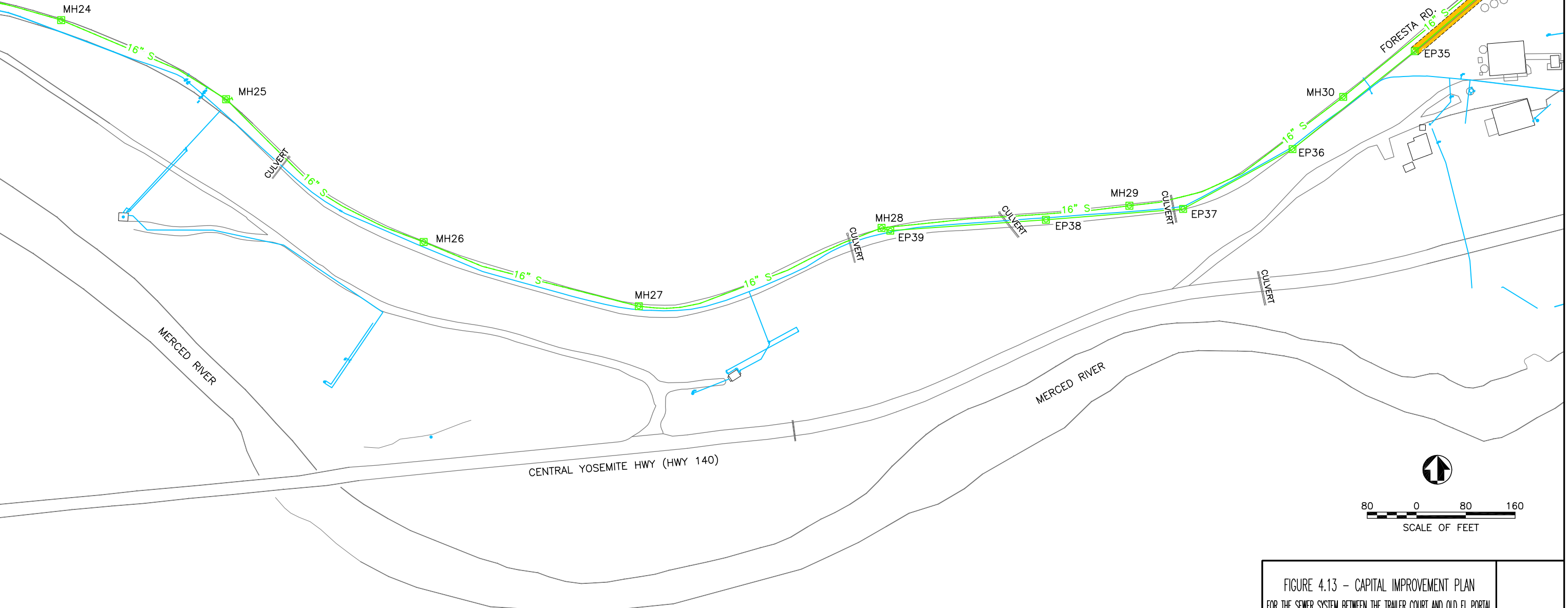

FIGURE 4.13 - CAPITAL IMPROVEMENT PLAN FOR THE SEWER SYSTEM BETWEEN THE TRAILER COURT AND OLD EL PORTAL SANITARY SEWER MANAGEMENT PLAN	
EL PORTAL YOSEMITE NATIONAL PARK	
GADD S. MCGEEHEE DATE: 4/2013	

4/2/13 17:05 SEH R18 G:\CLIENTS\NPS\10-0380C\YOSE.PMIS\DRAWINGS\CIV\F4-2-4.16_SITE_EL_PODWG.XREFS: G:\CLIENTS\NPS\10-0380C\YOSE.PMIS\DRAWINGS\BASES\ELPORTAL.DWG: G:\CLIENTS\NPS\10-0380C\YOSE.PMIS\DRAWINGS\BASES\EP-UTILS.DWG:

LEGEND:

- 6" CI S GRAVITY SEWER LINE WITH TYPE OF PIPE AND DIAMETER
- 4" PE FM SEWER FORCE MAIN WITH TYPE OF PIPE AND DIAMETER
- WATERLINE WITH TYPE OF PIPE AND DIAMETER
- 18" RCP ST STORM DRAIN WITH TYPE OF PIPE AND DIAMETER
- - - 6" DIP W EXISTING UTILITY ABANDONED (DENOTED BY HASH MARKS)
- SEWER MANHOLE
- CLEAN-OUT
- ARV AIR RELEASE VALVE
- MH11 (MH11A) MANHOLE LABELS IN PARENTHESES INDICATE CCTV NAMING

NOTES:

THE FOUR AND FIVE DIGIT 911 ADDRESS BUILDING NUMBERS ARE NOTE SHOWN ON THIS DRAWING FOR CLARITY. BUILDING NUMBERS SHOWN ARE NPS NUMBERS.

GRADING CRITERIA	FMSS URGENCY INDEX CODE	MAP COLOR CODE
EMERGENCY REPAIRS	1	
PLANNED REPAIRS	2	
LONG TERM PLANNED REPAIRS	3	

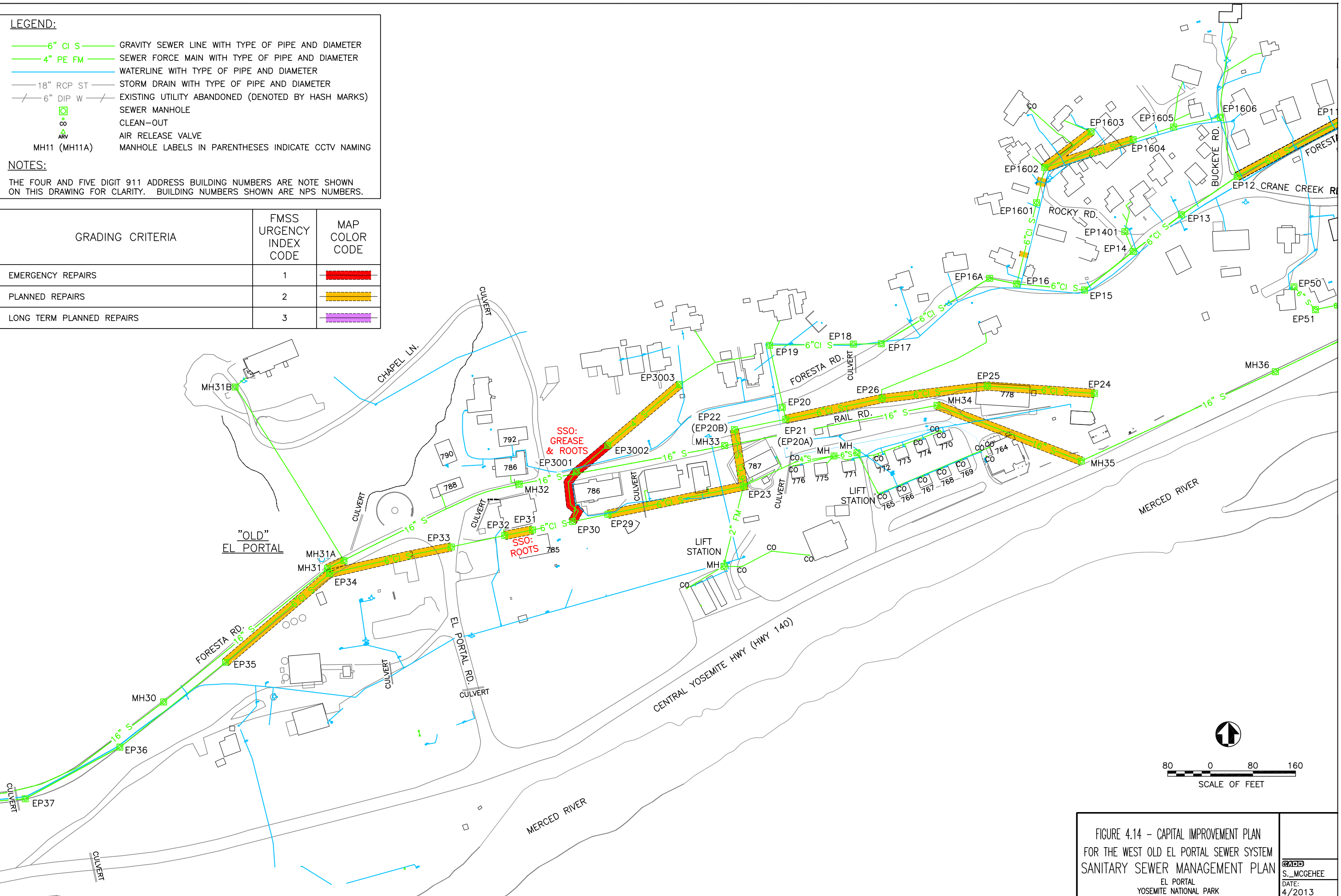

FIGURE 4.14 - CAPITAL IMPROVEMENT PLAN FOR THE WEST OLD EL PORTAL SEWER SYSTEM
 SANITARY SEWER MANAGEMENT PLAN
 EL PORTAL
 YOSEMITE NATIONAL PARK

GADD
 S._MCGEEHEE
 DATE:
 4/2013

LEGEND:

- 6" CI S — GRAVITY SEWER LINE WITH TYPE OF PIPE AND DIAMETER
- 4" PE FM — SEWER FORCE MAIN WITH TYPE OF PIPE AND DIAMETER
- WATERLINE WITH TYPE OF PIPE AND DIAMETER
- 18" RCP ST — STORM DRAIN WITH TYPE OF PIPE AND DIAMETER
- - - 6" DIP W - - - EXISTING UTILITY ABANDONED (DENOTED BY HASH MARKS)
- SEWER MANHOLE
- CLEAN-OUT
- ▲ ARV AIR RELEASE VALVE
- MH11 (MH11A) MANHOLE LABELS IN PARENTHESES INDICATE CCTV NAMING

NOTES:

THE FOUR AND FIVE DIGIT 911 ADDRESS BUILDING NUMBERS ARE NOTE SHOWN ON THIS DRAWING FOR CLARITY. BUILDING NUMBERS SHOWN ARE NPS NUMBERS.

GRADING CRITERIA	FMS URGENCY INDEX CODE	MAP COLOR CODE
EMERGENCY REPAIRS	1	
PLANNED REPAIRS	2	
LONG TERM PLANNED REPAIRS	3	

4/2/13 17:05 SETH_R18 G:\CLIENTS\NPS\10-0380C\YOSE\PMIS\DRAWINGS\CIV\F4-2-4.16_SITE_EL_POD.DWG_XREFS: G:\CLIENTS\NPS\10-0380C\YOSE\PMIS\DRAWINGS\BASES\EL PORTAL.DWG; G:\CLIENTS\NPS\10-0380C\YOSE\PMIS\DRAWINGS\BASES\EP_UTIL.DWG;

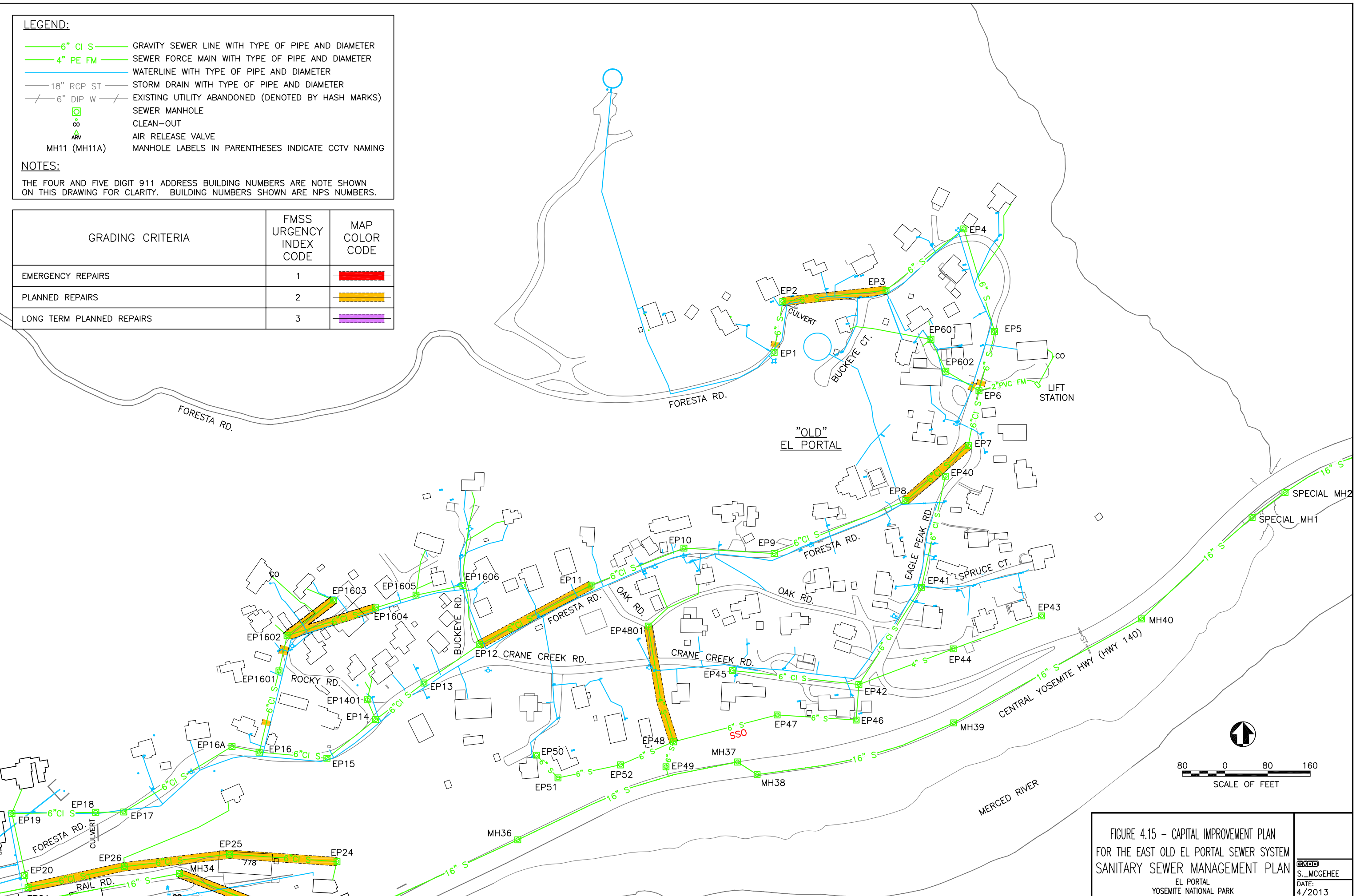

FIGURE 4.15 - CAPITAL IMPROVEMENT PLAN FOR THE EAST OLD EL PORTAL SEWER SYSTEM
SANITARY SEWER MANAGEMENT PLAN
 EL PORTAL
 YOSEMITE NATIONAL PARK

CAAD
 S._MCGEEHEE
 DATE:
 4/2013

4/2/13 17:05 SETH R18 G:\CLIENTS\NPS\10-0380C\YOSE\PMIS\DRAWINGS\CIV\F4-2-4.16_SITE_EL_PODWG.XREFS G:\CLIENTS\NPS\10-0380C\YOSE\PMIS\DRAWINGS\BASES\EP-UTILS.DWG; G:\CLIENTS\NPS\10-0380C\YOSE\PMIS\DRAWINGS\BASES\ELPORTAL.DWG; G:\CLIENTS\NPS\10-0380C\YOSE\PMIS\DRAWINGS\BASES\EP-UTILS.DWG;

LEGEND:

- 6" CI S — GRAVITY SEWER LINE WITH TYPE OF PIPE AND DIAMETER
- 4" PE FM — SEWER FORCE MAIN WITH TYPE OF PIPE AND DIAMETER
- — WATERLINE WITH TYPE OF PIPE AND DIAMETER
- 18" RCP ST — STORM DRAIN WITH TYPE OF PIPE AND DIAMETER
- / 6" DIP W / — EXISTING UTILITY ABANDONED (DENOTED BY HASH MARKS)
- SEWER MANHOLE
- CLEAN-OUT
- ▲ — AIR RELEASE VALVE
- MH11 (MH11A) — MANHOLE LABELS IN PARENTHESES INDICATE CCTV NAMING

NOTES:

THE FOUR AND FIVE DIGIT 911 ADDRESS BUILDING NUMBERS ARE NOTE SHOWN ON THIS DRAWING FOR CLARITY. BUILDING NUMBERS SHOWN ARE NPS NUMBERS.

GRADING CRITERIA	FMSS URGENCY INDEX CODE	MAP COLOR CODE
EMERGENCY REPAIRS	1	
PLANNED REPAIRS	2	
LONG TERM PLANNED REPAIRS	3	

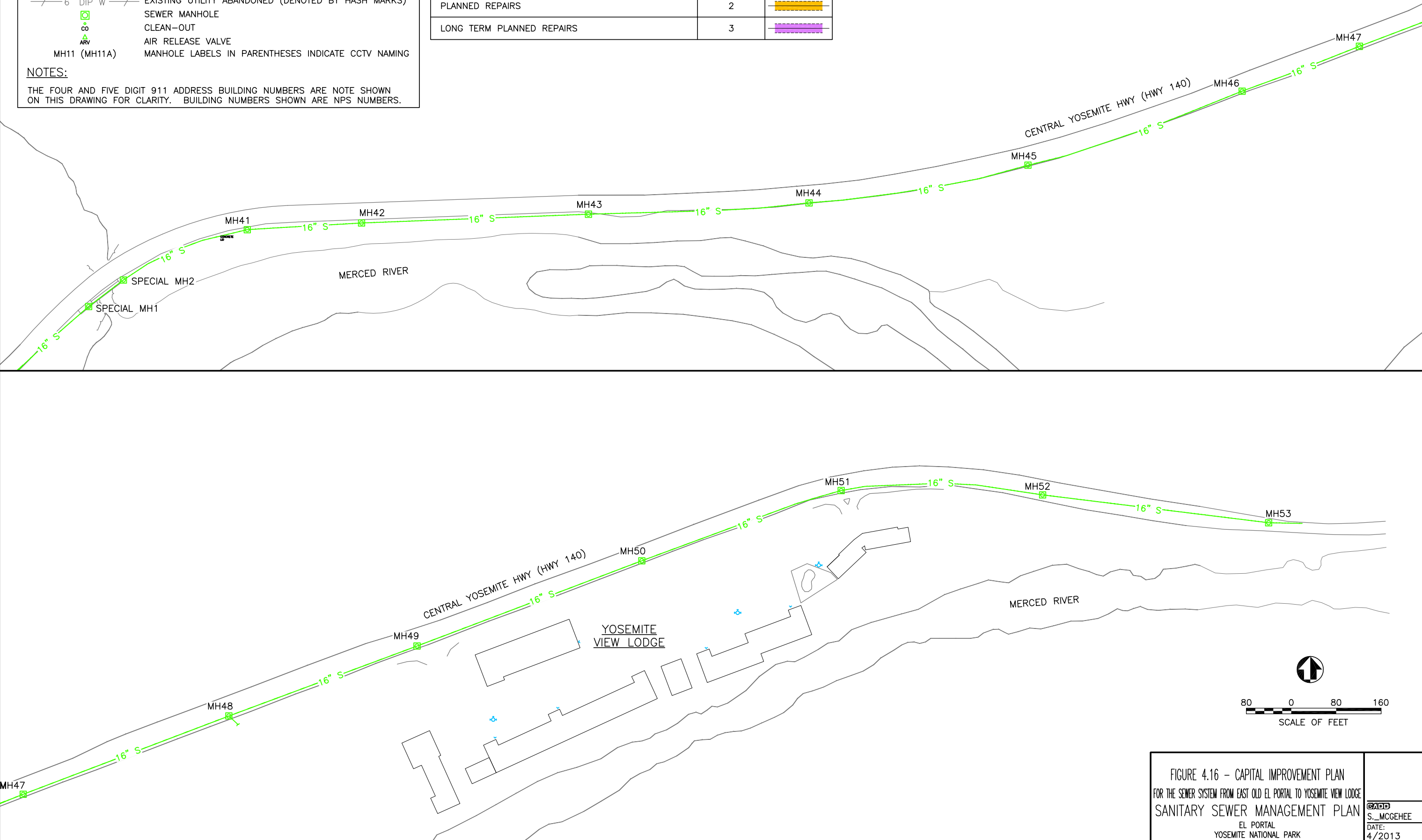

FIGURE 4.16 - CAPITAL IMPROVEMENT PLAN
 FOR THE SEWER SYSTEM FROM EAST OLD EL PORTAL TO YOSEMITE VIEW LODGE
 SANITARY SEWER MANAGEMENT PLAN
 EL PORTAL
 YOSEMITE NATIONAL PARK

GADD
 S._MCGEEHEE
 DATE:
 4/2013

YOSEMITE NATIONAL PARK UTILITIES BRANCH

SEWER SYSTEM MANAGEMENT PLAN EL PORTAL SANITARY SEWER SYSTEM (CS 5SSO10735)

List of Exhibits

- Exhibit 4.1 – California Waste Discharge Requirements Order R5-2008-0060
- Exhibit 4.2 – Manhole Inspection Form
- Exhibit 4.3 – Template for CCTV Data Reporting: Including Codes and Terms & PACP
Ranking / Severity of Defect
- Exhibit 4.4 – NPS Actions following Observations of Sewer Cleaning
- Exhibit 4.5 – Sewer Cleaning Report
- Exhibit 4.6 – Pump Checklist (Refer to Section 4.3.3)

EXHIBIT 4.1

El Portal – R5-2008-0060

(http://www.waterboards.ca.gov/centralvalley/board_decisions/adopted_orders/mariposa/r5-2008-0060.pdf)

EXHIBIT 4.2

MANHOLE INSPECTION FORM

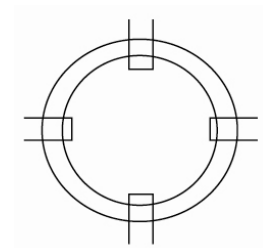
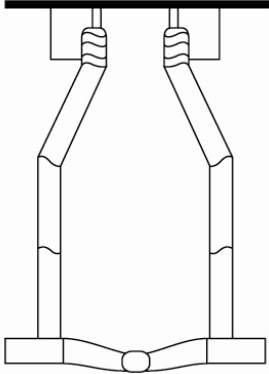

Inspection Date _____
 Inspector _____
 MH# _____ MH Depth _____
 Street Name _____
 Nearest Address _____
 GPS _____
 GPS _____

Overflow/Diversion Lines Present?
 Yes
 No

I. MANHOLE INITIAL INSPECTION

A - Location

- 1 Roadway
- 2 Gutter
- 3 Paved Alley
- 4 Unpaved Alley
- 5 Easement
- 6 Other _____

B - Manhole Cover

- 1 Serviceable
- 2 Damaged
- 3 Missing
- 4 Loose
- 5 Sealed
- 6 Other _____

C - Ring and Frame

- 1 Serviceable
- 2 Loose
- 3 Displaced
- 4 Missing Grout
- 5 Raise
- 6 Lower

D - Manhole Material

- 1 Brick
- 2 Concrete

E - Manhole Cover Size

- 1 24"
- 2 30"

F - Manhole Barrel Size

- 1 48"
- 2 60"

II. STRUCTURAL INSPECTION

A - Rungs

- 1 Serviceable
- 2 Unsafe
- 3 Missing (No)
- 4 Corroded
- 5 No rungs

B - Cone

- 1 Serviceable
- 2 Cracked/Broken
- 3 Corroded
- 4 Misaligned
- 5 Infiltration
- 6 Roots at joints

C - Riser

- 1 Serviceable
- 2 Cracked/Broken
- 3 Corroded
- 4 Misaligned
- 5 Infiltration
- 6 Roots at joints

D - Shelf

- 1 Serviceable
- 2 Cracked/Broken
- 3 Dirty
- 4 Corroded
- 5 Bad Base Joint

E - Channel

- 1 Serviceable
- 2 Obstructed
- 3 Corroded
- 4 Bad Pipe Joint(s)
- 5 Silt/Debris
- 6 Poor Structural Condition

III. HYDRAULIC INSPECTION

A - Surcharge Indications

- 1 Grease/Debris on Sides/Rungs
- 2 Grease/Debris on Shelf

B - Clarity of Flow

- 1 Turbid Sewage Appearance
- 2 Clear Water Appearance

C - Flow Conditions

- 1 Steady
- 2 Pulsing
- 3 Turbulent
- 4 Surcharging
- 5 Sluggish

Recommendations (Note I, II, or III and letter and number):

General Observations

EXHIBIT 4.3
Template for CCTV Data Reporting

Line Item	Location or Pipe Segment ¹			Defect Description and Severity ²		Defect Scoring ³		Final Priority ⁴		Remarks
	Beginning MH	Ending MH	NPS Asset No.	Structural	O&M	Structural	O&M	Structural	O&M	
1										
2										
3										
4										
5										
<p>Note 1: Refer to mapping and NPS Asset Inventory Note 2: Refer to Codes and Term & PACP Ranking / Severity of Defect included with this exhibit. Construction defects will be considered as structural defects in this priority rating scheme. Note 3: Scoring is the total sum of each defect found in the pipe segment multiplied by the severity of each defect grade number Note 4: Highest number is highest priority.</p> <p>Sources: Innovative Internal Camera Inspection and Data Management for Effective Condition Assessment of Collection Systems, EPA/600/R-10/082, April 2010, Office of Research and Development. , US Environmental Protection Agency, Cincinnati, Ohio 45268 National Association of Sewer Service Companies (NASSCO). 2001. Pipeline Assessment and Certification Program (PACP) Reference Manual. (NASSCO).</p>										

Codes and Terms¹ for Internal Sewer Piping Inspections Using CCTV²

Description or Terms for Structural Pipe Degradation and Defects

- C: Cracks: note length and whether circumferential, longitudinal, spiral, multiple
- F: Fractures: note length, and whether circumferential, longitudinal, spiral, multiple
- B: Broken pipe: describe length
- H: Hole in pipe: describe hole diameter
- D: Minor: 0 – 25% change and Severe is more than 25% change
- X: Collapse: describe location (e.g., pipe, manhole, drainage inlet, junction box)
- J: Joint: open or offset with severity of moderate or severe
- S: Surface Damage: Roughness increased, aggregate visible, aggregate projecting, aggregate missing, reinforcement visible, reinforcement projecting, reinforcement corrosion, pipe corrosion
- LF: Lining Failure: detached, hole, blistered, wrinkled
- WF: Weld Failure: plastic or metal pipe, circumferential, longitudinal, spiral, multiple
- PR: Point Repair: patched, localized liner, replaced
- BW: Brick or Masonry Work: brick displaced, missing, missing mortar, missing grout

Description or Terms for Construction Features and Possible Defects

- T: Tap: requires special fitting tool for repair
- IS: Intruding Seal: Exposed or hanging gaskets or seals
- L: Line: piping misaligned and describe as necessary (e.g., light pipe dips < 1 inch, moderate pipe dips 1 inch to ¼ pipe diameter, major pipe dips are greater than ¼ pipe diameter; light pipe dip lengths are less than 10 feet or ½ pipe length, moderate pipe dip lengths ½ to 2 pipe lengths, and major pipe dip lengths are greater than 2 pipe lengths)
- SC: Slope Change: pipe slope changes, describe as necessary
- MC: Material Change: pipe materials change, describe as necessary
- A: Access Point: describe as necessary (e.g., manhole, street drainage inlet or curb opening with single or double grates, yard or lawn drainage inlet, etc.)

Codes and Terms¹ for Internal Sewer Piping Inspections Using CCTV² (Continued)

Description or Terms for Operations and Maintenance Concerns or Defects

- D: Deposits: attached or settled and describe blockage (i.e., light is <20%, moderate is 20% to 40% and major is > 40%)
- R: Roots: describe blockage (i.e., light to medium < 50%, heavy > 50% to 90%, Severe 90% to 100%)
- I: Infiltration: Inactive with wall stains and mineral deposits. Active with weep, drip, lightly flow stream, and heavily flowing stream
- OB: Obstacles & Obstruction: light is < 20% obstruction, moderate obstruction is 20% to 40%, heavy obstruction is 40% to 90%, and blocked is 90% to 100%
- V: Vermin: describe as necessary

Other Miscellaneous Terms Indicating Sewer System Problems

- M: Miscellaneous: camera underwater (CW) reflecting blockage or poor pipe alignment

Note 1: Terms are not all inclusive; therefore, add other terms as discovered

Note 2: Sources:

- Innovative Internal Camera Inspection and Data Management for Effective Condition Assessment of Collection Systems, EPA/600/R-10/082, April 2010, Office of Research and Development. , US Environmental Protection Agency, Cincinnati, Ohio 45268
- National Association of Sewer Service Companies (NASSCO). 2001. Pipeline Assessment and Certification Program (PACP) Reference Manual. (NASSCO)

Ranking or Severity of Pipe Segment Condition¹

Ranking or Severity of Defect	Expected Condition of Defect	NPS Action & Inspection Frequency
Grade 5	Pipe segment has failed or will likely fail within the next five years.	Immediate Repair As Soon As Possible
Grade 4	Pipe segment has severe defects with the risk of failure within the next five to ten years	High Inspect 2 to 6 years
Grade 3	Pipe segment has moderate defects. Deterioration may continue, but not for ten to twenty years	Medium Inspect within 5 to 10 years
Grade 2	Pipe segment has minor defects. Pipe is unlikely to fail for at least twenty years.	Low Inspect within 10 to 15 years
Grade 1	Pipe segment has minor defects whereas failure is unlikely in the foreseeable future	Not Required Inspect within 15 to 25 years

Note 1: Pipe grading per Pipeline Assessment Certification Program (PACP) developed by the National Association of Sewer Services Company (NASSCO).

Exhibit 4.4
Summary of NPS Actions Following Observations of Sewer Pipe Cleaning

Wastewater Contaminant Characteristics	Condition of Wastewater Rinseate Observed During Sewer Flushing/Cleaning ¹			
	Clear	Light	Moderate	Heavy
Debris and Grit	Observation Code: CL <ul style="list-style-type: none"> No observable debris or grit 	Observation Code: DL <ul style="list-style-type: none"> Minor amount of debris 15 minutes or less to clean 1 pass 	Observation Code: DM <ul style="list-style-type: none"> Less than 5 gallon of debris 15-30 minutes to clean 2-3 passes required Requires cleaning 2 or less per year Only fine grit 	Observation Code: DH <ul style="list-style-type: none"> More than 5 gallon of debris More than 30 minutes to clean More than 4 passes required Requires cleaning 4 times per year Operator concern for future stoppage
Grease	Observation Code: CL <ul style="list-style-type: none"> No observable grease 	Observation Code: GL <ul style="list-style-type: none"> Minor amounts of grease 15 minutes or less to clean 1 pass 	Observation Code: GM <ul style="list-style-type: none"> Small chunks/no "logs" 15-30 minutes to clean 2-3 passes required Requires cleaning 2 or less per year 	Observation Code: GH <ul style="list-style-type: none"> Big chunks/"logs" More than 30 minutes to clean More than 4 passes required Operator concern for future stoppage
Roots	Observation Code: CL <ul style="list-style-type: none"> No observable roots 	Observation Code: RL <ul style="list-style-type: none"> Minor amounts of roots 15 minutes or less to clean 1 pass 	Observation Code: RM <ul style="list-style-type: none"> Thin/stringy roots present No large "clumps" 15-30 minutes to clean 2-3 passes required 	Observation Code: RH <ul style="list-style-type: none"> Thick roots present Large "clumps" More than 30 minute to clean More than 4 passes required Operator concern for future stoppage
Other	Observation Code: CL <ul style="list-style-type: none"> No observable materials 	Observation Code: OL Specify material Minor amounts of material	Observation Code: OM <ul style="list-style-type: none"> Specify material Less than 5 gallons of material 	Observation Code: OH <ul style="list-style-type: none"> Specify material More than 5 gallons of material Operator concern for future stoppage
NPS Action	Decrease maintenance frequency to next lower frequency after 2 consecutive CL results (with supporting CCTV results)	Continue maintenance frequency	Increase maintenance frequency to next higher frequency	Increase maintenance frequency to next higher frequency

Note 1: Times shown are for typical manhole to manhole distance of 250 feet for small diameter sewers (6 and 8 inch diameter piping). Longer runs will require longer cleaning times. Judgment will need to be applied by the field crews for varying lengths and pipe diameters.

EXHIBIT 4.6
Pump Station Assessment Checklist

Facility Name: _____ Inspection Date: _____

Pump Station Identification: _____

Inspection Conducted By: _____

SSO History (during last five years): _____

Alarm History (during last five years): _____

Operating Problems History (during last five years): _____

Equipment Failures (during last five years): _____

Pending Work Orders: _____

No.	Inspection Element	Observations	Rehab Required YES - NO
1	Site Security		
	Fencing and Gates		
	Doors and Locks		
	External Lighting		
	Signage		
	Other		
2	Building/Structure		
	Wet Well		
	Dry Well		
	Control Room		
	Valve Vault		
	Lighting		
	Ventilation		
	Other		
3	Instrumentation & Controls		
	Control Panel		
	Flow Meter		
	Wet well Level Sensor		
	SCADA		
	Other Instrumentation		
4	Pumps & Motors		
	Lubrication		
	Motor Current		

No.	Inspection Element	Observations	Rehab Required YES - NO
	Vibration and Alignment		
	Seals		
	Insulation		
	Discharge Pressure		
	Shutoff Head or Pressure		
	Corrosion and Leakage		
	Drive Shaft		
	Other		
5	Valving & Piping		
	Valve Operation		
	Valve Condition		
	Pipe Condition		
	Other		
6	Electrical & Switch Gear		
	Transformers		
	Transfer Switches		
	Electrical Cabinets		
	Conduit and Wire-ways		
	Variable Frequency Drives		
	Emergency Generator Operation		
	Emergency Generator Maintenance	(check liquid levels)	
	Other		
7	Site Safety		
	Confined Spaces		
	Fall Protection		
	Handrails and Grating		
	Equipment Guards		
	Tag Out and Lock Out Equip		
	Eye Wash		
	Chemical Storage		
	Cranes		
	Hearing Protection		
	Other		
8	Service Utilities		
	Water		
	Sewer		
	Telephone		
	Telemetry		
	Electrical Power		
	Generator		
9	Other Pump Station Conditions		

YOSEMITE NATIONAL PARK UTILITIES BRANCH

SEWER SYSTEM MANAGEMENT PLAN EL PORTAL SANITARY SEWER SYSTEM (CS 5SSO10735)

5.0 DESIGN AND PERFORMANCE PROVISIONS

YOSEMITE NATIONAL PARK UTILITIES BRANCH

SEWER SYSTEM MANAGEMENT PLAN

EL PORTAL

SANITARY SEWER SYSTEM (CS 5SSO10735)

5.1 DESIGN STANDARDS

These Design Standards provide minimum standards for the design of the wastewater collection and pumping systems throughout Yosemite National Park to safely convey sewer flow to the wastewater treatment plants. These standards do not include specific requirements for on-site disposal systems utilizing individual septic tanks and disposal fields.

5.1.1 GRAVITY SEWER MAINS

- A. Pipe Material – All gravity sewer mains shall be constructed of one of the following pipe materials:
1. Polyvinyl Chloride (PVC) – PVC pipe shall be SDR 35 and shall conform to the requirements of ASTM D-3034. Joints for PVC pipe shall be elastomeric rubber gasket type.
 2. Polyvinyl Chloride (PVC) C-900 – PVC DR 18 pipe shall conform to the requirements of AWWA Standard C-900 for water class pipe.
 3. Ductile Iron – Class 52 cement-lined ductile iron pipe with a fused calcium aluminate cement mortar lining meeting ANSI/AWWA standards.
 4. High Density Polyethylene (HDPE) – Butt-fused joints and wall thickness of not less than DR 26.
- B. Alignment
1. Horizontal – Typically, all sewer mains should be designed in a straight-line between manholes. However, horizontal curvature using joint deflections between 1-5 degrees and longitudinal bending with a minimum radius per the requirements of the pipe manufacturer may be allowed by the Park. If horizontal curvature is allowed, only one horizontal curve between manholes is permitted.
 2. Vertical – All sewer mains shall be installed at a uniform slope between manholes. No vertical curves in sewer mains are allowed.

YOSEMITE NATIONAL PARK UTILITIES BRANCH

SEWER SYSTEM MANAGEMENT PLAN

EL PORTAL

SANITARY SEWER SYSTEM (CS 5SSO10735)

- a. Sewer mains shall be designed and constructed to provide a mean velocity of 2 feet per second when flowing ½ full at peak flow and shall meet or exceed the following minimum slopes:

Pipe Size (in)	Slope (% min)
6	1.00
8	0.40
10	0.28
12	0.22
15	0.15
18	0.22

- b. Steep Sewers – All steep sewers (20% or greater) shall have pipe anchors constructed in accordance with Standard Drawing No. 05-008. Flow velocities shall be limited to a maximum of 15 feet per second at the peak flow rate. In addition, the Park Project Manager may require a geotechnical soils report to address:
- General soils and bedrock conditions and any additional trench, bedding and backfill requirements.
 - Stability or instability of selected sewer alignment.
 - Potential groundwater problems and mitigation measures.

C. Cover – The minimum cover over top of pipe of all sewer mains shall be 3-feet.

D. Pipe Sizes – The minimum size of gravity sewer mains shall be 6-inches.

E. Trench – All sewer mains shall be constructed in accordance with the following requirements and Standard Drawing Nos. 05-001, 05-002, and 05-003.

- Width – The minimum width of trench shall be two (2) feet plus the pipe diameter.

YOSEMITE NATIONAL PARK UTILITIES BRANCH

SEWER SYSTEM MANAGEMENT PLAN

EL PORTAL

SANITARY SEWER SYSTEM (CS 5SSO10735)

2. Backfill and Bedding – Class II Aggregate Base shall conform to the State Standard Specifications. Minimum relative compaction shall be 95% (ASTM-D1557). If pavement having a structural section greater than 15" is cut, additional base material may be required by the Park Project Manager. Base shall be placed and compacted prior to placing of temporary paving.
 3. Selective Backfill – Intermediate backfill shall be Class II Aggregate Base. Suitable native or imported granular material may be used if allowed by Park Project Manager. Relative compaction shall be at least 90% (ASTM-D1557).
- F. Separation – All sewer mains shall be installed to the criteria for the separation of water mains and sanitary sewers set forth in the California Water Works Standards contained in the California Administrative Code. Any deviations from such requirements must be approved by the National Park Service.
- G. Utility Crossings – Long skew crossings under or over existing or proposed utilities shall be avoided. Sewers shall cross utilities as close to perpendicular as possible and in no case less than 45 degrees.
- H. Locator Tape – Metallic locator tape shall be installed 8"-10" below the finished surface for all sewer mains.
- I. Tracer Wire – Tracer wire shall be installed on all gravity sewer mains with the following requirements:
1. Tracer wire shall be 10 AWG minimum.
 2. THW, THHW, TW or THWN wet location insulation.
 3. Taped to the top of the pipe at ten (10) foot intervals and all bends.
 4. If spliced, splices shall incorporate a U.L. listed underground splice kit.
 5. Tracer wire shall be installed along the pipeline and outside the manhole with wire entering the manhole at the grade ring joint. The wire shall terminate with a minimum of three (3) feet of a coiled wire inside the manholes at each end of the sewer. Wire shall be neatly rolled with ends securely taped and situated such as to not interfere with any maintenance or access to manholes.

YOSEMITE NATIONAL PARK UTILITIES BRANCH

SEWER SYSTEM MANAGEMENT PLAN

EL PORTAL

SANITARY SEWER SYSTEM (CS 5SSO10735)

5.1.2 MANHOLES

- A. Locations – Manholes shall be required on all sewer mains with a change of grade, change in pipe size, at the intersection of mains, and/or at the terminus of dead-end sewers. Manholes shall not be located within 10 feet of any structure.
- B. Spacing – The maximum spacing of manholes shall be 400 feet. However, the spacing may be reduced by the Park for installations where the slope exceeds 8%.
- C. Size – Standard manholes shall be 48-inch inside diameter. Inside diameter of manhole shall be 5 feet when depth exceeds 15 feet.
- D. The minimum drop of elevation through the manhole shall be 0.20 feet.
- E. Manhole frames and covers shall be heavy-duty cast-iron with a 30 inch frame and 24 inch diameter with lettering “SANITARY SEWER” molded into top of cover. Cover shall have four (4) pick holes of 1-inch diameter.
- F. All manholes shall be watertight. Seal all external joints with 12-inch EZ-Wrap or equivalent per manufacturer's requirements.
- G. All manholes shall have eccentric cones with the vertical wall on the upstream side of manhole, rotated 45 degrees.
- H. Drop manholes – Drop manhole installations are required when the difference in elevation between the influent and effluent sewer pipe is greater than 2 feet. While not encouraged, drop manholes may be required because of a physical restraint. They may not be used to avoid extra depth trenching unless unusual circumstances exist. Upstream slope changes should be used to avoid the need for a drop manhole. Drop manholes shall be constructed as shown on Standard Drawing No. 05-006.
- I. The construction of drop manholes and connections to existing manholes shall be inspected by the Park prior to backfilling.

YOSEMITE NATIONAL PARK UTILITIES BRANCH

SEWER SYSTEM MANAGEMENT PLAN

EL PORTAL

SANITARY SEWER SYSTEM (CS 5SSO10735)

- J. Where work involves tying into an existing NPS manhole, the following note in bold lettering shall be included on the construction plans:

Note: Before entering this manhole, contractor shall comply with all requirements of the Division of Industrial Safety-Construction safety orders Title 8, Article 108, "Confined Spaces." Contact USRO staff before entering.

5.1.3 SERVICE LATERALS

- A. Pipe Material - All service laterals shall be constructed of one of the following pipe materials:
1. Polyvinyl Chloride (PVC) – PVC pipe shall be SDR 35 and shall conform to the requirements of ASTM D-3034. Joints for PVC pipe shall be elastomeric rubber gasket type.
 2. Polyvinyl Chloride (PVC) C-900 – PVC DR 18 pipe shall conform to the requirements of AWWA Standard C-900 for water class pipe.
 3. Ductile Iron – Class 52 cement-lined ductile iron pipe with a fused calcium aluminate cement mortar lining meeting ANSI/AWWA standards.
 4. High Density Polyethylene (HDPE) – Butt-fused joints and wall thickness of not less than DR 26.
- B. The minimum size of sewer services shall be 4-inches.
- C. The minimum slope of sewer services shall be 2% for 4-inch laterals and 1% for 6-inch laterals.
- D. Cleanouts shall be spaced at one every 100 feet of service line with a cleanout located within five (5) feet of the structure outside the building foundation and at all angle points per Section H, Bends, item one.
- E. Services shall be connected to the sewer mains by a service wye or tee.
- F. Services connected to existing sewer mains shall be with a Romac CB saddle or equivalent. No "inserta tees" are allowed.

YOSEMITE NATIONAL PARK UTILITIES BRANCH

SEWER SYSTEM MANAGEMENT PLAN

EL PORTAL

SANITARY SEWER SYSTEM (CS 5SSO10735)

- G. All services shall be directly connected to the sewer main unless located at the manhole on a dead end sewer and approved by the Park. Service connections in manholes shall be limited to a total of two with the manhole base channeled for the services and angled downstream to the outlet.
- H. Bends – Where bends are necessary in the construction of the sewer laterals, the following requirements shall be met:
1. Cleanouts shall be placed within five (5) feet of all bends of 45 degrees.
 2. Bends shall not exceed 45 degrees.
- I. Locator Tape – Metallic locator tape shall be installed 8"-10" below the finished surface for all sewer laterals.
- J. Tracer wire shall be installed on all sewer services from the foundation cleanout to a splice with the tracer wire on the sewer main meeting the following requirements:
1. Tracer wire shall be 10 AWG minimum.
 2. THW, THHW, TW or THWN wet location insulation.
 3. Taped to the top of the pipe at ten (10) foot intervals and all bends.
- K. If spliced, splices shall incorporate a U.L. listed underground splice kit.

5.1.4 PRESSURE SEWER

- A. Pipe Material – All pressure sewer pipe shall be constructed of one of the following:
1. Ductile Iron – Class 52 cement-lined ductile iron pipe with a fused calcium aluminate cement mortar lining meeting ANSI/AWWA standards.
 2. Polyvinyl Chloride (PVC) C-900 – PVC, DR 18 pipe shall conform to the requirements of AWWA Standard C-900 for water class pipe.
 3. High Density Polyethylene (HDPE) – Butt-fused joints and wall thickness of not less than DR 17.
- B. Pipe Size – The minimum pipe size of pressure sewer piping shall be 3 inches.

YOSEMITE NATIONAL PARK UTILITIES BRANCH

SEWER SYSTEM MANAGEMENT PLAN

EL PORTAL

SANITARY SEWER SYSTEM (CS 5SSO10735)

- C. Cover – The minimum cover over the pressure sewer piping shall be 3 feet over top of pipe.
- D. Cleanouts – For pressure sewer mains over 500 feet in length, pressure sewer cleanouts shall be installed at a spacing of 500 feet in accordance with Standard Drawing No. 05-009.
- E. Fittings – All fittings for PVC pressure sewer mains shall be mechanical joint ductile iron class 250 minimum.
- F. Tracer wire shall be installed on all pressure sewer mains with the following requirements:
 - 1. Tracer wire shall be 10 AWG minimum.
 - 2. THW, THHW, TW or THWN wet location insulation.
 - 3. Taped to the top of the pipe at ten (10) foot intervals and all bends.
 - 4. If spliced, splices shall incorporate a U.L. listed underground splice kit.
- G. Locator Tape – Metallic locator tape shall be installed 8"-10" below the finished surface for all pressure sewer mains.
- H. Air Release Valves – All high points of the pressure sewer main shall have a combination air valve installed, Val-Matic or approved equivalent as shown in Standard Drawing No. 05-011.

5.1.5 LIFT STATION

The following sewage lift station specifications provide minimum design requirements for proposed lift stations in the Yosemite National Park (Park). The intent of these specifications is to establish minimum criteria for lift stations and upgrades. Standardizing lift stations will reduce maintenance and increase operational efficiencies over the entire system. Any variation from these specifications will require approval by the Park.

- A. Park Review and Acceptance – The lift station shall be constructed in accordance with Standard Drawing No. 05-012. The Project Manager shall approve the selected sanitary sewer lift station mechanical components,

YOSEMITE NATIONAL PARK UTILITIES BRANCH

SEWER SYSTEM MANAGEMENT PLAN

EL PORTAL

SANITARY SEWER SYSTEM (CS 5SSO10735)

electrical components, and construction materials used in the proposed lift station.

- B. Lift stations should be designed to remain operational during the 25-year flood.
- C. Buoyancy of lift stations shall be considered for areas of high groundwater.
- D. The station design flow shall be based upon the Peak Hourly Flow.
- E. Wet Well – All wet wells shall be designed to meet the following requirements.
 - 1. Wet wells shall have a minimum diameter of 72” and be constructed of precast concrete or Park approved equivalent.
 - 2. Wet well volume shall be determined based upon the following criteria:
 - a. Minimum design criteria as defined by the Park.
 - b. Current service area with consideration given to areas of potential expansion, specific uses, potential vendor uses, and other factors effecting wastewater volumes.
 - c. Volume shall be designed based upon peak flows with consideration given to peak hour and peak day.
 - d. Filling time shall not exceed 30 minutes unless lift station is designed to provide flow equalization.
 - 3. The wet well floor shall be provided with slope fillets (1:1 slope) along the edge to avoid solids accumulation.
 - 4. The exterior of the wet well joints shall be wrapped with 12-inch EZ-Wrap or equivalent per the manufacturer’s requirements.
 - 5. The interior of the wet well shall have an epoxy resin coating. The coating shall be a hydrocarbon resin modified epoxy polyamide.
 - 6. Wet well shall have an independent access cover over the pump chamber. The cover shall be one size larger than required by the pumps, but not less than 36” x 48”. The access hatch shall be aluminum with 316 stainless steel hardware and flush mounted. The access cover shall be traffic rated. The access cover shall be Halliday, Bilco or approved equivalent.
 - 7. Wet wells shall include a 4-inch pre-fabricated vent with a carbon filter.
 - 8. No valves shall be located in the wet well.

YOSEMITE NATIONAL PARK UTILITIES BRANCH

SEWER SYSTEM MANAGEMENT PLAN

EL PORTAL

SANITARY SEWER SYSTEM (CS 5SSO10735)

F. Valve Vault:

1. A valve vault is required to house the valving and pipe necessary for a minimum of a duplex pump system with surface bypass pumping capabilities.
2. Vault shall meet all regulating agencies' requirements.
3. Valve vault shall have a 4-inch floor drain to discharge accumulated water back to the wet well. The drain line shall include a "P" trap between the vault and the wet well and have a PVC check valve in the wet well.
4. The minimum dry well height shall be no less than 78 inches.
5. The access cover for the valve vault shall have dimensions not less than 36" x 48". The access cover shall be made of aluminum and be lockable. The cover shall be traffic rated and located to allow clear vertical access to camlock and all valve operators.

G. Sewer Lift Pumps:

1. As a minimum, the station shall be sized for a duplex pumping system.
2. Pumps shall have capacity that if the largest pump is out of service the remaining pump(s) will have capacity to handle the design flow.
3. Lift Pumps shall be designed for minimum solids handling capacity of 3".
4. Lift Pumps shall be ABS or Park approved equivalent.
5. Stainless steel guide rails with a minimum diameter of 2" shall be provided. Two rails shall be provided for each pump.
6. Stainless steel strand cable shall be provided for each pump. All fasteners for the hoisting cable and pump guide shall be stainless steel including all anchor bolts and nuts.
7. Stainless steel bolt packs with full face gaskets shall be provided inside the wet well.
8. Pumps shall be explosion proof.
9. Variable Frequency Drives (VFD) shall be provided with an appropriately sized active harmonic filter based on specific operational considerations. All pumps that do not have VFD's shall have soft starters for all pumps.

YOSEMITE NATIONAL PARK UTILITIES BRANCH

SEWER SYSTEM MANAGEMENT PLAN

EL PORTAL

SANITARY SEWER SYSTEM (CS 5SSO10735)

H. Station Piping and Valves:

1. Piping into and out of the lift station and valve vault shall be ductile iron for a minimum of 10 feet outside the structure.
2. Check valves shall be resilient ball valves or resilient swing check valves. Isolation valves shall be 1/4 turn resilient wedge plug valves, Mueller or equivalent approved by Park.
3. Check valves shall be located between the shutoff valve and the pump. Check valves shall conform to AWWA C508 and shall be manufactured from gray cast iron meeting or exceeding ASTM Class 30. Check valve shall be designed to permit clear waterway opening with the ball remaining out of the waterway during operation allowing the use of pipeline cleaning apparatus if necessary. A cleanout port shall be provided to permit access to the valve interior without having to remove the check valve from the pipeline. Fasteners shall be stainless steel and ball shall be hollow iron with natural rubber cover.
4. A cam lock fitting and valve shall be provided to allow bypass pumping into discharge during power losses.

I. Controls:

1. Control panel shall have a dead front enclosure.
2. Submerged pressure transducers suited for sewage supported with removable stainless steel cable system.
3. Programmable level control with alternating or fixed relays.
4. Hand, Off, and Auto switches shall be provided for each pump.
5. Elapsed time meters for each pump.
6. Accessible junction box above-ground with removable seal offs located on all cables entering the wet wells.
7. Manual transfer switch with generator receptacle. Coordinate with Park for type and location.
8. 500 watt heater with thermostat in panel.
9. Seal fail indication on all pumps.
10. High Level / Low Level alarm light with manual reset.
11. Outside alarm beacon illuminated when above alarms occur.

YOSEMITE NATIONAL PARK UTILITIES BRANCH

SEWER SYSTEM MANAGEMENT PLAN

EL PORTAL

SANITARY SEWER SYSTEM (CS 5SSO10735)

12. U.L. listed control panel by same manufacturer as pumps with full electronic read-out.
13. Gasketed cover on outer door.
14. Laminated schematic on inside of front door with panel serial number.
15. Night light for panel repair at site.
16. Lift station shall be remote radio and SCADA system control compatible.

J. Spare Parts:

1. 1 each spare pump and motor.
2. 5 each spare fuses of each size.
3. 1 each spare relay of each size.
4. 1 each spare transducer with cable.

K. Local Service & Warranty:

1. 5 year pro-rated warranty on pumps and 1 year on control panel.
2. Local factory authorized warranty repair facility within 100 miles of station location.

YOSEMITE NATIONAL PARK UTILITIES BRANCH

SEWER SYSTEM MANAGEMENT PLAN

EL PORTAL

SANITARY SEWER SYSTEM (CS 5SSO10735)

5.2 STANDARD DRAWINGS

The following standard drawings are included in Exhibit 5.1.

- No. 05-001 – Trench Detail Single Pipe Traffic Area
- No. 05-002 – Trench Detail Single Pipe Non-Traffic Area
- No. 05-003 – Trench Notes
- No. 05-004 – Standard Manhole
- No. 05-005 – Standard Shallow Manhole
- No. 05-006 – Drop Manhole
- No. 05-007 – Manhole Collar
- No. 05-008 – Pipe Slope Anchor
- No. 05-009 – Pressure Sewer Clean-Out In-Line
- No. 05-010 – Standard 4" Traffic Rated Clean-Out
- No. 05-011 – Combination Air Release/Vacuum Valve
- No. 05-012 – Lift Station

5.3 CONSTRUCTION SPECIFICATIONS

The following construction specifications are included in Exhibit 5.2.

- SECTION 02 25 00 – Wastewater Combination Air Valve
- SECTION 02 32 00 – Utility Trenching & Backfilling
- SECTION 02 32 10 – Utility Line Marking
- SECTION 02 40 10 – Sanitary Sewer Pipe
- SECTION 02 50 10 – Testing of Sewer Force Mains & Appurtenances
- SECTION 02 51 50 – Manhole Structures
- SECTION 02 53 10 – Sewer Line Cleaning
- SECTION 02 53 30 – Manhole Cleaning & Inspection
- SECTION 02 53 40 – Closed Circuit Television (CCTV) Inspection
- SECTION 11 31 10 – Wastewater Lift Station
- SECTION 15 16 00 – Pumps

EXHIBIT 5.1
STANDARD DRAWINGS

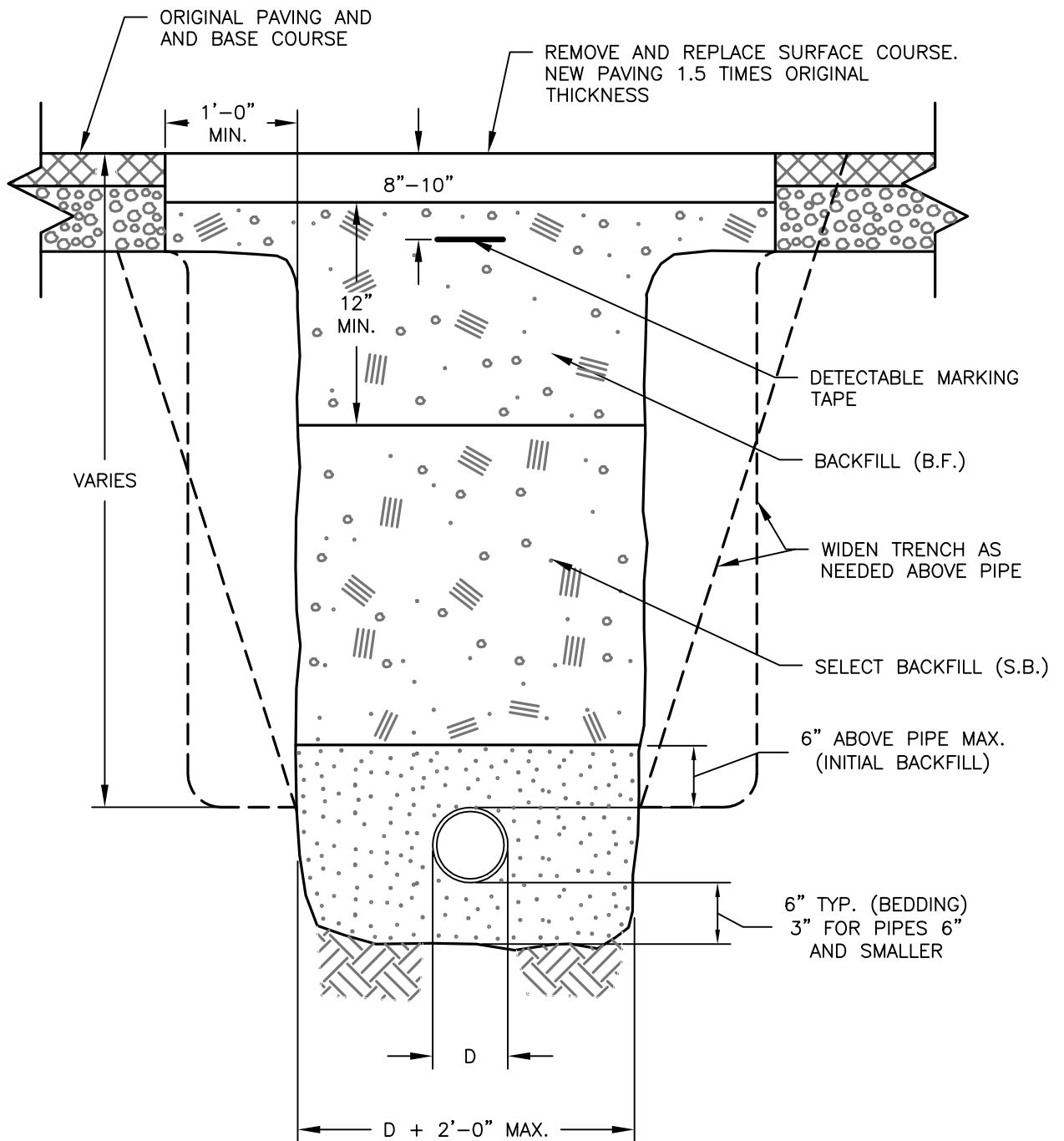

YOSE STANDARDS
FOR
SANITARY SEWER
CONSTRUCTION

TRENCH DETAIL SINGLE PIPE
TRAFFIC AREA
YOSEMITE NATIONAL PARK
MAY 2012

STANDARD DRAWING
NO.

05-001

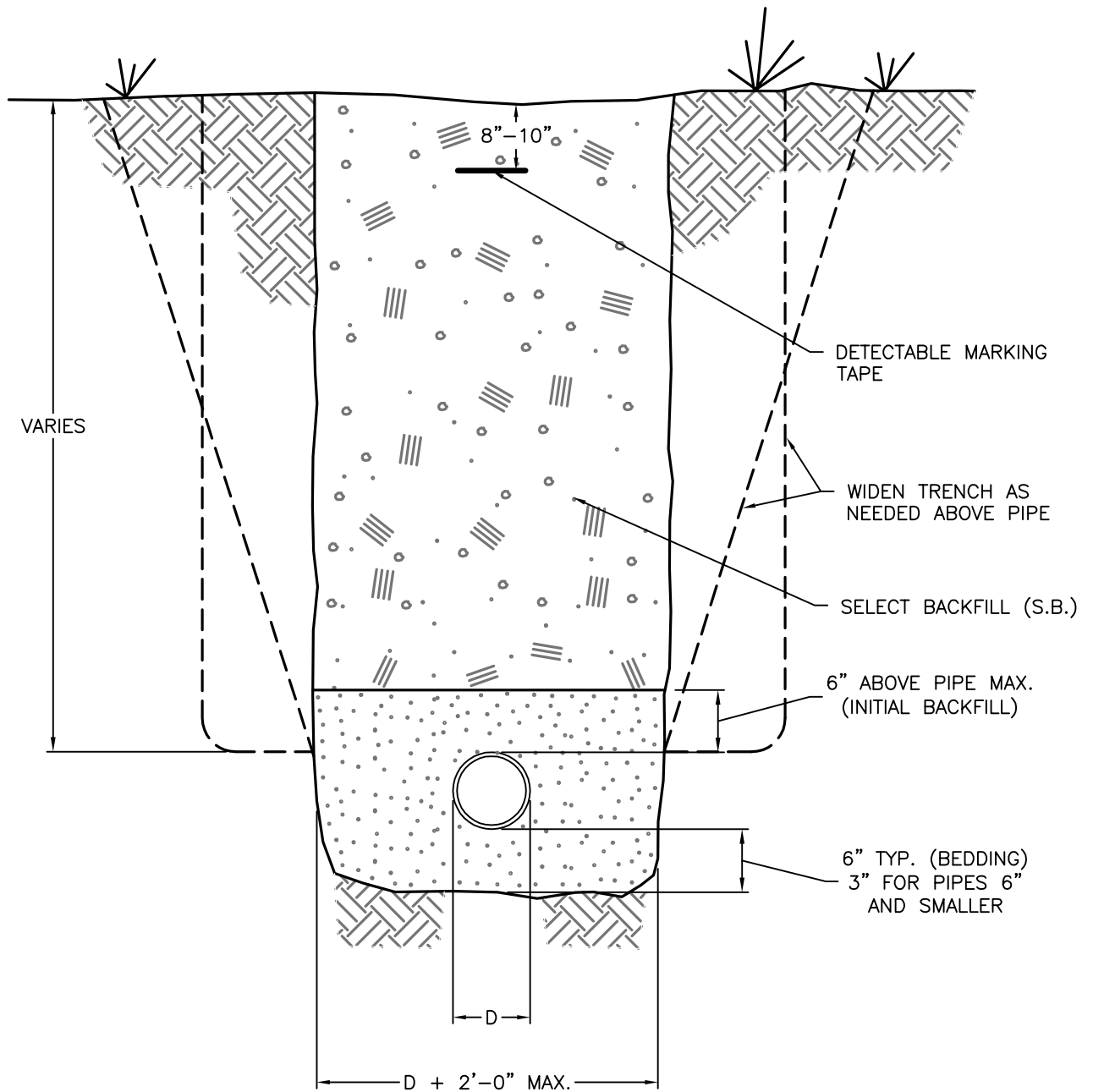

YOSE STANDARDS
FOR
SANITARY SEWER
CONSTRUCTION

TRENCH DETAIL SINGLE PIPE
NON-TRAFFIC AREA
YOSEMITE NATIONAL PARK
MAY 2012

STANDARD DRAWING
NO.

05-002

MATERIAL AND COMPACTION REQUIREMENT FOR TRENCH BACKFILL

1. B.F. AND BEDDING: CLASS II AGGREGATE BASE SHALL CONFORM TO THE STATE STANDARD SPECIFICATIONS. MINIMUM RELATIVE COMPACTION SHALL BE 95%. IF PAVEMENT HAVING A STRUCTURAL SECTION GREATER THAN 15" IS CUT, ADDITIONAL BASE MATERIAL MAY BE REQUIRED BY THE CONTRACTING OFFICER. BASE SHALL BE PLACED AND COMPACTED PRIOR TO PLACING OF TEMPORARY PAVING.
2. S.B.: INTERMEDIATE BACKFILL SHALL BE CLASS II AGGREGATE BASE. SUITABLE NATIVE OR IMPORTED GRANULAR MATERIAL MAY BE USED IF ALLOWED BY THE CONTRACTING OFFICER. RELATIVE COMPACTION SHALL BE AT LEAST 90%.
3. TESTING OF MATERIALS AND PERFORMANCE SHALL BE IN CONFORMANCE WITH THE METHODS STATED IN THE LATEST EDITION OF THE STATE OF CALIFORNIA, DEPARTMENT OF TRANSPORTATION, STANDARD SPECIFICATIONS, EXCEPT THAT RELATIVE COMPACTION MAY BE TESTED BY AASHTO METHOD T180, ASTM D-1557, OR TEST METHOD CALIF. 231 (NUCLEAR DENSOMETER).
4. PLACE AC IN 3" MAX. LIFTS, EXCEPT FINAL LIFT SHALL BE 2 1/2" MAX. ADDITIONAL THICKNESS AND LIFTS OF ASPHALT CONCRETE MAY BE REQUIRED TO MATCH EXISTING STRUCTURAL SECTION ON MAJOR ROADS.
5. "JETTING" OF BACKFILL MATERIAL IS NOT PERMITTED.
6. THE USE OF PEA GRAVEL (OR SIMILAR ROUNDED AGGREGATE), IS NOT PERMITTED.
7. TRENCH EDGES SHALL BE TRIMMED TO A NEAT LINE AS REQUIRED BY THE PARK PROJECT MANAGER. TRIMMING SHALL BE BY SAWCUT OR ROTARY GRINDER.
8. CONTRACTOR MUST SHORE ALL TRENCHES IN CONFORMANCE WITH OSHA AND STATE SAFETY STANDARDS.

4 FT. OR GREATER DEPTH,
PIPE DIA. ≤ 24 "

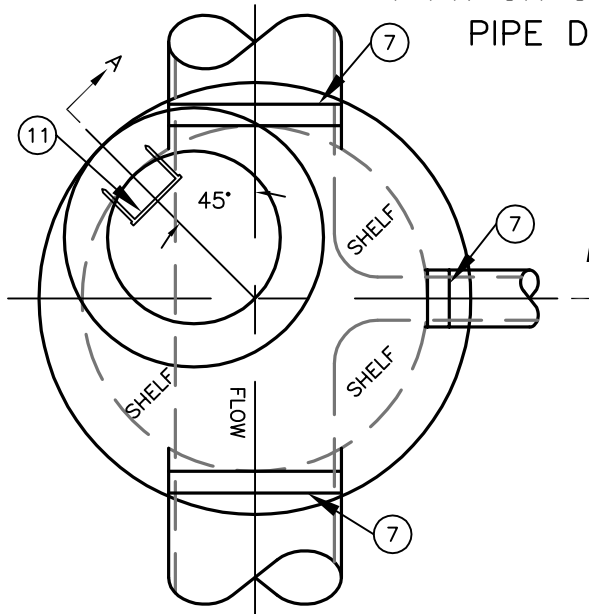

PLAN
N.T.S.

LEGEND:

- ① CONCRETE COLLAR IN PAVED STREET SECTIONS PER SD-
- ② GRADE RINGS GROUDED WATERTIGHT IN PLACE, NOT TO EXCEED 21" FROM FINISHED SURFACE TO TOP OF CONE.
- ③ PRECAST MONOLITHIC ECCENTRIC CONE SECTION. (REBAR NOT SHOWN).
- ④ RAMNEK OR APPROVED GASKETS ALL JOINTS.
- ⑤ PROPERLY ALIGN ALL INTERIOR JOINTS.
- ⑥ PRECAST CONCRETE MANHOLE-BARREL SECTION (REBAR NOT SHOWN).
- ⑦ PRECAST GASKETED HUB RING OR RUBBER GASKETED COLLAR-FLEXIBLE AND WATER TIGHT.
- ⑧ REPLACEMENT SURFACING TO MATCH FLUSH WITH EXISTING SURFACING (AC SHOWN).
- ⑨ FRAME TO BE GROUDED TO GRADE RINGS.
- ⑩ FRAME AND COVER.
- ⑪ MANHOLE STEPS.
- ⑫ CAST IN PLACE OR PRECAST MANHOLE BASE.
- ⑬ SEAL ALL EXTERNAL JOINTS WITH 12-INCH EZ-WRAP OR EQUIVALENT.

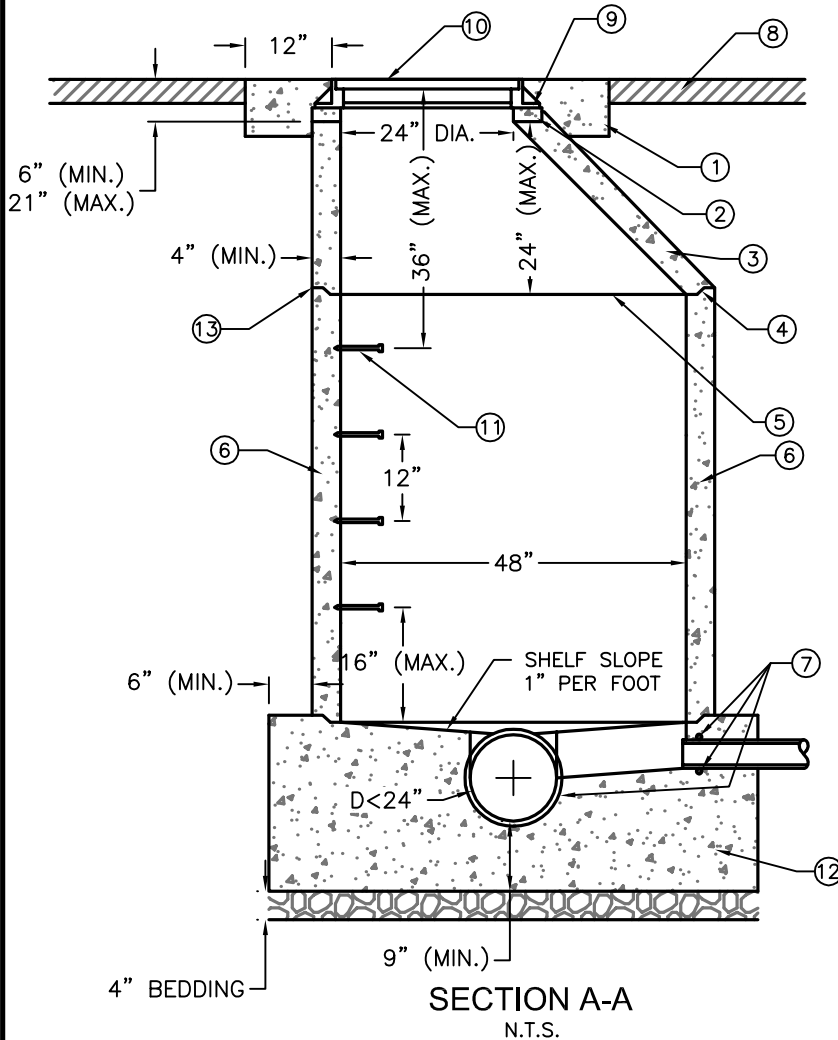

SECTION A-A
N.T.S.

NOTES:

- (A) PLACE VERTICAL WALL ON UPSTREAM SIDE OF MANHOLE, ROTATED 45 DEGREES.
- (B) MANHOLE FRAME AND COVER:
 - A. REQUIRED TO MEET ASTM A48
 - B. TRAFFIC RATED, H-20 WHEEL LOADING
 - C. MANHOLE FRAME AND COVER SHALL BE FLUSH WITH SLOPE OF PAVEMENT
- (C) WHERE PVC PIPE IS UTILIZED, INSTALL A RUBBER RING OR GASKET COLLAR WHERE THE PIPE IS IN CONTACT WITH MANHOLE BASE AND/OR MANHOLE CHANNEL, IN ORDER TO INSURE A WATERTIGHT SEAL.
- (D) PROVIDE MANHOLE CONCRETE REINFORCING TO ACCOMMODATE TRAFFIC LOADINGS.
- (E) BEDDING SHALL BE CLASS II AGGREGATE BASE CONFORMING TO THE STATE STANDARD SPECIFICATIONS.
- (F) PRECAST MANHOLE SECTIONS MUST MEET REQUIREMENTS OF ASTM C478

YOSE STANDARDS
FOR
SANITARY SEWER
CONSTRUCTION

STANDARD MANHOLE
YOSEMITE NATIONAL PARK
MAY 2012

STANDARD DRAWING
NO.

05-004

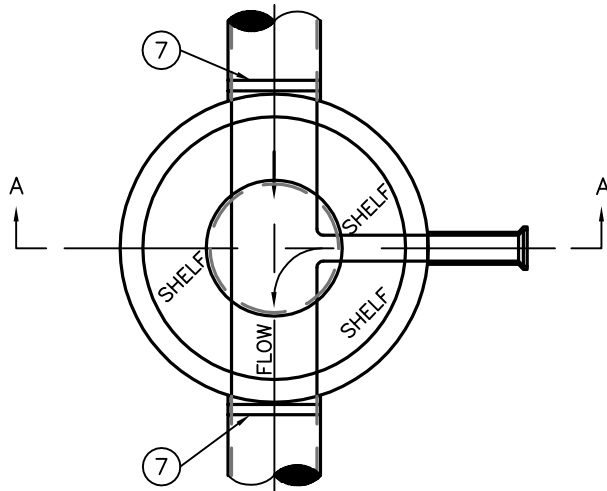

PLAN
N.T.S.

LEGEND:

- ① FRAME AND COVER.
- ② CONCRETE COLLAR IN PAVED SECTIONS PER SD-
- ③ FRAME TO BE GROUTED TO GRADE RINGS.
- ④ GRADE RINGS GROUTED IN PLACE.
- ⑤ CORE-DRILL THROUGH PRECAST SECTION.
- ⑥ CAST IN PLACE OR PRECAST CONCRETE BASE.
- ⑦ PRECAST GASKETED HUB RING OR RUBBER GASKETED COLLAR-FLEXIBLE AND WATER TIGHT.

NOTES:

- Ⓐ MANHOLE FRAME AND COVER:
A. REFER TO DRAWING NO. SD-507
B. FRAME AND COVER SHALL BE FLUSH WITH SLOPE OF PAVEMENT
- Ⓑ WHERE PVC PIPE IS UTILIZED, A RUBBER RING OR GASKET COLLAR IS TO BE INSTALLED WHERE THE PIPE IS IN CONTACT WITH MANHOLE BASE AND/OR MANHOLE CHANNEL, IN ORDER TO INSURE A WATERTIGHT SEAL.
- Ⓒ PROVIDE MANHOLE CONCRETE REINFORCING TO ACCOMMODATE TRAFFIC LOADING.
- Ⓓ BEDDING SHALL BE CLASS II AGGREGATE BASE CONFORMING TO THE STATE STANDARD SPECIFICATIONS.
- Ⓔ PRECAST MANHOLE SECTIONS MUST MEET REQUIREMENTS OF ASTM C478.

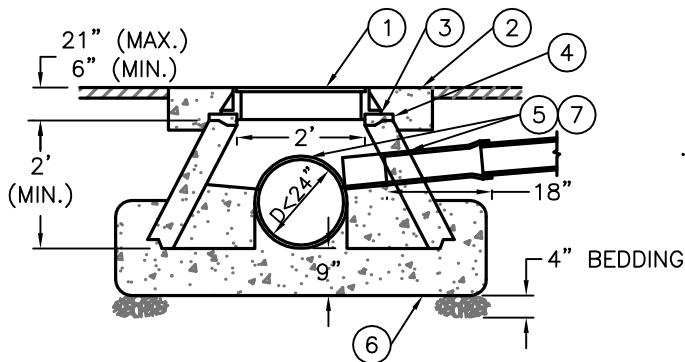

SECTION A-A
≥ 30" DEEP AND ≤ 48" DEEP
N.T.S.

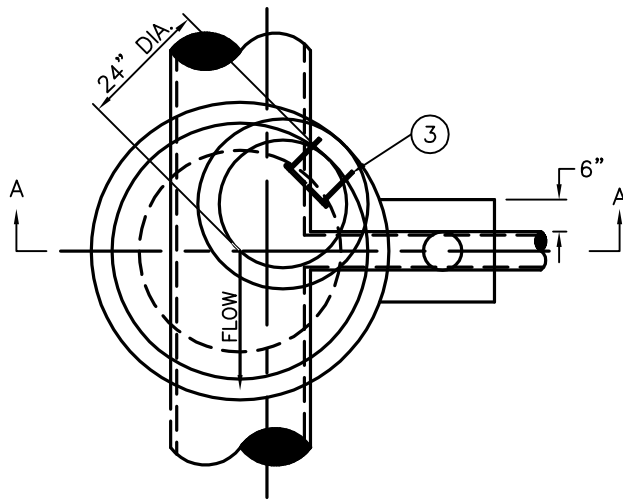

PLAN
N.T.S.

LEGEND:

- ① FRAME AND COVER.
- ② MANHOLE.
- ③ MANHOLE STEPS.
- ④ BEDDING MATERIAL.
- ⑤ CONCRETE BASE CAST IN PLACE.
- ⑥ EXTEND HALF PIPE DIAMETER INTO MANHOLE A MINIMUM OF 12".
- ⑦ FLEXIBLE JOINT.

NOTES:

- (A) PLACE VERTICAL WALL ON UPSTREAM SIDE OF MANHOLE.
- (B) MANHOLE FRAME AND COVER:
 - A. REQUIRED TO MEET ASTM A48
 - B. TRAFFIC RATED, H-20 WHEEL LOADING
 - C. MANHOLE FRAME AND COVER SHALL BE FLUSH WITH SLOPE OF PAVEMENT
- (C) WHERE PVC PIPE IS UTILIZED, A RUBBER RING OR GASKETED COLLAR IS TO BE INSTALLED WHERE THE PIPE IS IN CONTACT WITH MANHOLE BASE AND/OR MANHOLE CHANNEL, IN ORDER TO INSURE A WATERTIGHT SEAL.
- (D) IF THE DROP MANHOLE IS ON THE UPSTREAM SIDE, ROTATE MANHOLE 180 DEGREES SO THE VERTICAL WALL WILL BE DOWNSTREAM.
- (E) PROVIDE MANHOLE CONCRETE REINFORCING TO ACCOMMODATE TRAFFIC LOADING.
- (F) BEDDING SHALL BE CLASS II AGGREGATE BASE CONFORMING TO THE STATE STANDARD SPECIFICATIONS.
- (G) PRECAST MANHOLE SECTIONS MUST MEET REQUIREMENTS OF ASTM C478.

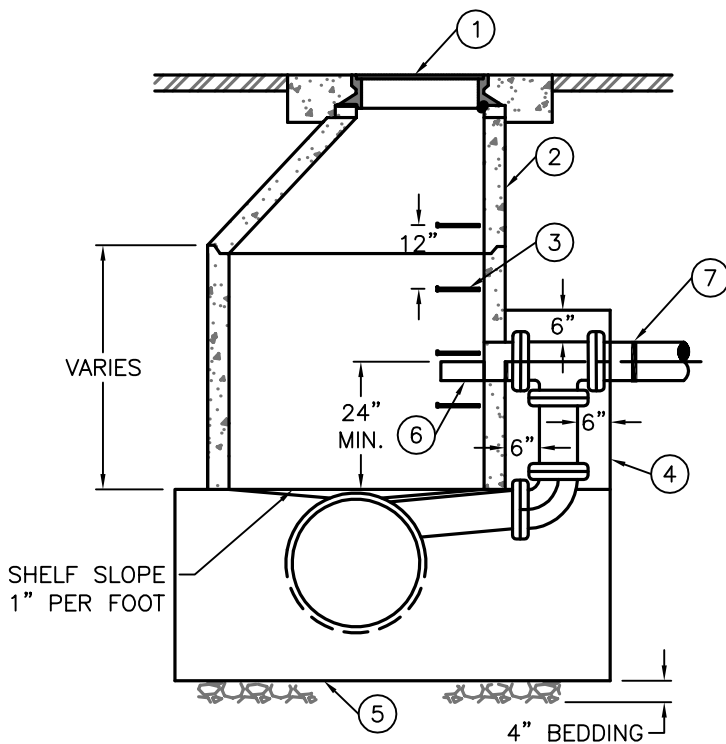

SECTION A-A
N.T.S.

YOSE STANDARDS
FOR
SANITARY SEWER
CONSTRUCTION

DROP MANHOLE
YOSEMITE NATIONAL PARK
MAY 2012

STANDARD DRAWING
NO.

05-006

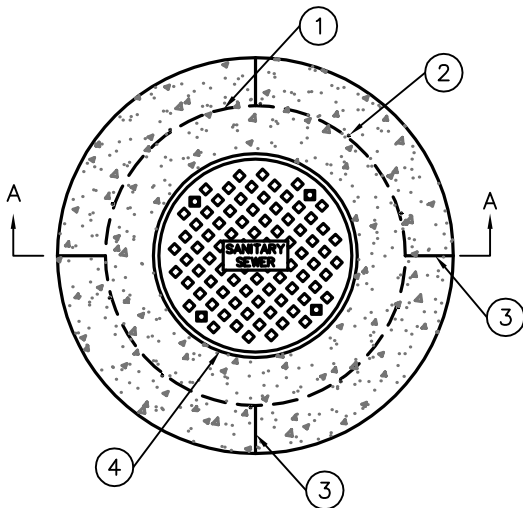

PLAN
N.T.S.

LEGEND:

- ① #4 REBAR HOOPS (2 EACH)
(SEE SECTION A-A).
- ② #4 REBAR AT 20" SPACING.
- ③ SCORES.
- ④ RIM.
- ⑤ FRAME AND COVER.
- ⑥ SEE "DETAIL A" FOR REBAR IN COLLAR.
- ⑦ FINISHED GRADE.
- ⑧ SEE OTHER STANDARD DRAWINGS OF
MANHOLES FOR MAXIMUM HEIGHT.
- ⑨ GROUT BETWEEN RING AND COVER AND
GRADE RINGS.
- ⑩ POLYPROPYLENE FIBER (ADDED PER
MANUFACTURER'S RECOMMENDATIONS)
MAY BE USED IN LIEU OF #4 REBAR IN
CONCRETE COLLARS.

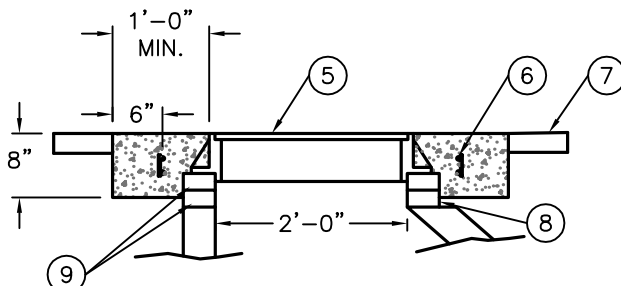

SECTION A-A
N.T.S.

NOTES:

- Ⓐ TOP OF COLLAR TO BE FLUSH WITH
MANHOLE COVER.

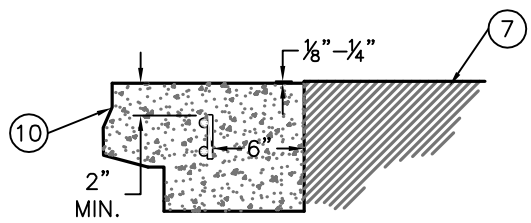

DETAIL A
N.T.S.

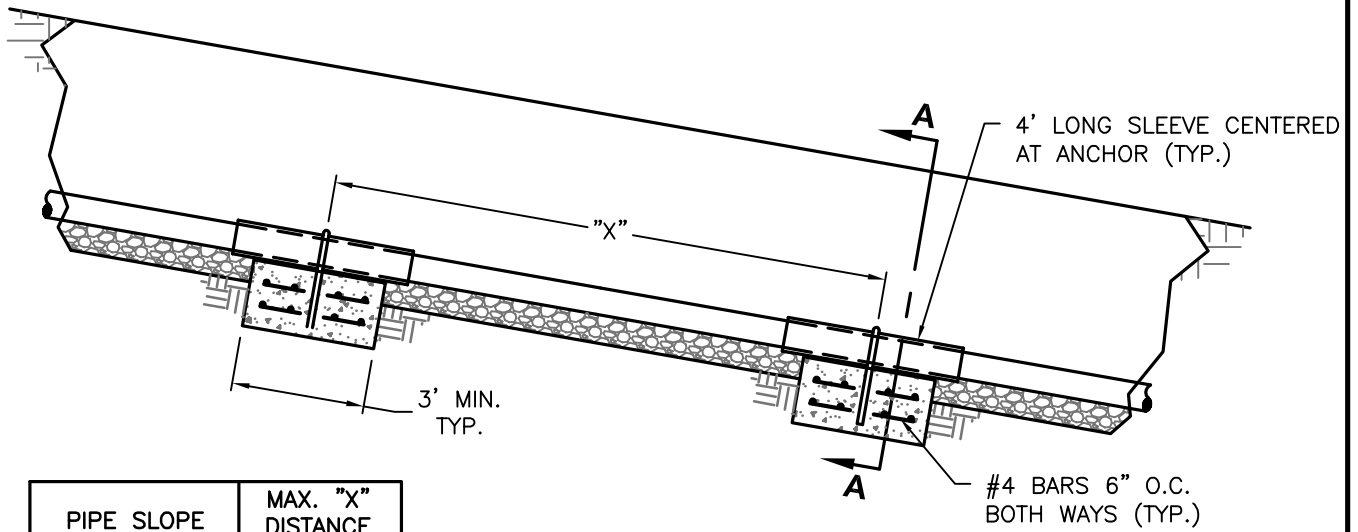

PIPE SLOPE	MAX. "X" DISTANCE
20% TO 35%	36'
35% TO 50%	24'
50% & OVER	16'

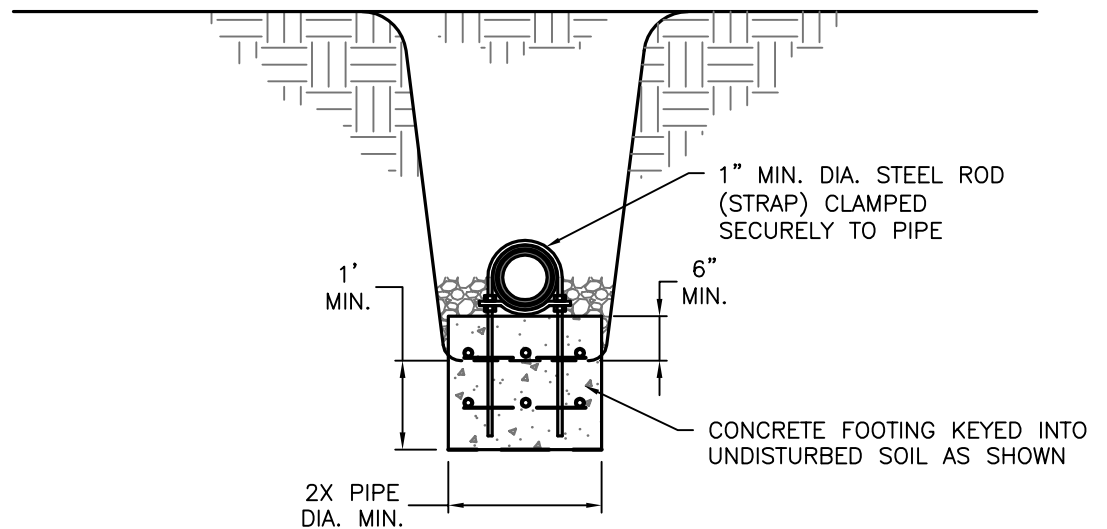

SECTION A-A

NOTES:

- A. 4' LONG SLEEVE MUST BE ONE PIPE SIZE DIAMETER LARGER THEN PIPE.
- B. PIPE ANCHORS REQUIRED ON SLOPES OF 20% OR GREATER.
- C. ALL REINFORCING STEEL TO BE #4 BARS.
- D. CONCRETE TO BE 5.5 SK/C.Y. 2500 PSI.
- E. POUR CONCRETE AGAINST UNDISTURBED EARTH.

YOSE STANDARDS
FOR
SANITARY SEWER
CONSTRUCTION

PIPE SLOPE ANCHOR
YOSEMITE NATIONAL PARK
MAY 2012

STANDARD DRAWING
NO.

05-008

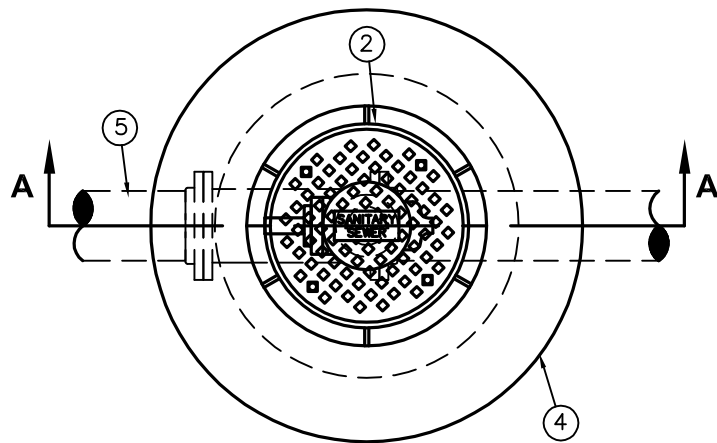

LEGEND:

- ① 24" DIAMETER RCP MANHOLE BARREL SECTION
- ② 24" MANHOLE FRAME AND COVER, SD-
- ③ LOCATING WIRE
- ④ CONCRETE COLLAR
- ⑤ PRESSURE SEWER PIPE
- ⑥ FLANGE ADAPTER
- ⑦ D.I. WYE (MJxMJxFL WYE) WITH JOINT RESTRAINTS
- ⑧ D.I. 45° ELBOW (FLxFL)
- ⑨ D.I. SPOOL (FLxPE); LENGTH VARIES PER LOCATION
- ⑩ ECCENTRIC PLUG VALVE (FLxFL)
- ⑪ (FL) ALUMINUM CAM LOCK WITH CAP
- ⑫ FLANGE ADAPTER

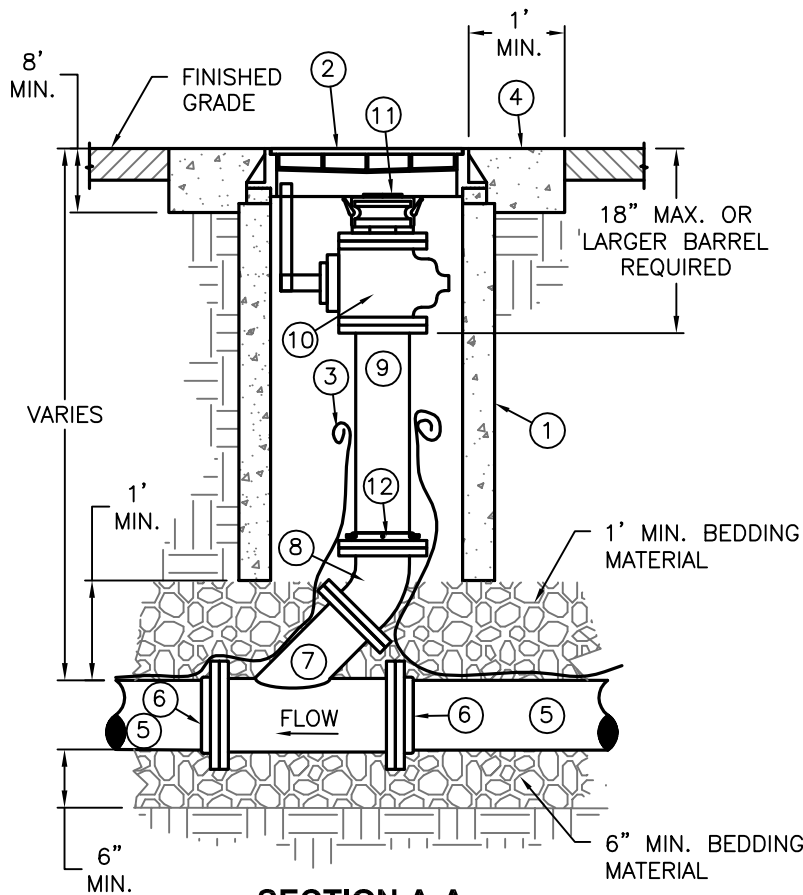

SECTION A-A

NOTES:

- (A) ALL PIPE AND FITTINGS TO BE DUCTILE IRON PIPE AND FITTINGS WITH THE FOLLOWING MODIFICATIONS:
 - A. EXTERNAL COATING: ASPHALTIC COATING, 0.025MM (1 MIL) THICK MINIMUM.
 - B. INTERNAL COATING: PROTECTO 401 CERAMIC EPOXY COATING, 1MM (40 MILS) THICK.
- (B) PLUG VALVE SHALL CONSIST OF MATERIAL THAT RESISTS CORROSION FROM CONTACT WITH A SANITARY SEWAGE ENVIRONMENT.
- (C) LOCATING WIRE MUST BE INSTALLED WITHIN THE CLEANOUT.
- (D) CLEANOUT ASSEMBLY SHALL BE PRESSURE RATED AND TESTED AS A PART OF FORCE MAIN.

YOSE STANDARDS
FOR
SANITARY SEWER
CONSTRUCTION

PRESSURE SEWER CLEAN-OUT
IN-LINE
YOSEMITE NATIONAL PARK
MAY 2012

STANDARD DRAWING
NO.

05-009

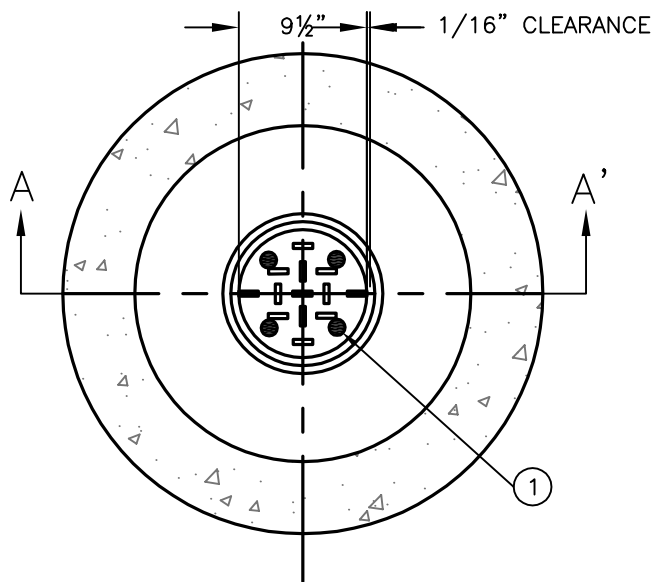

PLAN
N.T.S.

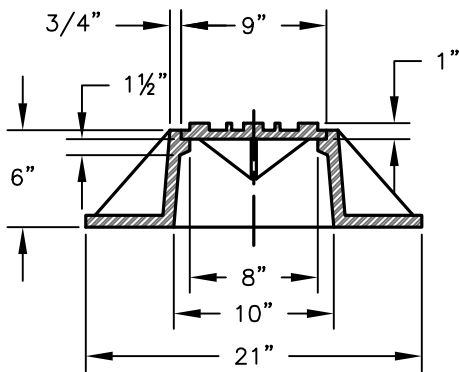

SECTION A-A
CAST IRON
RING AND COVER
N.T.S.

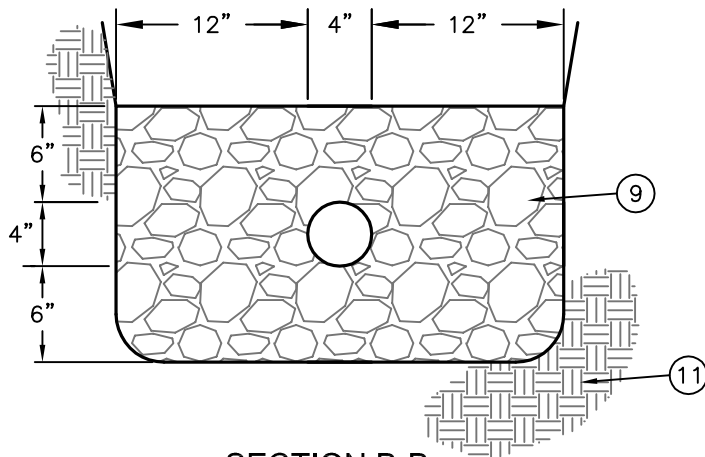

SECTION B-B
N.T.S.

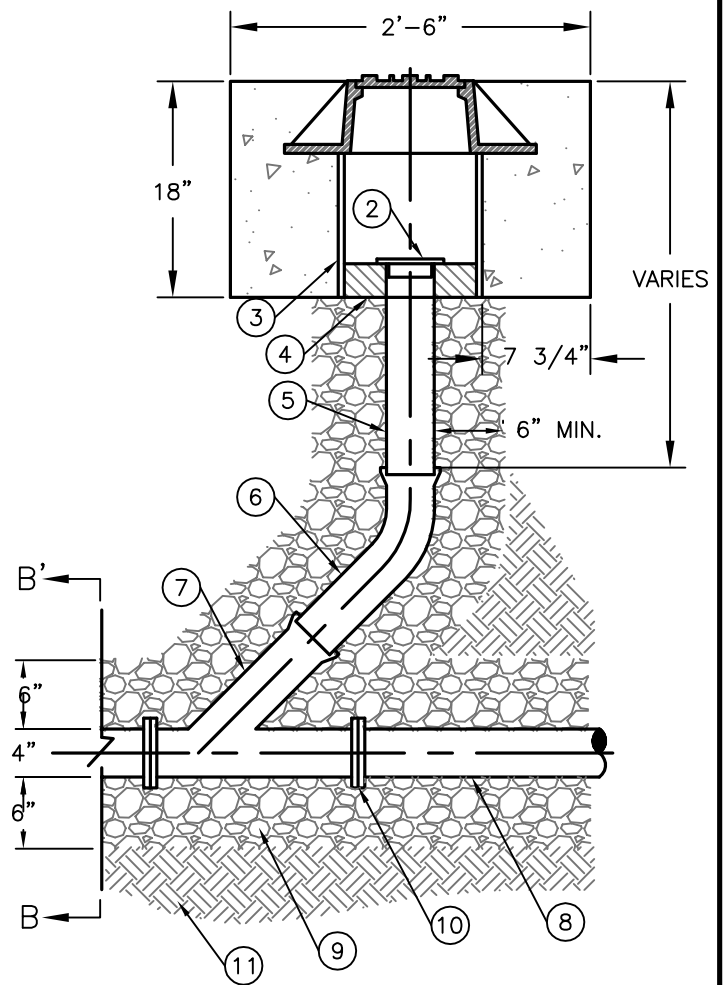

SIDE
N.T.S.

LEGEND:

- ① 4 - 1" DIA. HOLES ON 3 1/2" RADIUS.
- ② MECHANICAL PLUG.
- ③ 12" DIA. x 12" PVC, DIP OR CP.
- ④ FIBER JOINT MATERIAL.
- ⑤ PVC ASTM D 3034.
- ⑥ 45° BENDS.
- ⑦ "Y" FITTINGS.
- ⑧ EXISTING OR NEW PIPE.
- ⑨ BEDDING MATERIAL.
- ⑩ MISSION COUPLER OR APPROVED SUBSTITUTION.
- ⑪ UNDISTURBED MATERIAL.

YOSE STANDARDS
FOR
SANITARY SEWER
CONSTRUCTION

STANDARD 4" TRAFFIC
RATED CLEAN-OUT
YOSEMITE NATIONAL PARK
MAY 2012

STANDARD DRAWING
NO.

05-010

MATCH EXIST.
GROUND ELEV.

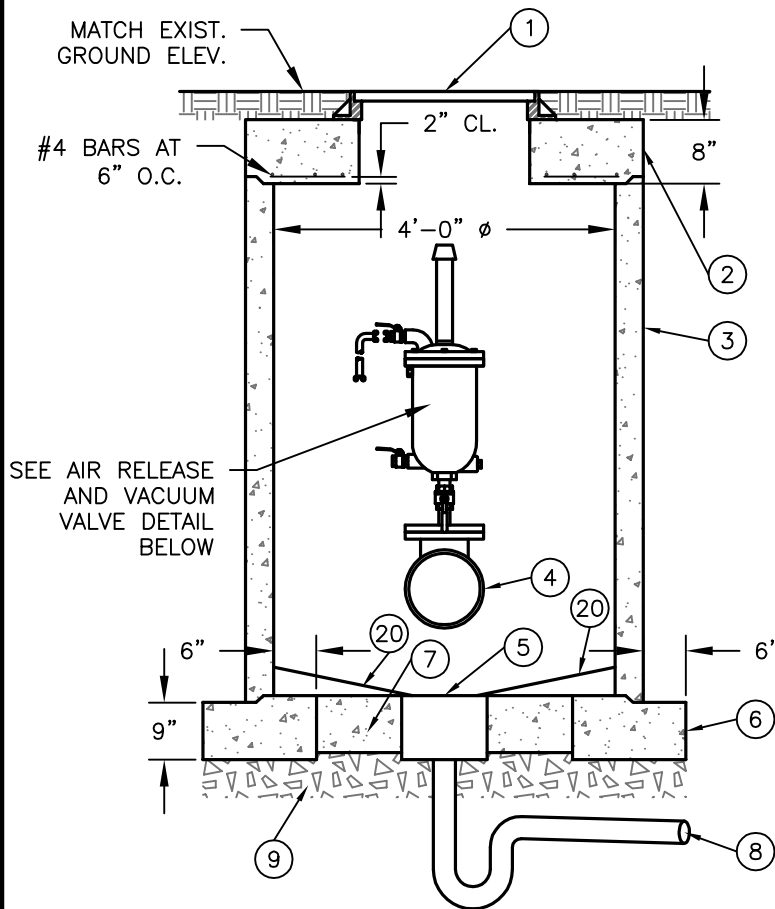

ELEVATION

N.T.S.

LEGEND:

- ① CAST IRON FRAME AND COVER MARKED "SANITARY"
- ② STANDARD MANHOLE SLAB. (8" THICK)
- ③ MANHOLE
- ④ PRESSURE SEWER
- ⑤ CAST IRON OR CONCRETE TRAP W/ GRATED LID
- ⑥ CONCRETE FOOTING
- ⑦ CONCRETE FLOOR
- ⑧ 4" DRAIN TO GRAVITY SEWER
- ⑨ 4" BEDDING MATERIAL
- ⑩ SHUT OFF VALVE (TYP)
- ⑪ QUICK DISCONNECT COUPLING
- ⑫ 1/2" FULL FLOW BALL VALVE WITH DISCONNECT COUPLING
- ⑬ OUTLET
- ⑭ 2" CLEAN-OUT
- ⑮ 2" THREADED CONNECTION
- ⑯ BLIND FLANGE TAPPED FOR 2" IPT NIPPLE
- ⑰ CAST IRON FLANGED X FLANGED TEE
- ⑱ BRONZE 1" FULL FLOW BALL VALVE
- ⑲ AIR/VACUUM VALVE SIZED FOR APPLICATION
- ⑳ GROUT AT 4:1 SLOPE
- ㉑ 1/2" RUBBER HOSE WITH QUICK DISCONNECT COUPLING ON EACH END
- ㉒ 1/2" N.P.T. PIPE PLUG

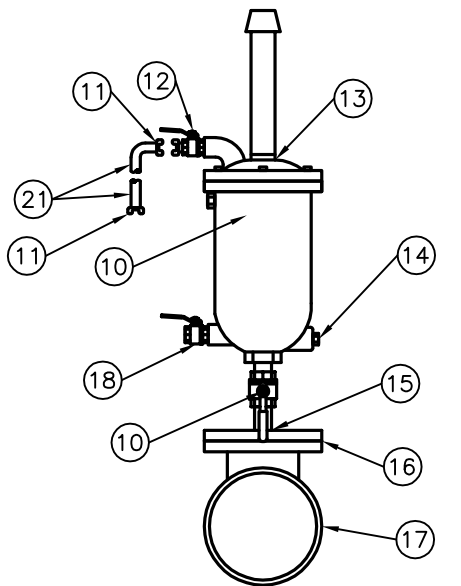

AIR RELEASE AND
VACUUM VALVE DETAIL

N.T.S.

NOTES:

- (A) PROVIDE MANHOLE CONCRETE REINFORCING TO ACCOMMODATE TRAFFIC LOADINGS.
- (B) PROVIDE PIPE SUPPORTS FOR DEEP INSTALLATIONS.

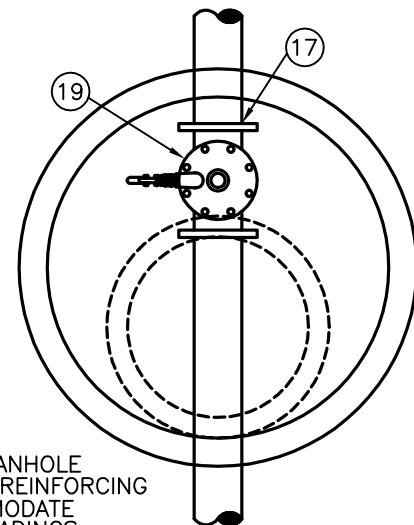

PLAN

N.T.S.

YOSE STANDARDS
FOR
SANITARY SEWER
CONSTRUCTION

COMBINATION AIR RELEASE/VACUUM VALVE
YOSEMITE NATIONAL PARK
MAY 2012

STANDARD DRAWING
NO.

05-011

LEGEND:

- ① GRAVITY SEWER INLET PIPE (LOCATION VARIES)
- ② BASE FOR DISCHARGE ELBOW, ANCHOR TO WET WELL
- ③ SUBMERSIBLE PUMP; ABS PHASE 3 OR APPROVED EQUAL PUMP ASSEMBLY INCLUDES MIXER ATTACHED TO PUMP PER MANUFACTURER'S REQUIREMENTS
- ④ DISCHARGE MATING FLANGE - PROVIDED BY MANUFACTURER
- ⑤ GUIDE RAIL: GUIDE RAIL AND SUPPORTS TO BE STAINLESS STEEL; DUAL RAIL FOR EACH PUMP
- ⑥ D.I. REDUCER FLxFL
- ⑦ SPOOL FLxPE
- ⑧ SPOOL SUPPORT - STAINLESS STEEL
- ⑨ 90° D.I. ELBOW FLxFL
- ⑩ SPOOL FLxPE
- ⑪ COUPLING "ROMAC" (STYLE 51) OR EQUAL, PROVIDE AXIAL RESTRAINT WITH FLANGE ADAPTERS, "DOG EARS" AND TIE RODS
- ⑫ CHECK VALVE FLxFL
- ⑬ PLUG VALVE
- ⑭ CROSS FL ADD SPOOLS BETWEEN CROSS AND ADJACENT FITTINGS FOR FIELD BOLT-UP AS NECESSARY, ADJUST DIMENSIONS OF VAULT AS REQUIRED
- ⑮ SPOOL PExPE
- ⑯ FLANGE ADAPTER, "EBBA IRON" (SERIES 1000) OR EQUAL
- ⑰ LIFTING CHAIN (STAINLESS STEEL), INCLUDE 4" STAINLESS STEEL "HOG RINGS" TO ATTACH CHAINS TO PUMPS
- ⑱ 2" - SCH. 80 PVC VAULT DRAIN WITH CHECK VALVE IN WET WELL
- ⑲ PLASTIC COATED MANHOLE STEPS, CONTRACTOR SHALL LOCATE STEPS TO BE ACCESSIBLE THROUGH HATCH LOCATION
- FJ FIELD JOINT. ALL JOINTS MUST BE 100% WATERTIGHT 12" EZ-WRAP.

LOCKABLE DOUBLE-DOOR ALUMINUM HATCH 48"x72" LOCATE TO ALLOW CLEAR VERTICAL ACCESS TO CAMLOCK AND VALVE OPERATORS

ELEVATION OF ALL VAULT LIDS, HATCHES AND MANHOLES TO BE SET AT 0.2 FEET ABOVE FINISHED GROUND

LOCKING FEMALE CAMLOCK FITTING W/ NIPPLE AND COMPANION FLANGE

LOCKABLE DOUBLE-DOOR ALUMINUM HATCH 48"x72" LOCATE TO ALLOW PUMP REMOVAL

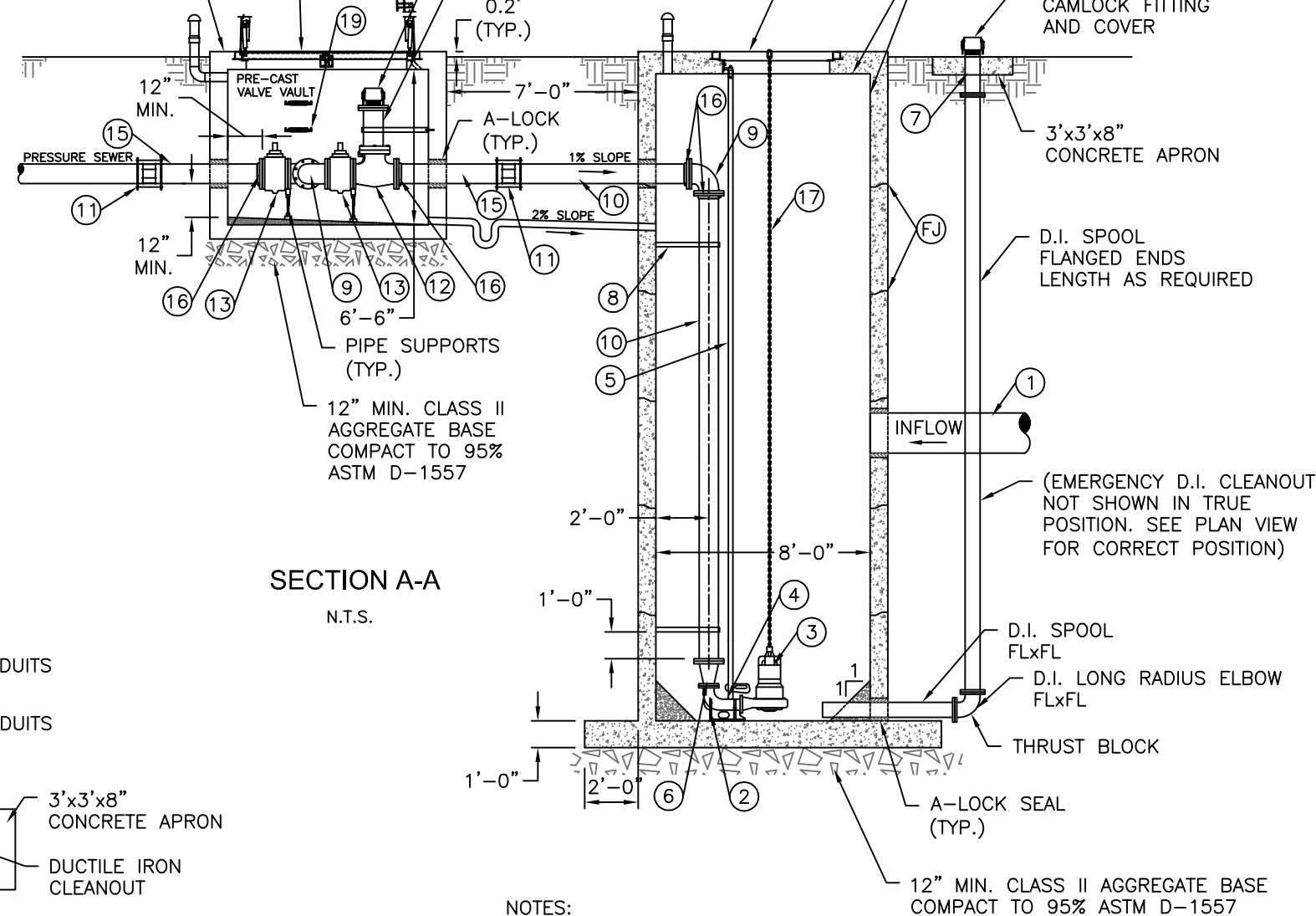

SECTION A-A
N.T.S.

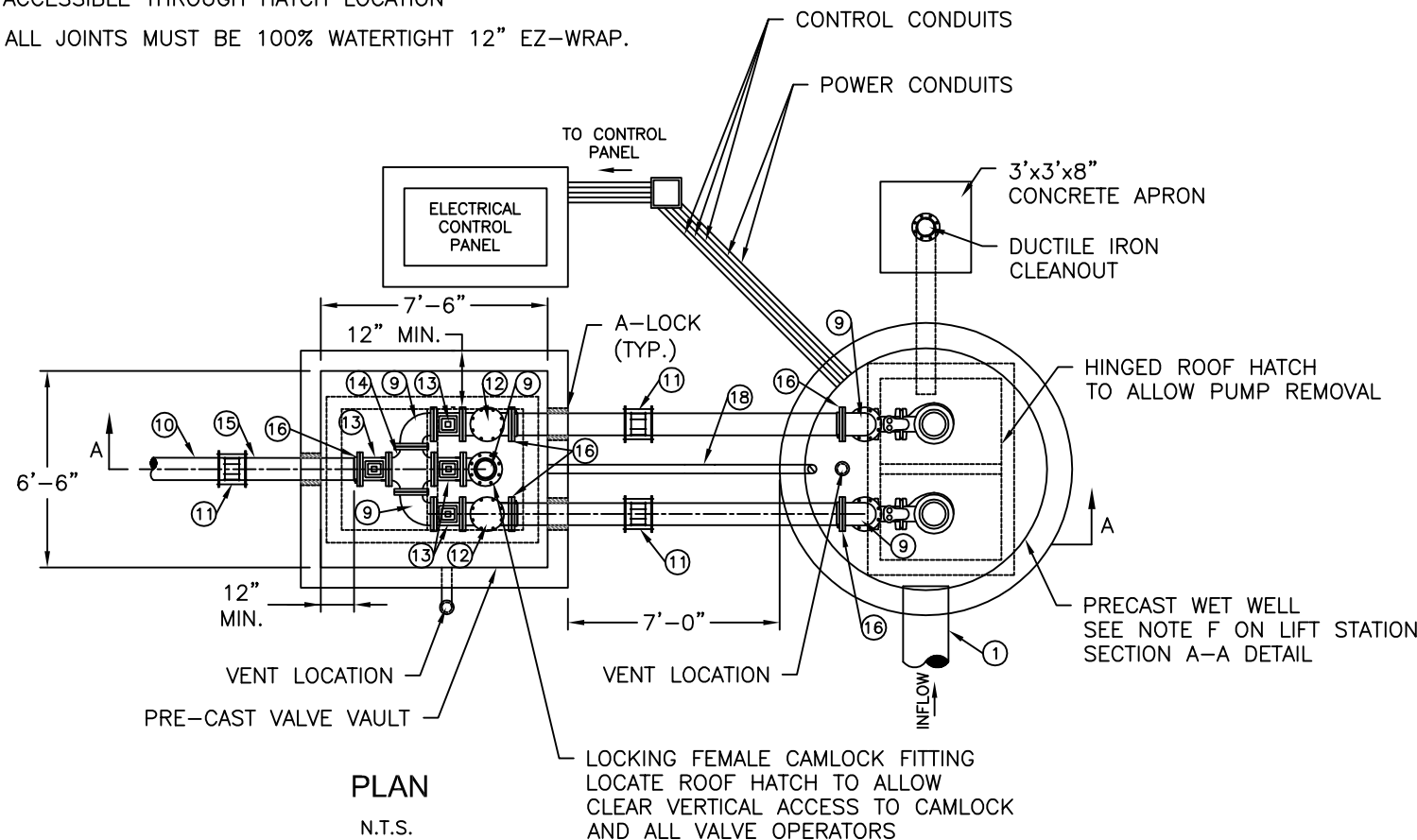

PLAN
N.T.S.

NOTES:

- (A) EXCEPT AS NOTED, ALL PIPE IS DUCTILE IRON CL-52 CONFORMING TO ALL RELEVANT AWWA STANDARDS. EXTERNAL COATING; ASPHALTIC COATING, 0.025 mm (1 MIL) THICK MINIMUM. INTERNAL COATING; PROTECTO 401 CERAMIC EPOXY COATING, 1mm (40 MILS) THICK.
- (B) ALL PIPE PENETRATIONS THROUGH MANHOLE WALL SHALL BE WITH "A-LOK" WATERTIGHT MANHOLE ADAPTERS.
- (C) CONNECT PIPE GUIDE RAIL(S) AND PUMP SUPPORTS TO MANHOLE IN ACCORDANCE WITH MANUFACTURER'S INSTALLATION INSTRUCTIONS.
- (D) ALL ANCHOR BOLTS & SHIMS SHALL BE STAINLESS STEEL.
- (E) ALL METAL IN WET WELL SHALL BE STAINLESS STEEL.
- (F) ALL VAULTS AND WET WELL SHALL BE WATERTIGHT HS-20 RATED.
- (G) FORCE MAIN SEPARATION DETERMINED BY VALVE ASSEMBLY. COORDINATE WITH PUMP RAIL MANUFACTURER ON SEPARATION OF PUMP AND GUIDE RAIL ASSEMBLY.
- (H) CONTRACTOR SHALL DETERMINE SIZE OF VAULTS REQUIRED TO ACHIEVE MINIMUM CLEARANCES SHOWN BASED ON SPECIFIC COMPONENTS FURNISHED AND INSTALLED.

EXHIBIT 5.2

CONSTRUCTION SPECIFICATIONS

SECTION 02 25 00

WASTEWATER COMBINATION AIR VALVE

PART 1 – GENERAL

1.1 SPECIFICATIONS

A. Scope

1. This specification is intended to cover the design, manufacture, and testing of Wastewater Combination Air Valves suitable for pressures up to one hundred-fifty (150) psig.
2. Wastewater Combination Air Valves shall be automatic float operated valves designed to exhaust air during filling of the piping system and close upon liquid entry. The valve shall open during draining or if a negative pressure occurs. The valve shall also release accumulated air from a piping system while the system is in operation and under pressure. The valve shall perform the functions of both Wastewater Air Release and Wastewater Air/Vacuum Valves.
3. Valve shall be a single body type, one (1) inch wastewater combination air valve, VM-801A as manufactured by Val-Matic Valve and Manufacturing Corporation, or equivalent.

B. Standards, Approvals and Verification

1. Valves shall be manufactured and tested in accordance with the American Water Works Association (AWWA) Standard C512.
2. Manufacturer shall have a quality management system that is certified to ISO 9001 by an accredited, certifying body.

C. Connections

1. Valves shall have full size NPT two (2) inch inlet and one (1) inch outlet. The body inlet connections shall be hexagonal for a wrench connection. The body shall have two (2) inch NPT cleanout and one (1) inch NPT drain connection on the side of the casing.
2. The valve shall have three (3) additional NPT connections for the addition of backwash accessories.

D. Design

1. Valves shall provide an extended body with a through flow area equal to the nominal size. Floats shall be unconditionally guaranteed against failure including pressure surges. The seat shall provide drop tight shut off to the full valve pressure rating.
2. Valves shall have a full port orifice, a double guided plug, and an adjustable threaded orifice button. The one (1) inch body shall be globe style to increase float clearance and reduce clogging. The plug shall be protected against direct water impact by an internal baffle and an extended float system. The plug shall have a precision orifice drilled through the center stem. The float shall include a sensitivity skirt to minimize spillage.

E. Materials

1. The valve body and cover shall be constructed of ASTM A126 Class B cast iron.
2. The float, plug, guide shafts, and bushings shall be constructed of Type 316 stainless steel. Non-metallic guides and bushings are not acceptable. Resilient seats shall be Buna-N.
3. The exterior of the valve shall be coated with a universal alkyd primer.

END OF SECTION

SECTION 02 32 00

UTILITY TRENCHING & BACKFILLING

PART 1 - GENERAL

1.1 DESCRIPTION:

- A. Trenching, backfilling and compacting for all underground utilities.

1.2 RELATED SECTIONS

- A. Section 02 32 10 – Utility Line Marking
- B. Section 02 51 00 – Pavement, Curbs, & Walks
- C. Section 15 06 00 – Pipe & Pipe Fittings: General Statement
- D. Section 15 06 50 – Pipe: Plastic PVC Sewer

1.3 REFERENCES

- A. American Society for Testing and Materials (ASTM)
 - 1. D1557, Test Methods for Moisture - Density Relations of Soils and Soil Aggregate Mixtures, Using ten (10) pound Hammer and eighteen (18) IN drop
 - 2. D4253, Test Methods for Maximum Index Density and Unit Weight of Soils Using a Vibratory Table
 - 3. D4254, Test Method for Minimum Index Density and Unit Weight of Soils and Calculation of Relative Density
- B. “Greenbook” Standard Specifications for Public Works Construction (latest edition)

1.4 SUBMITTALS

- A. Certifications and Testing consistent with Section _____. [*insert appropriate section reference*] and including:
 - 1. Furnish copy of certifications on granular materials for trench bedding and stabilization
 - 2. Furnish copy of density reports
 - 3. Certified weed and seed free

1.5 JOB CONDITIONS

- A. The Contractor shall contact Underground Service Alert (USA) (1-800-642-2444) seven (7) calendar days prior to start of each section and shall be responsible for maintaining a valid USA location tag through renewal during construction.
- B. The majority of the utilities within the Yosemite National Park (YNP) are owned by NPS. As such, very few utilities will actually be marked by the USA. It is the Contractor's responsibility to field locate and mark all utilities within the project work area. Field location and marking shall be performed a minimum of three (3) days prior to ground disturbance; notify Contracting Officer upon completion of field location and marking for Contracting Officer review and approval. No trenching shall be performed prior to Contracting Officer approval.
- C. For connections to existing piping, verify exact material, diameter, alignment, joint, etc. of existing piping.
- D. Take necessary precautions to protect existing utilities from damage due to any construction activity. Repair damages to utility items at no additional expense to Government.
- E. Avoid overloading or surcharge a sufficient distance back from edge of excavation to prevent slides or caving. Maintain and trim excavated materials in such manner to be as little inconvenience as possible to public and adjoining property owners.
- F. Provide full access to public and private premises, to fire hydrants, at street crossings, sidewalks or pathways and other points as designated by Contracting Officer to prevent serious interruption of travel.
- G. Protect and maintain benchmarks, monuments or other established points and reference points and, if disturbed or destroyed, replace items to full satisfaction of Contracting Officer.

PART 2 - PRODUCTS

2.1 MATERIALS

- A. Sub-grade Stabilization Material
 - 1. Clean gravel with reasonably uniform gradation from fine sand to maximum rock size of two and one half (2-1/2) inches at greatest dimension.
 - 2. Free of clay balls, organic matter, debris, and other deleterious matter.
 - 3. Gradation shall be such to fill all large voids with fines to prevent piping of native soil and prevent rapid and free movement of groundwater.
- B. Granular Bedding Material
 - 1. Bedding material shall be Class II Aggregate Base conforming to the State standards.

C. Backfill Material

1. Backfill material under paved areas, graveled roads, shoulders, parking lots, and driveways shall be Class II Aggregate Base conforming to the State standards. If concrete (slurry) backfill is indicated on the drawings, the mix shall comply with the following:
 - a. Concrete mix with each cubic yard containing one (1) sack of Portland Cement, twelve (12) gallons of water, eight-hundred (800) pounds of three-eighths (3/8) inch rock, and two thousand-six hundred (2600) pounds of sand.
2. Backfill for all other areas (Select Backfill) shall be Class II Aggregate Base conforming to the State standards. Suitable native or imported granular material may be used if allowed by the Park Contracting Officer.
 - a. Suitable Native Backfill
 - 1) Material excavated from the trench
 - 2) Free of rocks larger than three (3) inches at greatest dimension, roots, sod, organic matter, debris, frozen material, and other deleterious matter.

D. All imported materials shall be certified weed and seed free.

PART 3 - EXECUTION

3.1 EXCAVATION FOR APPURTENANCES

- A. Excavate for appurtenant piping structures to provide at least twelve (12) IN (minimum) clear distance between outer surface and embankment.

3.2 TRENCH EXCAVATION

- A. Excavate trenches by open cut method to depth necessary to accommodate work. Stockpile all soils for replacement and backfill.
- B. The Contractor will complete and clean up each phase of the work within a reasonable time from starting. No trench may be left open overnight. Trench plating capable of withstanding H-20 traffic loading may be used to cover trench.
- C. Observe following trenching criteria
 1. Trench size. Excavate only sufficient width to accommodate free working space. In no case shall trench width at top of pipe or conduit exceed the following dimensions

<u>Overall Diameter of Utility Service</u>	<u>Dimension</u>
--	------------------

8 inches and less	Max. 24-Inch +O.D.
-------------------	--------------------

2. Where soil conditions permit, cut trench walls vertically from bottom of trench to one (1) FT above top of pipe, conduit, or utility service.
3. Keep trenches free of water. Include cost of dewatering in original proposal.

4. Brace and sheet trenches as soil conditions dictate and in full compliance with OSHA requirements. Do not remove sheeting until backfilling has progressed to the stage that no damage to piping, utility service, or conduit will result due to removal.
5. Brace trenches running near walls or columns, to prevent any settlement or other disturbance of walls or columns.

3.3 PREPARATION OF FOUNDATION FOR PIPE LAYING

- A. If over-excavation occurs, backfill and compact to ninety (90) percent of maximum dry density per ASTM D1557 or backfill with granular bedding material.
- B. In case of rock excavation, carry excavation minimum of six (6) IN below established grade and backfill to grade with suitable earth or granular material. Form bell holes in trench such that only barrel of pipe is supported by bedding material.
- C. Sub-grade stabilization: Provide sub-grade stabilization when directed by the Contracting Officer in accordance with these specifications. Observe the following requirements when unstable trench bottom materials are encountered.
 1. Notify Contracting Officer when unstable materials are encountered and define by Drawing station locations and limits. Contracting Officer will evaluate the trench conditions and determine the quantity of stabilization and the amount of additional compensation.
 2. Remove unstable trench bottom caused by Contractor failure to dewater, rainfall, or Contractor operations. Replace with sub-grade stabilization with no additional compensation from the Government.

3.4 BACKFILLING

- A. Do not backfill until tests to be performed on system show system is in full compliance to specified requirements.
- B. Methods: Provide backfill and compaction methods of following types
 1. Granular Bedding (pipe zone) material. Furnish compacted bedding where indicated on the drawings or specified up to six (6) IN above top of pipe or conduit. Comply with the following:
 - a. Place backfill in lifts not exceeding eight (8) IN (loose thickness).
 - b. Hand place, shovel slice, and pneumatically tamp all bedding (pipe zone) material.
 - c. Observe specific pipe or conduit manufacturer's recommendations regarding methods of backfilling and compaction.
 - d. Ensure compaction of each lift to requirements stated in these specifications.
 2. Compacted backfill. Perform remaining backfill in accordance with the following:
 - a. Place backfill in lifts not exceeding eight (8) IN (loose thickness).
 - b. Observe specific pipe or conduit manufacturer's recommendations regarding methods of backfilling and compaction.

- c. Exercise extreme care in backfilling operations to avoid displacing joints and appurtenances or causing any horizontal or vertical misalignment, separation, or distortion. Repair damages, distortions or misalignments to full satisfaction of Contracting Officer.
 - 3. Place stored native topsoil as final backfill layer for unimproved areas outside paving.
- C. Water flushing for consolidation will not be permitted.

3.5 COMPACTION

- A. Compaction requirements: Place and ensure backfill and fill materials to achieve an equal or "higher" degree of compaction than undisturbed materials adjacent to the work; however, in no case shall degree of compaction be less than "Minimum Compaction" specified.
- B. Unless noted otherwise on drawings or specified by other sections of these specifications, comply with following trench compaction criteria.

LOCATION	SOIL TYPE	DENSITY
1. Bedding (pipe zone) materials - all areas	Cohesionless soils	Relative density of 70 percent by ASTM D4253 or D4254
	Cohesive soils	90 percent of maximum dry density by ASTM D1557
2. Compacted Backfill:		
A. Under pavements, roadways surfaces, within highway right-of-ways	Cohesionless soils	Relative density of 70 percent by ASTM D4253 or D4254
	Cohesive soils	95 percent of maximum dry density by ASTM D698
B. Under turfed, sodded, plant seeded, non-traffic areas.	Cohesionless soils	Relative density of 70 percent by ASTM D4253 or D4254
	Cohesive soils	90 percent of maximum dry density by ASTM D1557

- C. Moisture content at time of placement to be as follows:
- 1. Under roadway crossings or pavements, moisture content to be two (2) percent plus/minus of optimum moisture content, as specified in accordance with ASTM D698.
 - 2. In all other areas of trench construction, the moisture content will be adjusted by either the drying of the materials or wetting of the material to a percentage required to obtain the compaction as specified.

3.6 FIELD QUALITY CONTROL

A. Testing

1. Perform in-place moisture density tests as directed by the Contracting Officer to ensure trench backfill complies with specified requirements. Pay for all costs associated with compaction density tests. Where backfill compaction does not meet moisture density test requirements and after backfill has been removed as directed by Contracting Officer and situation corrected, perform additional tests as directed until compaction meets or exceeds requirements.
2. Moisture density tests are to be taken at a minimum of one (1) test per site or activity.

END OF SECTION

SECTION 02 32 10

UTILITY LINE MARKING

PART 1 - GENERAL

1.1 DESCRIPTION

- A. The work of this section consists of furnishing and installing locator tape in utility trench.

1.2 RELATED SECTIONS

- A. Section 02 32 00 – Utility Trenching & Backfilling

1.3 SUBMITTALS

- A. See Section _____. [*insert appropriate section reference*]
- B. Samples: one (1) foot length of locator tape.
- C. Certification that the materials used in the tape fabrication meet the requirements of this section.

PART 2 - PRODUCTS

2.1 METALLIC LOCATOR TAPE

- A. Solid aluminum foil, visible on unprinted side, encased in protective high visibility, inert polyethylene plastic jacket with solid aluminum film core.
- B. Foil Thickness: Minimum 5.5 mils.
- C. Width: four (4) inch minimum.
- D. Identifying Lettering: Minimum one (1) inch high, permanent black lettering imprinted continuously over entire length.
- E. Joining Clips: Tin or nickel-coated, furnished by tape manufacturer.
- F. Manufacturers and Products
 - 1. Reef Industries: Terra “D”.
 - 2. Allen; Detectatape.

2.2 LOCATOR WIRE

- A. Insulated, solid copper wire, ten (10) gauge, UF THWN or THHN.

PART 3 - EXECUTION

3.1 LOCATOR TAPE

- A. Install locator tape eight to ten (8" - 10") inches below the finished surface for sewer line installations. All buried sewer line trenches shall include locator tape. Locator tape shall indicate type of utility located below. Sanitary Sewer shall be identified by Green locator tape. Sample shall be submitted to Project Manager for approval prior to installation.

END OF SECTION

SECTION 02 40 10

SANITARY SEWER PIPE

PART 1 – GENERAL

1.1 DESCRIPTION

- A. The WORK under this Section includes providing all labor, materials, tools and equipment necessary for furnishing and installing sanitary sewer pipe, in accordance with these Specifications and in reasonably close conformity with the lines and grades shown on the Drawings or established by the CONTRACTING OFFICER.
- B. This WORK includes furnishings and installing connecting bands, branch connections, elbows or other fittings, and all appurtenances required to complete the sanitary sewer.

1.2 SUBMITTALS

- A. Sanitary Sewer Pipe: Material certifications stating conformance with the requirements of this Section.

PART 2 - PRODUCTS

2.1 DUCTILE IRON PIPE (GRAVITY AND PRESSURE SEWER)

- A. Ductile Iron Pipe shall conform to ANSI A21.51. Pipe and fittings shall be cement mortar lined in conformance with ANSI A21.4 and shall have an exterior bituminous coating conforming to the requirements of ANSI A21.10. Pipe joints shall conform to ANSI A2.11 and shall be push-on type as manufactured by United States Pipe and Foundry Company for Tyton pipe, or equal.
- B. Prior to the use of any pipe, the CONTRACTOR shall furnish a certification from the pipe manufacturer that all required tests have been made and that the pipe fully complies with the requirements of ANSI A21.51.
- C. Nominal pipe diameter is shown on the Drawings. No change in pipe diameter shall be made unless approved by the CONTRACTING OFFICER. The minimum pipe strength shall be thickness Class 52. The pipe size and thickness class shall be clearly marked on each pipe.
- D. Where special fittings are required, they shall be fabricated from steel pipe manufactured in accordance with AWWA Standard C200. The steel fitting shall be fabricated with spigot ends suitable for connection to the ductile iron pipe, with cast iron transition couplings as manufactured by Smith-Blair, Inc., or equal. Steel fittings shall be lined and coated with fusion epoxy system as supplied by Water Works Supply Company, Union City, California, or with hot applied coal tar in accordance with AWWA C203.

- E. Connections between ductile iron pipe and PVC pipe shall be made with "ROMAC" Stainless Steel Sleeve, or approved equal.

2.2 PVC SEWER PIPE

- A. PVC Sewer Pipe, four (4) inch through fifteen (15) inch in diameter, inclusive, shall have a standard dimension ratio (SDR) of 35, and conform to ASTM D 3034. Before any PVC pipe is used on this Project, the CONTRACTOR shall supply certifications, signed by an authorized agent of the seller or manufacturer, stating that the material has been sampled, tested, and inspected in accordance with ASTM D 3034.
- B. PVC Sewer Pipe greater than fifteen (15) inch in diameter shall conform to ASTM F 679. Before any PVC pipe is used, the CONTRACTOR shall supply certifications, signed by an authorized agent of the seller or manufacturer, stating that the material has been sampled, tested, and inspected in accordance with ASTM F 679.
- C. The pipe shall have integral wall bell and spigot joints conforming to ASTM D 3212. The bell shall consist of an integral wall section with a solid cross-section elastomeric ring, factory assembled, securely locked in place to prevent displacement.
- D. Flexible water-tight connections, approved by the CONTRACTING OFFICER, shall be used at PVC pipe connections to manholes and other rigid structures.

2.3 PVC PRESSURE PIPE

- A. PVC pressure pipe shall conform to the applicable requirements of ANSI/AWWA C900 and subject to additional requirements specified herein.
- B. The pipe shall be DR18, and shall be furnished complete with rubber gaskets.
- C. Fittings for PVC pressure pipe shall be cement mortar lined ductile iron in conformance with ANSI A21.4 and shall have an exterior bituminous coating conforming to the requirements of ANSI A21.10.
- D. All joints for the buried PVC pipe shall be either an integral bell manufactured on the pipe or a separate coupling both employing a rubber ring joint. The bell and coupling shall be the same thickness as of the pipe barrel, or greater thickness. The sealing ring groove in the coupling shall be of the same design as the groove in cast iron fittings and valves available from local water works supply distributors.
- E. Flexible water-tight connections, approved by the CONTRACTING OFFICER, shall be used at PVC connections to manholes and other rigid structures.
- F. Connections between PVC Sewer Pipe and PVC Pressure Pipe (PVC (HP)), shall be made with "ROMAC" Stainless Steel Sleeve, or approved equal.

2.4 HDPE PIPE

- A. High-Density Polyethylene (HDPE) pipe shall conform to ASTM D 3550 designation PE 3407 or PE 3408. Pipe for pressure sewer mains shall have a minimum pressure rating of one-hundred (100) psi and a Dimension Ratio (DR) of 17. Pipes for gravity sewer shall have a pressure rating of sixty-five (65) psi and a Dimension Ratio (DR) of 26. All HDPE shall have a standard iron pipe size (IPS) outside diameter.
- B. The pipe shall be homogeneous throughout and free of visible cracks, holes, foreign inclusions or other injurious defects. It shall be uniform in color, opacity, density, and other physical properties.
- C. The pipe shall be marked at five (5) foot intervals with a coded number which identifies the manufacturer, DR size, PPI rating, manufacturing standard reference and production code from which data and place of manufacturer can be determined.
- D. When HDPE pipe is connected to ductile iron pipe, a flange adapter shall be used. A flange-coupling adapter shall be used on the ductile iron pipe. HDPE flange adapters shall be manufactured by the same manufacturer as the pipe using the same resin as the pipe. Each flange adapter shall be furnished with a ductile iron convoluted back-up ring drilled to match the standard ANSI bolt pattern for the nominal diameter of pipe used.
- E. Connection of the pipe and fittings shall be performed by the thermal butt fusion system. HDPE pipe lengths, fittings, and flange adapter connections to be fused shall be of the same type, grade and class of polyethylene compound and supplied by the same raw material supplier.

2.5 PVC PRESSURE PIPE WITH RESTRAINED JOINTS

- A. Piping for PVC Pressure Pipe with Restrained Joints shall be PVC Pressure Pipe as specified above:
- B. Pipe joints shall be restrained using Uniflange Series 1350 joint restraints or approved equal.

PART 3 - EXECUTION

3.1 CONSTRUCTION

- A. Bedding and backfill shall conform to the requirements of Utility Trenching and Backfill.
- B. Sheeting and bracing required for trenches shall be removed to the elevation of the conduit, but no sheeting will be allowed to be pulled, removed, or disturbed below the conduit. Sheeting and bracing shall meet OSHA requirements.

- C. Before lowering into the trench; the pipe shall be inspected for defects. All cracked, chipped, or broken pipe shall be discarded. The ends and interior of the pipe shall be clean. Belled ends shall be laid upgrade. Handling of the pipe shall be accomplished in a manner that will not damage the pipe. The joint shall be made in the manner recommended by the manufacturer. Care shall be taken not to buckle or disturb previously laid pipe.
- D. Pipe shall be laid accurately to the staked line and grade. All service connections shall be installed as indicated on the Drawings. Where existing service sewers are to be connected, suitable fittings and adapters shall be provided by the CONTRACTOR.
- E. Pipe shall be cleaned of all foreign matter, and water shall be kept out of trenches until joints have been completed. When WORK is not in progress, open ends of pipe and fittings shall be securely closed to keep foreign matter and animals from entering.
- F. Each joint shall be inspected to ensure that it is properly made before backfilling is done. Care shall be taken to prevent any dirt or foreign matter from entering the open end of the pipe. Where it is necessary to cut pipe, such cuts shall be neatly made in an approved manner. The laid pipe shall be true to line and grade and, when completed, the sewer shall have a smooth and uniform invert. No section of gravity sewer, including service connections shall have an adverse grade which would pond water in the invert of the sewer.
- G. Connections to existing sewer mains, service connections, and manholes shall be made in such a manner so as to not damage the existing facility. Such connections shall be made so that no projections or rough surfaces occur within the pipe.
- H. Lateral connections to existing sewer mains shall not obstruct flow and shall be with a Romac CB saddle or equivalent. No "inserta tees" are allowed.
- I. Lateral connections to new sewer mains shall be made with a manufactured sanitary wye of the same material as the mainline pipe.
- J. Where gravity flow sanitary sewers cross above or less than eighteen (18) inches below waterlines, or approximately parallel water lines within ten (10) feet horizontally, the sewer pipe shall meet the requirements of ductile iron pipe or PVC pressure pipe, as described in Part 2 of this Section. All sewer mains shall be installed to the criteria for the separation of water mains and sanitary sewers set forth in the California Water Works Standards contained in the California Administrative Code. Any deviations from such requirements must be approved by the National Park Service.
- K. HDPE to HDPE connections shall be made by thermal butt fusion, in accordance with ASTM D2657. Fusion jointing shall utilize a pipe manufacturer approved fusion machine operated by experienced and qualified personnel. The CONTRACTOR shall provide three copies of a "Heat Fusion Qualification Guide," published by the HDPE manufacturer, that provides criteria for inspection of thermal fusion joints. The guide shall include criteria for operator training requirements and experience; visual inspection criteria (including photographs) for both intact thermal fusion joints and sample strips cut for thermal fusion joints. The thermal fusion machine operator shall perform a minimum of three test joints in the presence of the CONTRACTING OFFICER. The test joints will be examined from both exterior appearances and from appearance of the joint cross section once the samples have been cut into strips.

- L. Bolted HDPE to HDPE connections shall include a polyethylene flange adapter (stub end) butt fused to the pipe, a backup flange ring, bolts, nuts and a gasket. Flange rings shall be Standard Steel ring Flanges, Class D, in accordance with AWWA C207. High strength bolts, nuts, washers and gaskets shall be in conformance with AWWA C207, Appendix A. Flange rings, bolts, nuts and Washers shall be hot dip galvanized after fabrication per ASTM A153 and A386. Gasket dimensions and bolt lengths shall be per pipe manufacturer's recommendations.

END OF SECTION

SECTION 02 50 10

TESTING OF SEWER FORCE MAINS & APPERTENANCES

PART 1 - GENERAL

1.1 DESCRIPTION

- A. The work of this Section consists of low pressure air testing of wastewater force mains and appurtenances for the sole purpose of documenting deficiencies in the NPS Facility Management Software System database. It is not intended to be used as a test for new pipe installation acceptance.
- B. This procedure shall be used if the force main has not been or cannot be drained and/or access points are not available making a conventional internal camera inspection impossible. This guideline is to provide general procedures for testing of air release valves and low pressure air testing of wastewater force mains.
- C. If it is determined by the Contractor and NPS that the force main cannot be shut down for enough time to perform the low pressure air tests, the Contractor shall only perform the tests/checks on the air release valves and shall document any physical conditions present that may affect the performance of the force main system.
- D. The Contractor shall furnish all equipment and personnel for conducting the tests under the observation of the NPS Project Manager, Park POC and/or the Utility System Operator (herein referred to as NPS). The procedures and equipment shall be subject to the approval of the NPS.
- E. Testing Methods: Low pressure air testing and general observations. See Part 3.

1.2 QUALITY ASSURANCE

- A. This procedure shall be modified if any part of it presents a condition where a sewage spill could occur or damage to the lift station and/or force main could occur.
 - 1. Air test gauges shall have minimum divisions of 0.10 psi and have an accuracy of 0.0625 psi (one ounce per square inch). Gauges shall be ANSI B40.1-80, Grade 3A (plus or minus 0.25 percent of full scale accuracy), with a 15 psi dial range.
 - 2. All air used shall pass through a single control panel.

1.3 SUBMITTALS

- A. Before testing, provide the following information:
 - 1. Provide documentation of existing conditions. See Part 1.4C below.
 - 2. All Tests: Describe precautions that will be taken to protect system equipment that might be damaged under test pressures.

1.4 PROJECT CONDITIONS

- A. The Contractor and NPS Utility System Operator or other Park personnel in charge shall determine and agree that conditions are suitable for low pressure air testing prior to performing the test.
- B. Document all existing conditions prior to the start of the testing. Documentation shall include, but not be limited to, positions of valves (open/closed), utility vaults that show water infiltration, status of pump controls, etc. At the completion of the testing, all valves, equipment and controls are to be returned to their original position unless specifically directed not to by the NPS. Document any changes to the original settings when returning the system to normal operation after the testing.
- C. To accomplish any of the testing protocols, it must be possible for NPS to temporarily take the force main system out of service. The time required to complete the testing as outlined can not be determined prior to testing and will vary considerably from system to system. Perform tests at low use time in coordination with NPS. A temporary suspension of the testing may be required due to high volume of inflow. The contractor shall insure the capability to place the system back into normal operating mode if inflow is too great to keep the system out of service for the complete testing duration.
- D. At all steps of testing the NPS has the authority to approve or disapprove the exercising of a valve or other element on the system and the Contractor must explicitly receive the approval of the assigned on-site NPS contact before exercising any such elements. If disapproval of operating any of these elements precludes additional testing the contractor will cease testing operations and place the system back into service. Contractor shall document any decision to not move forward with the testing procedures.

1.5 SAFETY

- A. Pneumatic Plugs
 - 1. The pneumatic plugs must be firmly secured and care should be exercised in their removal. The total force on a twelve (12) inch plug at 4.0 psi is over four-hundred and fifty (450) pounds. Care must be exercised in not loading the sewer line with the full pressure of the compressor.
- B. Confined Space:
 - 1. Only trained and certified personnel shall be allowed to enter confined space locations. All confined space requirements are to be observed
- C. Traffic Control:
 - 1. Personnel on-site shall have adequate traffic control measures in place. Hard hats and safety vests are required to be worn by all personnel in attendance

PART 2 - PRODUCTS - NOT USED

PART 3 - EXECUTION

3.1 GENERAL

- A. Perform testing in the presence of the NPS. Notify the NPS Point of Contact at least forty-eight (48) hours prior to testing.
- B. Protect system equipment susceptible to damage by test pressures. Return services to full operation when required.

3.2 AIR RELEASE VALVES (ARV)

- A. Test air release valves first. Air release valves are typically located a long distance from the lift station pumps and/or discharge outlet of the force main. It is not possible to test their performance by pressurizing the pipeline from the discharge end as the air must travel to the high point to be vented by the ARV. Two (2) tests can be performed to determine functionality of the valves.
- B. All water and/or debris that have accumulated in ARV utility vaults shall be removed prior to the start of the testing.
- C. Perform tests in coordination with the lift station wet well pump down process for the force main low pressure air test.
 - 1. ARV Test 1: Verify the inlet valve between the force main and the ARV is open. Observe the ARV when the force main is pressurized under normal operating conditions. Perform this test in conjunction with pumping down the lift station wet well for the low pressure air test if possible. If liquids are forced out of the ARV, it is assumed to be plugged and will require maintenance.
 - 2. ARV Test 2: Perform this test when the force main is in a static condition. Close the inlet valve between the force main and the ARV. Open the blow-off valve (near bottom of ARV) and observe if fluid drains out the valve body rapidly, flushing is not required and the valve is assumed to be operating properly. Should fluids not drain rapidly or at all, the valve must be flushed in accordance with the manufacturer's recommendations. The contractor is document the need for the maintenance and is not to perform the task.

3.3 LOW PRESSURE AIR TEST

- A. Test force main with low pressure air. Safety requires a regulator or relief valve on pressurizing equipment, set at eight (8) psig. No one will be allowed in manholes while there is air pressure against test plugs.

1. In coordination with the NPS, pump down the lift station wet well to the lowest level possible. Plug all inflow lines to maintain a constant level in the wet well while the system is shut down. Measure the depth from point on rim to fluid level accurately.
 - a. If the lift station and force main have been out of service for an extended period of time, water shall be introduced to completely fill the line prior to the air test.
 - b. All air/vacuum relief valves shall be closed prior to the start of the test.
2. Simultaneously, plug discharge end of force main pipe with a pneumatic plug equipped with a flow through air fitting capable of pressurizing the sewer line. The plug shall have remote air hose/gauge/rope combinations suitable for the testing purposes described herein. Make every effort to avoid entering the manhole to install the plug.
3. The pipe shall be tested with low pressure air. Air shall be slowly supplied to the plugged pipe installation until the internal air pressure reaches four (4.0) pounds per square inch. DO NOT EXCEED NINE (9) PSI.
4. At least five (5) minutes shall be allowed for temperature stabilization before proceeding further. After the five (5) minute temperature stabilization period, re-pressurize to the (four) 4.0 pounds per square inch. Disconnect the air supply.
5. The line being tested shall be termed "Acceptable" if the time required in minutes for the pressure to decrease one (1) psig is not less than the time shown for the given diameters in the following table:

PIPE DIAMETER	MINUTES
4"	2.0
6"	3.0
8"	4.0
10"	5.0
12"	5.5
15"	7.5
18"	8.5
21"	10.0
24"	11.5
*Time in Minutes = 0.472 D D = Diameter of pipe in inches	

When a combination of more than one pipe size is under test, the calculated time for the larger pipe shall apply.

6. If the pipe fails to meet these requirements, the first location to investigate is the performance of the check valves. If bubbles are observed in the wet well and they originate below the pump(s) or the wet well level rises, the assumption is the check valves are leaking or the internal pipe is deteriorated. At this point the Contractor shall close the gate valve(s) immediately downstream of the check valves. Repeat the test. If the pipe meets acceptability requirements, the assumption is the check valves are leaking.

7. If the pipe continues to fail to meet the acceptable requirements, the Contractor shall begin to isolate the different sections of the pipe. Working from the lift station towards the force main discharge end, close the first isolation valve downstream of the gate valves at the lift station and repeat the test. If the test is acceptable, the leak is assumed to be between the lift station gate valves and the first downstream isolation gate valve. If the test is unacceptable, open the first isolation valve and close the second isolation valve downstream of the lift station. Repeat the test. Continue this procedure until the leak location is determined
8. Document each step in detail as progress is made towards a complete test.
9. Return the system to normal operating conditions at the completion of testing.

END OF SECTION

SECTION 02 51 50

MANHOLE STRUCTURES

PART 1 - GENERAL

1.1 SECTION INCLUDES

- A. Manholes and appurtenances.

1.2 REFERENCES

- A. American Society for Testing and Materials (ASTM):
 1. ASTM A48, Gray Iron Castings (Class 35 Minimum)
 2. ASTM C150, Portland Cement
 3. ASTM C478, Pre-cast Reinforced Concrete Manhole Sections
 4. ASTM C1244, Concrete Sewer Manhole Negative Air Pressures (Vacuum) Test

1.3 SUBMITTALS

- A. See Section _____. [*insert appropriate section reference*]
- B. Include detailed diagrams of manholes showing typical components and dimensions.
- C. Itemize, on separate schedule, sectional breakdown of each manhole structure with all components and refer to drawing identification number or notation.
- D. Indicate knockout elevations for all piping entering each manhole.

PART 2 - PRODUCTS

2.1 ACCEPTABLE MANUFACTURERS

- A. Subject to compliance with the Contract Documents, the following manufacturers are acceptable:
 1. Manhole steps, rings, covers and frames:
 - a. Neenah Foundry
 - b. Deeter Foundry
 - c. J Mark Corporation
 - d. Municipal Castings
 - e. Castings, Inc.

2. Pre-molded Joint Compound
 - a. Ram Nec
 - b. Kent Seal

2.2 SANITARY SEWER MANHOLE STRUCTURE COMPONENTS

- A. Manhole sections. Provide manhole sections reinforced in compliance to ASTM C478. Provide a minimum section wall thickness of five (5) inches. Adjust final minimum six (6) inches to maximum eighteen (18) inches distance to grade by using pre-cast adjuster rings. Provide the following components for the manhole structures to be replaced:
 1. Pre-cast manhole bases or cast-in-place manhole bases.
 2. Pre-cast Bottom Section
 3. Pre-cast Barrel Section(s)
 4. Pre-cast Transition Section (Concentric or Eccentric)
 5. Pre-cast Adjuster Ring(s)
- B. Cast-In-Place Manhole Bases
 1. Twenty-eight (28) day Compressive Strength: three-thousand (3000) psi
 2. Type II, per ASTM C150, Modified Sulfate Resistant Concrete, tricalcium aluminate content limited to four (4) percent or less.
- C. Frames and Cover
 1. Provide cast or ductile iron frame and covers made of material meeting ASTM A48, Class 35 (minimum).
 2. Use only cast or ductile iron of best quality, free from imperfections and blow holes.
 3. Furnish frame and cover of heavy-duty construction, a minimum total weight of four-hundred (400) pounds.
 4. Machine all horizontal surfaces.
 5. Furnish lid with four one (1) inch pick holes. Letter covers "SANITARY SEWER" for all collection system manholes.
 6. Ensure minimum clear opening as shown on the Drawings.
- D. Manhole Steps
 1. Provide each manhole with extruded aluminum manhole steps with a safety tread. Furnish spacing and dimensions of steps complying with OSHA requirements for fixed ladders. Copolymer polypropylene coated steel steps (MA Industries Model PS-2-PF) are also acceptable.
 2. Ensure maximum distance from surface to first rung is not greater than sixteen (16) inches and that maximum spacing on remaining steps is twelve (12) inches on center. Locate step such that center of rung is nominal six (6) inches clear of wall.
 3. Minimum step width of fourteen (14) inches and minimum cross section of 0.875 inch of solid material.
 4. Embed a minimum of three (3) inches and anchor integrally into manhole or structure walls.

E. Flexible Pipe-to-Manhole Connector

1. A flexible pipe-to-manhole connector shall be used in the connection of the sewer pipe to pre-cast manholes.
2. The connector shall be Kor-N-Seal as manufactured by NPC Inc., or equal.
3. Internal expander assembly and external pipe clamp shall be Type 316 stainless steel.

F. Coating

1. Coat the exterior of all manholes with a Conceal 55 coating or approved equal.

PART 3 - EXECUTION

3.1 MANHOLE CONSTRUCTION

A. General

1. Make inverts with a semicircular bottom conforming to the inside contour of the adjacent sewer sections.
 2. Shape inverts accurately and give them a steel trowel finish. For changes in direction of the sewer and entering branches into the manhole, make a circular curve in the manhole invert.
 3. Provide a minimum of 0.2-foot fall across all manholes.
- B. Build at such elevation that pipe sections built into wall of manhole will be true extensions of line of pipe.
- C. Set and adjust frame, and cover to match finished pavement grade elevation. In unimproved areas, the top of the frame shall be elevated 6-inches above finished grade.
- D. Manhole sections shall be set with pre-molded joint compound.
- E. Seal all external joints with twelve (12) inch EZ-Wrap or equivalent per manufacturer's requirements.

3.2 MANHOLE TESTING

- A. Manholes shall be tested for leakage separately from the pipe. The sewer pipe in the manhole shall be plugged. All manholes shall be vacuum tested. The test shall be in compliance with ASTM C1244-93 "Standard Test Method for Concrete Sewer Manholes by the Negative Air Pressure Test".
- B. No manhole will be accepted that has any visible infiltration when empty.
- C. Any manhole whose test is unsatisfactory shall be repaired and retested until satisfactory results are obtained.

END OF SECTION

SECTION 02 53 10

SEWER LINE CLEANING

PART 1 – GENERAL

1.1 PROJECT SUMMARY

- A. Contractor shall perform a complete closed circuit television (CCTV) inspection of all sewer lines four (4) inches and larger. The work includes a pre-cleaning CCTV inspection to document conditions that could be removed during cleaning; hydro-cleaning of the lines when necessary and follow up with a post-cleaning CCTV inspection. The CCTV documentation will be completed in accordance with the National Association of Sewer Service Companies (NASSCO) standards for pipeline and manhole condition assessments (PACP® and MACP®). Manholes will be inspected and their condition documented through completion of the database entries and still photos. Work also includes testing of force mains and appurtenances. Final documentation will include submittal of multiple copies of printed pipe segment inspection reports, the electronic database, written reports of force main test results and the digital video inspections.

- B. Pre-cleaning CCTV
 - 1. The pre-cleaning CCTV video inspection of all sewer lines four (4) inches and larger includes all main lines, branch lines and laterals. The pre-cleaning video will document all defects that could be easily removed by high pressure hydro cleaning methods. If determined the line does not need cleaning, only one video will be performed that will document all defects, conditions and changes in materials. The pre-cleaning video will become part of the permanent record and defects found during that inspection will be included in the electronic database. The pre-cleaning CCTV digital files will be submitted to the NPS as part of the final deliverables.

- D. Cleaning
 - 1. If the sewer line requires cleaning, the line shall be cleaned by high pressure hydro-flushing and/or hydro-vacuuming following the pre-cleaning CCTV documentation. All debris shall be caught and removed from each downstream manhole and shall not be transported from manhole to manhole by the hydro-flushing method. Numerous passes with the cleaning equipment may be required to get an accurate view of the pipeline condition.

- E. Post-cleaning CCTV
 - 1. Following cleaning, the line shall be video taped again to document all defects relating to the structure and condition of the line and changes in materials. Documentation shall include digital video with verbal descriptions of each defect or changes in conditions and/or materials on the video, still photos of defects, printed copy of the reports of all segments inspected and electronic data files.

F. Manhole Inspections

1. Manholes will be visually inspected and their construction specifications documented as per the MACP® standards. The manhole conditions will be documented in the electronic database. Digital still photos will be taken, added to the database and included with the final deliverables. Include a drawn graphic of the manhole invert showing all the influent and effluent lines. Graphic shall be in the same orientation as the photo of the invert.

G. Force main testing / inspection

1. Force mains will be pressure tested using low pressure testing methods. Testing may involve multiple efforts to determine locations of defects. Results will be documented and included with final deliverables. See Section 02 50 10 – Testing of Sewer Force Mains & Appurtenances.

1.2 SUBMITTALS

A. Submit the following prior to the start of the work:

1. Written procedure for cleaning and debris removal: Include descriptions of equipment to be used including types of heads, pressure ratings, flow volumes, and condition (new, slightly used, used). Describe vacuum/jetting equipment specifications.
2. Record Drawings: Contractor shall provide contract maps marked up according to conditions found during cleaning operations at the completion of the work. Record Drawings shall have critical observations clearly marked by hand in RED INK. See paragraph 1.14.C below.

1.3 CLOSED CIRCUIT TELEVISION (CCTV) INSPECTION SCHEDULE

- A. The Contractor shall complete CCTV inspection per Section 02 53 40 immediately following cleaning to allow clear viewing of the sewer pipeline condition by the camera. A cleaned pipe reach shall be CCTV inspected within twenty-four (24) hours elapsed time of being cleaned. The pipeline reach shall be re-cleaned if solids obstruct the camera view and re-cleaning shall be at no additional cost to the Government.

1.4 MANHOLE CLOSURE

- A. All existing manholes should be equipped with a solid well fitting cast iron cover with no drain or through-pick holes and may include a PVC infiltration lid beneath the cast iron cover. The Contractor shall reinstall any infiltration lids and cover following cleaning.

1.5 BYPASS CONDITIONS ASSESSMENT

- A. Contractor shall assess each pipeline segment for bypass pumping needs. The assessment shall include: Identification of possible spill flow paths to a water course such as streams or rivers, developing a site specific Spill Prevention and Response Plan, and providing bypass equipment if needed, sand bags and other spill prevention and response equipment

and materials prior to proceeding with the work. The site specific Spill Prevention and Response Plan shall be approved by the Park Point of Contact (POC) and NPS Project Manager prior to proceeding with the work. Reference Section 01 35 50 for SPRP requirements

- B. Equipment and materials shall be available as identified in the site specific Spill Prevention and Response Plan. In addition, equipment and material shall be standing by and ready within thirty (30) minutes in the event of a spill.

1.6 PRESSURIZED GRAVITY LINE CLEANING

- A. Contractor shall inspect all pressure cleanout locations and air release valves and develop a site specific spill prevention plan associated with opening the cleanout for cleaning. These cleanouts are generally on steep pipelines and are subject to pressures during blockages or surcharge conditions. Any compromised, damaged or unsound cleanout, cleanout pipe, cleanout lid and cover shall be reported immediately to the Government with a recommendation for repair.
- B. Contractor shall coordinate the cleaning schedule of these pipelines and the work may involve working either prior to or after the peak visitation hours or possibly peak visitation seasons to reduce flows in the pipeline.
- C. Situations may exist where it is neither safe, nor feasible to inspect a line. The contractor shall document the situation and proceed to the next area.

1.7 PRESSURIZED FORCE MAIN CLEANING

- A. See Specification Section 02 50 10 – Testing of Sewer Force Mains & Appurtenances.
- B. Not all force mains are suitable for cleaning. Many force mains only have access points at either end. Access points along the length of the force main may not exist. Coordination with the Park POC and utility system operators is required prior to any operation that involves force mains.
- C. Contractor shall inspect all pressure cleanout locations and air release valves and develop site specific spill prevention plans associated with opening the cleanout for cleaning. These cleanouts are subject to pressures during routine operations as well as static conditions. Any compromised, damaged or unsound cleanout, cleanout lid and cover shall be reported immediately to the Park POC with a recommendation for repair.
- D. Contractor shall coordinate the cleaning schedule of these pipelines and the work may involve working either prior to or after the peak visitation hours or possibly peak visitation seasons to reduce flows in the pipeline.

1.8 MINIMUM EQUIPMENT ONSITE

- A. Contractor shall maintain an adequate supply of backup equipment and parts at all times. Work locations are such that ready access to repair parts is very limited and may require several hours of travel time. Time lost due to equipment breakdown and/or lack of repair parts will not be chargeable to the Government.

1.9 FLOW CONTROL WITHOUT BYPASS PUMPING

- A. Divert sewage flows and storm water around all sewer cleaning areas as needed. Depth of flow shall be limited to less than one-third (1/3) of the diameter of the pipe. If flow is greater than one-third (1/3) the diameter of the pipe, the video work shall be postponed for more favorable conditions or non-pumping flow control methods may be employed. Furnish, install, and manage plugs, conduits, and other equipment to lessen or divert the flow of sewage through or around the pipeline reach in which work is to be performed. Pneumatic plugs shall be designed so that all or any portion of the sewage can be released to the original line without requiring personnel to enter a manhole. The plug(s) shall be provided with an air line suitable for filling the plug from ground level and pressure gauge. The plugs shall also have a tag line. Flow through plugs may be employed to reduce flow into the pipe reach to be cleaned or inspected. These plugs must also be capable of having flow returned to the original pipe without personnel entering the manhole. Flow reduction operations must be completed during approved working hours for the location. Flow shall be restored to normal as soon as possible following flow reduction operations.
- B. Competent personnel shall monitor the flow reduction methods continuously. The personnel shall be able to readily recognize situations indicating imminent failure or potential spill. They shall operate and manage the equipment employed during the operation.
- C. A standby pump shall be provided and be on-site during non-pumping flow diversion operations. Pumping shall be done in such manner as will not damage property or create a nuisance or health menace. A standby pump is to be of suitable size to handle current pipe flows plus an additional one-hundred (100) percent. Standby pumps shall have pipe fittings installed to provide an immediate installation to take over from non-pumping flow diversion methods should the situation require it.
- D. Flow shall be restored to normal as soon as possible following flow reduction operations. Equipment shall be broken down in a manner to prevent any sewage from spilling

1.10 FLOW CONTROL WITH BYPASS PUMPING

- A. Bypass pumping and pumped removal of water in the pipelines may be necessary for the cleaning of pipelines with sags or minimal slope. Bypass pumping or pumped removal of water shall be required when the water depth is greater than one-third (1/3) the pipe diameter for more than one-half (1/2) the length of the pipeline segment.
- B. Bypass pumping may be required during cleaning to prevent surcharge and possible overflow of the sewer system. Bypass pumping may be required to allow immediate CCTV inspection prior to allowing waste to enter the pipeline. Contractor shall complete a

prior assessment of the existing sewer flows and provide an appraisal to the Park POC of any required bypass pumping activities at a minimum of one week prior to the need.

- C. The pumping system shall be of sufficient capacity to handle existing flow plus additional flow that may occur during a rainstorm. If pumping is required on a twenty-four (24) hour basis and engine drives are required, engines shall be equipped in a manner to keep noise to a minimum.
- D. Competent personnel shall monitor the bypass pumping operation continuously at all times the pumps are in place. If the operation extends beyond designated working hours, the competent person shall remain on-site at all times. The personnel shall be able to readily recognize situations indicating imminent failure or potential spill and be able capable of notifying authorities of the need for immediate action. They shall operate and manage the equipment employed during the operation. The designated competent person shall have no other duties than to manage the bypass pumping operation.
- E. Engine driven bypass pumping in residential areas shall not be permitted on a twenty-four (24) hour basis. Work must be coordinated to be completed during regular daytime operating hours.
- F. Two (2) standby pumps, equal in size and capacity to the approved bypass pump shall be provided and be on-site during bypass pumping operations. Standby pumps shall have pipe fittings installed to provide an immediate conversion from the disabled pump to the standby pump.
- G. Flow shall be restored to normal as soon as possible following bypass pumping. Equipment shall be broken down in a manner to prevent any sewage from spilling.

1.11 CLEANING

- A. Set-up for cleaning operations shall be in accordance with the approved Spill Prevention and Response Plan as amended for the specific site to be cleaned.
- B. The sewer cleaning setup shall be configured to allow the retention and removal of all rocks, gravel, pipe fragments, root cuttings, and heavy debris for disposal at an approved landfill.
- C. Sewer line cleaning shall be by use of a high pressure jetting head in combination with a vacuum truck for removal of solids and debris. High pressure jetting only may be allowed with approved debris catching equipment installed in the manhole immediately downstream of the pipe segment being cleaned. Moving solids and debris from one manhole to another is not permitted. Multiple passes shall be used to thoroughly remove accumulated materials.
- D. A root cutting head shall be used if at any time the cleaning head cannot pass through a pipe due to roots. The root cutter is not required if the jetting operation can pass the entire length of the pipeline. If a root cutter is necessary it shall be passed through the pipeline a minimum of twice. Root cutter shall be capable of cleaning a four (4) inch pipeline and six (6) inch and larger pipelines with offset joints. Multiple passes with high pressure water may be required for pipelines with offset joints.

- E. Chain flail cutters are not to be used without prior approval of the Park POC.
- F. The post cleaning condition of the pipe shall be free of settled solids in the invert, accumulated solids on the pipe walls and service taps, and be in a condition to allow CCTV inspection without encountering waste that obstructs the inspection. Failure to sufficiently clean the pipeline prior to CCTV inspection will result in the re-cleaning and inspection of the affected pipeline at no additional cost to the Government.

1.12 SOLIDS REMOVAL

- A. The Contractor shall collect and remove all solids produced during cleaning as follows:
 - 1. Remove all rock, sand and gravel debris collected during cleaning. Report any rocks three-fourths (3/4) inch and larger in the weekly log of cleaning observations.
 - 2. Report all pipe segments, pieces or other structural elements collected during cleaning in the weekly log of cleaning observations.
 - 3. Clean and remove all material in the manholes including in the channel, on the bench, and on the walls.

1.13 PERMANENT PLUGS

- A. Existing permanent plugs may be found in the pipelines during cleaning. The plugs have been constructed over the years to abandon pipelines. Records of their true location are not up to date. Record the location of all found plugs during cleaning operations in the weekly log. Verify plug locations in CCTV work.

1.14 WEEKLY LOG AND RECORD DRAWINGS

- A. The information discovered during cleaning regarding obstructions, heavy roots, grease, and plugged and abandoned lines will be very useful to the Government. Weekly cleaning logs shall be maintained and reviewed with the Park POC. Record drawings shall be maintained and submitted at the end of the work.
- B. Weekly logs shall include the following information as a minimum.
 - 1. Starting date, ending date, number of days worked
 - 2. Number of feet cleaned per day
 - 3. Type and size of debris in line
 - 4. Number of feet requiring root cutting
 - 5. Location of any obstructions
 - 6. Location of any abandoned lines and confirmation of abandonment plug location
 - 7. Special observations such as heavy rock debris, heavy grease, pipe pieces retrieved, etc. These special observations shall be highlighted in the weekly reports. Any obstructions remaining following cleaning shall be recorded as defects on the CCTV inspection forms per Section 02 53 40 – Closed Circuit Television (CCTV) Inspection.

C. Record Drawings

1. Marked up contract maps depicting any field observations made during cleaning operations as to location of immediate hazards such as heavy debris, broken pipe, rocks, or other useful information. Record Drawings shall have critical observations clearly marked by hand in RED INK. Record Drawings are to be maintained per pipe segment cleaned. Annotations shall be brief and consistent; for example;
 - a. Heavy roots cut during cleaning in segment A1-A2
 - b. Pipe pieces removed during cleaning in segment B23-B23A
 - c. Bypass pumping required during cleaning in segments A6-A7-A8-A9

END OF SECTION

SECTION 02 53 30

MANHOLE CLEANING & INSPECTION

PART 1 – GENERAL

1.1 SUMMARY

- A. Contractor shall perform a complete inspection and photo documentation of all manholes and related wastewater utility vaults in the assigned work area. The work includes a visual pre-cleaning inspection to document conditions that could be removed during cleaning of the manhole when necessary and follow up with a post-cleaning visual inspection. The documentation will be completed in accordance with the National Association of Sewer Service Companies (NASSCO) standards for manhole condition assessments (MACP®). Manholes will be inspected and their condition documented through completion of the database entries and still photos.

1.2 SUBMITTALS

- A. Submit the following
 - 1. Sample Manhole Inspection Form; NPS may add or delete header fields as needed for the project
 - 2. Manhole Inspection Health and Safety Plan (part of Company Safety Plan)
 - 3. Weekly draft inspection reports
 - 4. Printed hard copy and electronic copy of photographic image records (see Part 3)
- B. Inspection reports shall be compiled in numerical order, placed in high quality three ring binders, and submitted in triplicate to the NPS Project Manager and Park POC upon completion of the Work. Inspection reports shall include the Manhole Inspection Form and hard copy of photographic records for each manhole. Photographic records shall be high color computer generated original prints, maximum four (4) per sheet, three and one-half by five (3.5 x 5) inches approximate size. Thumbnail sized prints are not acceptable. See Section 01 78 50 – Deliverables.
- C. Record Drawings depicting any field observations as to location, identification, numbering, or other useful information shall be submitted at the completion of the Work. Record Drawings shall be the Contract Drawings with observations clearly marked by hand in RED INK.

1.3 MANHOLE NUMBERING AND LOCATION CONFIRMATION

- A. The Government numbering system for manholes shall be the basis for recording and logging all information. Contractor shall notify the Park POC of any manholes not having an assigned number. In consultation with the Park POC, Contractor shall provide a preliminary number in accordance with the numbering scheme in place for the work location.

- B. The Contractor shall locate the existing manholes and confirm access for inspection. The minimum effort required is as follows:
 - 1. Open the adjacent manhole and determine the bearing of the pipeline leading to the manhole to be located and measure off the distance shown on the Drawings to establish the suspected existing manhole location.
 - 2. Employ a pipe locator or metal detector with the capacity to audibly register a buried manhole lid at a depth of three (3) feet. Contractor shall survey an area approximately fifty (50) feet in diameter centered on the suspected existing manhole location.
 - 3. When unable to locate a manhole, stake the suspected existing manhole location with wood lath with the top four (4) inches painted surveyor's fluorescent green. Mark the lath with the manhole number using a wide tip black permanent ink pen.
 - 4. Mark location of the manhole not found on the Drawings and notify the Park POC for assistance in locating.
 - 5. The Contractor may, for his own convenience, stake manholes with the green top lath for future reference during CCTV work. Contractor shall retrieve all lath used and dispose of as construction debris once the pipeline has been inspected.
- C. The NPS shall locate existing manholes not found by the Contractor following the efforts described above. The Contractor shall proceed with his inspections and failure by the NPS to locate an existing manhole shall not relieve the Contractor from completing the inspection of all located manholes.
- D. Manholes located during the pipeline CCTV work shall be documented and their location staked with a green top wood lath with the new manhole number written on it and text indicating a "new" manhole. This stake shall not be removed until the NPS has the manhole location surveyed. (See Section 02 53 40 – Closed Circuit Television (CCTV) Inspection)

1.4 MANHOLE LID REMOVAL AND REPLACEMENT

- A. The ground around the manhole cover shall be cleared back a minimum of six (6) inches all around the cover prior to opening. Material shall be raked neatly to the side and spread to avoid the appearance of an excavation.
- B. The contractor shall notify the government when access into a bolt-down manhole is required. The contractor shall obtain written authorization from the Park POC before opening a bolt-down manhole.
- C. Before opening a bolt-down manhole the contractor shall have on hand, spill clean up equipment necessary for a minor spill. Any sewage issuing from the top of a bolt-down manhole should have the manhole lid reinstalled immediately and the spill cleaned up. The Park POC shall be notified immediately of this spill.
- D. Once open, if present, the PVC infiltration insert lid shall be removed, cleaned and inspected for cracks and replaced at no cost to the NPS if damaged by the contractor. Document on the manhole inspection forms the presence of, the measured diameter and the condition of any infiltration insert lids. Reinstall any PVC infiltration insert lids at completion of the cleaning and/or inspection.

- E. Report any manhole with excessive debris accumulation in the manhole or residing on the PVC infiltration insert lid. This may constitute a hazard that should be addressed by the NPS immediately.
- F. The frame, PVC infiltration insert lid and cover shall be cleaned prior to re-closure to provide a tight fitting installation.
- G. Contractor shall paint a one (1) inch diameter green circle on the edge of the manhole cover once the inspection is complete. Use typical utility marking paint for upside down application. Circle shall be neat with a solid green infill. Sloppy paint work shall be removed by the contractor and the cover repainted as directed by the Park POC.

1.5 FLOW CONTROL

- A. It is anticipated that manhole inspections will not require flow control to observe the manhole bench, channel, and piping entering and leaving the manhole.
- B. The Contractor shall make all accessible observations and measurements if the manhole is surcharged or passing sufficient flow as to restrict a complete inspection. The Contractor shall notify the Park POC of any manholes either surcharged or passing sufficient flows as to obstruct the inspection effort.

1.6 MANHOLE CLEANING

- A. Manholes should not be cleaned prior to inspection. Soil streaks, water stains, etc are indicators of infiltration and are to be documented and photographed during the inspection.
- B. If the manhole bench, walls or channels have too much debris to allow a thorough inspection, cleaning will be required as follows.
 - 1. Using a wide spray nozzle, with a high velocity, truck mounted vacuum tube in the manhole, wash down the manhole interior walls. All debris should be removed to allow for clean visual inspection of the manhole interior. Do not allow debris from the manhole to flow down the pipeline.
 - 2. Remove all debris that may be loaded on the bench or in the channel by vacuuming. Do not allow debris from the manhole to flow down the pipeline.

1.7 MANHOLE INSPECTION

- A. The Contractor shall conduct a structural inspection as follows:
 - 1. Inspect manhole frame, cover, grade rings, and cone for materials of construction, alignment (offset), structural condition, roots, signs of infiltration, and depth from rim to top of cone (chimney depth). Flag all manholes with a chimney depth exceeding twenty-four (24) inches and with a total depth exceeding four (4) feet on the inspection report form.
 - 2. Inspect the barrel (wall) for construction materials, diameter, offset, roots, inflow and infiltration and access rungs. Flag all manholes with less than four (4) feet nominal diameter, on the inspection report form.

3. Built-in access ladder rungs are to be documented but are not to be given a condition rating. Safe anchorage cannot be determined by visual inspection and therefore the data cannot be considered reliable. Flag all manholes with built-in access ladder rungs on the inspection report form.
4. Inspect bench and channel for materials of construction, condition, grease, debris, and corrosion. Flag on the inspection report form and report all manholes with channel and debris accumulation on the bench or obstructing flow. This may constitute an Immediate Hazard that should be addressed by the NPS immediately.
5. Measure and record depth to the nearest one-eighth (1/8) inch or 0.05 feet from the frame rim to invert at the center of the manhole. Use straightedge across manhole to get accurate measurement at center. If the manhole has extreme fall across the diameter, record the invert of all pipes penetrating the manhole. Include apparent size and direction of flow.
6. If any pipe penetrates a manhole at elevation above the manhole bottom then invert depths shall be measured for those pipe penetrations. Include invert measurements for both the upper and lower inlets of external drop connections at the point of entry to the manhole Record drop connections and identify as internal drop or external drop inlets.
7. An internal drop inlet shall be defined as any pipe entering the manhole at more that twelve (12) inches above the bench. All internal drop inlets greater that twenty-four (24) inches above the bench should be equipped with a drop pipe secured to the wall. Flag all internal drop inlets greater than twenty-four (24) inches not equipped with a secure drop pipe on the inspection report form.
8. An external drop inlet is identified by two same size wall penetrations aligned vertically, on top of the other. The upper penetration typically has a partial dam across the pipe to force low flows to travel through the drop pipe located outside the manhole. CCTV camera inspection may be necessary to identify an external drop.
9. All observations shall be recorded on a NASSCO approved manhole inspection form with an entry line for each component. The NPS reserves the right to review and modify as necessary the data entry form to provide the needed information. Entries shall be printed and legible. Inspection form shall include a drawn diagram plan view of the manhole for recording observations. Mark and number on the plan view all pipe penetrations. Record pipe sizes, direction of flow (In / Out), and observations using the assigned pipe numbering shown in the plan view diagram. Clearly mark the North direction in the plan view diagram. Plan view is to be drawn as per NASSCO guidelines with the outlet line at the six (6) o'clock position. Each pipe is to be numbered in a clockwise order with the outlet pipe being Pipe #1. Pipes directly above one another shall be numbered consecutively with the upper pipe having the lower number.

1.8 MANHOLE DIGITAL IMAGE RECORDS

- A. Each manhole shall have a minimum of two (2) digital photographic image records made. One (1) image shall show the rim, chimney and upper portions of the manhole. The second image shall show the interior of the manhole including the barrel, bench and channel. Interior image shall be taken sufficiently close to the rim to eliminate high contrast from the outside light and shall clearly show the inside of the manhole. Additional images shall be taken as necessary to show specific existing conditions not visible in the first two (2) images.

- B. Digital image shall have a minimum 1,024 x 768 pixel resolution and shall be saved in jpeg format.
- C. The file name shall be “manhole_id_date_of_photo_photo_sequence_number.jpg”. (A2_031708_002.jpg)
- D. Two (2), color, high resolution quality photograph sets shall be provided by the Contractor with no more than one (1) manhole per page showing up to four (4) images per eight and one-half by eleven (8-1/2” x 11”) inch page. See Section 01 78 50 – Deliverables.

1.9 PERMANENT PLUGS

- A. Existing permanent plugs may be found when inspecting the manholes. Record all found plugs. All existing plugs should be watertight and capable of withstanding all internal and external pressures without leakage. Record the location and condition of all plugs found. Report any unsound plug immediately to the government.

1.10 FINAL REPORT

- A. Manhole inspection reports shall be compiled in alpha/numeric order, placed in high quality three ring binders, and submitted in duplicate to the NPS upon completion of the work. Inspection reports shall include the Manhole Inspection Form, printed copy of manhole photographic records and printed copy of photographic records for each unusual condition and other pertinent defect. Photographic records shall be high contrast color, computer generated original prints, one (1) manhole per sheet and four (4) photos per sheet maximum. See Section 01 78 50 – Deliverables.
- B. Record Drawings depicting any field observations as to location, identification, numbering, or other useful information shall be submitted at the completion of the work. Record Drawings shall be the Contract Drawings with observations clearly marked by hand in RED INK. Contractor shall submit one (1) copy of the marked up Record Drawings at the completion of the work.

END OF SECTION

SECTION 02 53 40

CLOSED CIRCUIT TELEVISION (CCTV) INSPECTION

PART 1 – GENERAL

1.1 SUMMARY

- A. Included in the section are the requirements for completing the Closed Circuit Television (CCTV) inspection of four (4) inch and larger sanitary sewer pipelines. Four (4) inch and larger service laterals are included in this project. This work includes data entry into an electronic database with photographic image capture and submittal of detailed and summary reports listing the findings of the inspection. This work may include bypass pumping and off peak work hours as required to complete the CCTV inspection. This work also includes the implementation of a site specific Spill Prevention & Response Plan (SPRP) completed as part of specifications Section 01 35 50 - Resources Protection.

1.2 SUBMITTALS

- A. Submit the following
 - 1. Sample CCTV Inspection Form; NPS may add or delete header fields as needed for the project. The Inspection Form headers may be revised or adjusted as needed for different Park areas. The form headers will be approved prior to starting each Park but will not be modified while working at a Park.
 - 2. Weekly summary inspection reports that must include segment reports and a summary totaling the work done each week
 - 3. Weekly schedule and inspection plan.

1.3 RELATED DOCUMENTS

- A. Section 01 35 50 - Resources Protection
- B. Section 01 78 50 - Deliverables
- C. Section 02 50 10 - Testing of Sewer Force Mains & Appurtenances
- D. Section 02 53 30 - Manhole Cleaning & Inspection
- E. NASSCO Code Charts

1.4 GENERAL INFORMATION

- A. Notification of Immediate Hazards: Contractor shall notify the Park POC of any immediate hazard. Notification shall be verbal and immediate when there is a risk of a potential spill and the Spill Prevention Plan measures shall continue until the NPS releases the Contractor of site control. Immediate hazards which shall be reported include severely fractured pipes,

missing pipes segments, severe offset joints, and severe roots or grease. See paragraph 3.4 below.

- B. Record Drawings shall be maintained in the field depicting the following field observations.
 - 1. Show pipe diameter and apparent material of construction.
 - 2. Show manhole numbering
 - 3. Show pipeline flow direction
 - 4. Show location of immediate hazards
 - 5. Other pipe intersections
 - 6. Location and size of laterals
 - 7. Location of pipeline plugs

1.5 MANHOLE NUMBERING AND PIPE SEGMENT IDENTIFICATION

- A. The Government numbering system for manholes and/or cleanouts and termination points shall be the basis for recording and logging all information. Contractor shall notify the Park POC of any manholes not having an assigned number and shall provide a preliminary number in accordance with the numbering scheme in place for the specific work location.
- B. The Contractor shall locate the existing manholes and confirm access for inspection. The minimum effort required may be as follows:
 - 1. Open the adjacent manhole and determine the bearing of the pipeline leading to the manhole to be located and measure off the distance shown on the Drawings to establish the suspected existing manhole location.
 - 2. Employ a pipe locator or metal detector with the capacity to audibly register a buried manhole lid at a depth of three (3) feet. Contractor shall survey an area approximately fifty (50) feet in diameter centered on the suspected existing manhole location.
 - 3. When unable to locate a manhole, stake the suspected existing manhole location with wood lath with the top four (4) inches painted surveyor's fluorescent green. Mark the lath with the manhole number using a wide tip black permanent ink pen.
 - 4. Mark apparent location of the manhole not found on the drawings, and notify the Park POC for assistance in locating.
 - 5. The Contractor may, for his own convenience, stake manholes with the green top lath for future reference during CCTV work. Contractor shall retrieve all lath used and dispose of as construction debris once the pipeline has been inspected.
- C. The NPS shall locate existing manholes not found by the Contractor following the efforts described above. The Contractor shall proceed with his inspections and failure by the NPS to locate an existing manhole shall not relieve the Contractor from completing the inspection of all located manholes.
- D. Manholes located during the pipeline CCTV work shall be documented and their location staked with a green top wood lath with the new manhole number written on it and text indicating a "new" manhole. This stake shall not be removed until the Contractor has surveyed the manhole using sub-meter accurate GPS equipment or other approved surveying equipment.

1.6 SURVEY

- A. Newly found manholes or other system features require surveying to determine their exact location. The Contractor shall survey the points using sub-meter accurate GPS equipment or conventional land survey instruments. Survey location is to be included on marked up Record Drawings.
- B. Contractor may elect to use “office” location methods by accurately locating the new features and inserting them into accurately scaled, geo-referenced drawings.
- C. All latitude and longitude survey data is to be recorded regardless of the method used to locate the newly found features.

1.7 MANHOLE CLOSURE AND MARKING

- A. All existing manholes should be equipped with a solid well fitting cast iron cover with no drain holes and may include a PVC infiltration insert lid beneath the cast iron cover. The Contractor shall secure the manhole infiltration insert lid and replace place the cast iron cover upon completion of CCTV inspection.
- B. Contractor shall mark the manhole cover with a one (1) inch diameter white circle or spot painted on top of the cover denoting manhole was accessed during CCTV work and related pipeline data was completed. Painting shall be neat. Use typical utility marking paint for upside down application. Sloppy painting may require removal and re-painting at no additional cost to the Government.

1.8 SERVICE LATERALS

- A. All service laterals, four (4) inch diameter and larger, are to be included in the work. All data gathered shall be incorporated into the same database as the main line inspections. Access to clean outs shall be limited to external building locations only. The Contractor is not expected to access basements, crawl spaces or other interior building locations.
- B. Cleanout plugs are notorious for breaking during opening. Arrange with the NPS prior to opening cleanouts, to have replacement plugs available. It shall be the responsibility of the NPS to provide replacement plugs as needed. Should a plug be impossible to open, document the condition.

1.9 PRESSURIZED GRAVITY MAIN INSPECTION

- A. Contractor shall inspect all pressure cleanout locations and air/vacuum release valves. A site specific spill prevention plan associated with opening the cleanout for inspection shall be completed prior to opening. These cleanouts are generally on steep pipelines and are subject to pressures during blockages or may be surcharged during normal operations. Any compromised, damaged or unsound cleanout, cleanout pipe, cleanout lid and cover shall be reported immediately to the Government with a recommendation for repair.

- B. Contractor shall coordinate the inspection schedule of these pipelines and the work may involve working either prior to or after the peak visitation hours or possibly peak visitation seasons to reduce flows in the pipeline.

1.10 PRESSURIZED FORCE MAIN INSPECTIONS

- A. See Section 02 50 10 for Force Main Inspection requirements
- B. Not all force mains are suitable for internal camera inspection. Many force mains only have access points at either end. Access points along the length of the force main may not exist. The force main may not be able to be drained or pumped out. Coordination with the Park POC and utility system operators is required prior to any operation that involves force mains.
- C. Force mains not suitable for internal camera inspections shall be pressure tested. Coordination with the Park POC is required for this entire process.
- D. Contractor shall be required to inspect all air/vacuum release valves.
- E. Contractor shall coordinate the inspection schedule of these force mains with the Park POC. The work may involve working either prior to or after the peak visitation hours or possibly peak visitation seasons to reduce flows in the pipeline.

PART 2 - PRODUCTS

2.1 CAMERA EQUIPMENT

- A. Service Lateral Camera: Service lateral camera shall be a self leveling push type or tractor mounted color camera with capability to negotiate a four (4) inch forty-five (45) degree bend. Camera shall be suitable for insertion through a four (4) inch clean out and shall have a two-hundred (200) foot range minimum.
- B. Main-line Camera: Main-line camera shall be a pan and tilt type tractor mounted color camera with three hundred-sixty (360) degree scan of the circumference and tilt to allow viewing up to one hundred-fifteen (115) degrees back from the axis of the camera. The camera shall meet the following performance criteria:
 - 1. Camera shall have built-in text display capability with date, time, footage count, manhole location and comments as a minimum.
 - 2. Camera shall be able to focus from one-half (1/2) inch to infinity and be equipped with remote focus, iris, and color balance. Camera shall have a 2.5-lux rating or better.
 - 3. Camera shall be waterproof and sealed. Any camera fogging from internal moisture shall be removed and replaced with a watertight, fog free camera.
 - 4. The Contractor shall provide a completely fog free CCTV record.
 - 5. Camera shall be equipped with sufficient cable to allow a minimum of one thousand (1000) linear feet of video inspection in a single run.

2.2 CAMERA TRANSPORT DRIVE

- A. The camera transport drive assembly shall be specifically manufactured for the pipe material and diameters being inspected. Drive unit may be track or wheel driven and shall have the capability to pull over one thousand (1000) feet of cable through a six (6) inch PVC pipeline. Four (4) inch mainlines shall be inspected with tractor mounted camera with four hundred (400) foot minimum range, but in no case less than the distance between the manholes to be inspected. Larger diameter main-line cameras shall have a one thousand (1000) foot minimum range.
- B. The drive unit shall have forward, reverse, and free wheel drive capability.
- C. Drive unit shall provide a distance counter for measuring the traveled distance based on the revolutions of the drive or other accurate counter mechanism. Distance shall be measured in both forward and reverse and shall be to the nearest 0.1 feet.

2.3 SOFTWARE REQUIREMENTS

- A. Software Requirements: Database records shall be submitted in Microsoft Access 2003 or later version. Camera software is to meet the latest NASSCO certified version requirements.

2.4 DIGITAL VIDEO DISK (DVD) FILES

- A. A complete set of all television records shall be submitted on Digital Video Disks (DVD) and on a USB 2.0 powered Portable Hard Drives. CCTV video files shall be provided in mpeg format. The Contractor shall provide one file for each manhole to manhole segment CCTV inspection. Each file shall be named and indexed to a data base of manhole/pipeline identifiers. Organization and naming of electronic files shall be approved by the Park POC and NPS Project Manager. See Section 01 78 50 – Deliverables.

2.5 HARD COPY PRINTED REPORTS

- A. Printed pipeline segment reports shall be prepared and made available to the Park POC weekly. The contractor shall prepare two complete sets of pipeline segment reports as part of the final deliverables. See Section 01 78 50 – Deliverables.

PART 3 - EXECUTION

3.1 CCTV SETUP

- A. CCTV setup shall be as described in the approved Spill Prevention and Response Plan (Specifications: Section 01 35 50) and shall include traffic control. Traffic Control shall include vehicular and pedestrian traffic.

- B. CCTV setup shall be within improved roadways, access roads or walkways whenever possible. Access to manholes within natural areas shall be approved by the Park POC prior to mobilization to the site. Access off road may require the use of plywood planking placed under all tires consisting of a minimum two (2) foot by eight (8) foot sheets, one and one-eighth (1-1/8) inch thick, placed one layer thick or two (2) each, minimum two by eight foot (2' x 8') sheets, five-eighths (5/8) inch thick, placed two (2) layers thick. Larger sheets may be required if vehicle is unable to stay on top of plywood. Aluminum, portable aircraft landing mats may be used in lieu of plywood. Planking shall be fully removed following vehicle passage and shall in no case be left in place more than forty-eight (48) hours. High flotation all-terrain vehicles with the camera setup may be used in lieu of planking if approved by the Park POC. See Section 01 35 50.
- C. Camera shall be inserted into the manhole or cleanout and the counter reset to the designated camera lens starting distance prior to beginning the inspection.
- D. CCTV inspection may proceed if the pipeline is flowing one-third (1/3) full or less. Flows in excess of one-third (1/3) may be allowed if the visibility and picture quality are good. CCTV inspection over one-third (1/3) full shall be at the approval of the Park POC and/or the NPS Project Manager.
- E. The Contractor shall bypass pump and evacuate the pipeline if surcharged prior to inspecting. Contractor may reduce flows or divert flows as per below. Contractor shall adjust work hours to correspond with periods of low flow.

3.2 FLOW CONTROL WITHOUT PUMPING

- A. Divert sewage flows and storm water around all sewer cleaning areas as needed. Depth of flow shall be limited to one-third (1/3) or less of the diameter of the pipe for inspection. If flow is greater than one-third (1/3) the diameter of the pipe, the CCTV work shall be postponed for more favorable conditions or non-pumping flow control methods may be employed. Furnish, install, and manage plugs, conduits, and other equipment to lessen or divert the flow of sewage through or around the pipeline reach in which work is to be performed. Pneumatic plugs shall be designed so that all or any portion of the sewage can be released to the original line without requiring personnel to enter a manhole. The plug(s) shall be provided with an air line suitable for filling the plug from ground level and include a pressure gauge. The plugs shall also have a tag line. Flow through plugs may be employed to reduce flow into the pipe reach to be cleaned or inspected. These plugs must also be capable of having flow returned to the original pipe without personnel entering the manhole. Flow reduction operations must be completed during approved working hours for the location. Flow shall be restored to normal as soon as possible following flow reduction operations.
- B. Competent personnel shall monitor the flow control methods continuously. The personnel shall be able to readily recognize situations indicating imminent failure or potential spill. They shall operate and manage the equipment employed during the operation.

- C. A standby pump shall be provided and be on-site during non-pumping flow diversion operations. Pumping shall be done in such manner as will not damage property or create a nuisance or health menace. A standby pump is to be of suitable size to handle current pipe flows plus an additional one-hundred (100) percent. Standby pumps shall have pipe fittings installed to provide an immediate installation to take over from non-pumping flow diversion methods should the situation require it.
- D. Flow shall be restored to normal as soon as possible following flow reduction operations. Equipment shall be broken down in a manner to prevent any sewage from spilling.

3.3 FLOW CONTROL WITH BYPASS PUMPING

- A. Bypass pumping and/or pumped removal of water in the pipelines may be necessary for the inspection of pipelines with sags, minimal slope and/or high volume flow. Bypass pumping or pumped removal of water shall be required when the water depth is greater than one-third ($1/3$) the pipe diameter for more than one-half ($1/2$) the length of the pipeline segment.
- B. Bypass pumping may be required during inspection to prevent surcharge and possible overflow of the sewer system. Bypass pumping may be required following cleaning to allow immediate CCTV inspection prior to allowing waste to enter the pipeline. Contractor shall complete a prior assessment of the existing sewer flows and provide an appraisal to the Park POC of any required bypass pumping activities at a minimum of one (1) week prior to the need. Bypass pumping shall be the least favorable method of flow reduction for the CCTV inspection. Exhaust all alternatives before using bypass pumping.
- C. The pumping system shall be of sufficient capacity to handle existing flow plus additional flow that may occur during a rainstorm. If pumping is required on a twenty-four (24) hour basis and engine drives are required, engines shall be equipped in a manner to keep noise to a minimum.
- D. Competent personnel shall monitor the bypass pumping operation continuously at all times the pumps are in place. If the operation extends beyond designated working hours, the competent person shall remain on-site at all times. The personnel shall be able to readily recognize situations indicating imminent failure or potential spill and be capable of notifying authorities of the need for immediate action. They shall operate and manage the equipment employed during the operation. The designated competent person shall have no other duties than to manage the bypass pumping operation.
- E. Engine driven bypass pumping in residential areas shall not be permitted on a twenty-four (24) hour basis. Work must be coordinated to be completed during regular daytime operating hours.
- F. Two (2) standby pumps, equal in size and capacity to the approved bypass pump(s) shall be provided and be on-site during bypass pumping operations. Standby pumps shall have pipe fittings installed to provide an immediate conversion from the disabled pump to the standby pump.

- G. Flow shall be restored to normal as soon as possible following bypass pumping. Equipment shall be broken down in a manner to prevent any sewage from spilling

3.4 CCTV OBSERVATIONS AND REPORTING CRITERIA

- A. Contractor shall start each inspection with a verbal narrative of the manhole location, number and condition, as well as the date, time and any special circumstances associated with the specific location being inspected. Text with the same data shall be imprinted on the digital video file at the beginning of each run. The use of push cameras shall be limited to four (4) inch laterals and special conditions where a larger self-propelled camera cannot navigate the system. Obtain prior approval for special considerations for using a push camera. Failure to obtain prior approval of the Park POC or NPS Project Manager for use of a push type camera may result in rejection and re-inspection at no additional cost to the Government.
- B. The Contractor shall proceed down the pipeline at a speed not to exceed thirty (30) feet per minute or six (6) inches per second. The footage counter shall be a combined count using both a cable length and the traction drive distance. The actual distance shall be a resolved distance between the two counters. The camera shall be extracted, reset and the inspection started again if the two methods of measuring the distance are more than one (1) foot per one-hundred (100) feet out of agreement. The NPS Project Manager or Park POC may waive this requirement if the Contractor can show accuracy with one counting system.
- C. Observation shall include all conditions identified in the latest edition of the NASSCO Manual of Sewer Condition Classification, which include but are not limited to pipe condition, grease build up, pipe tap condition, root obstruction level and water depth. See attached NASSCO Code Chart.
- D. The camera operator shall stop at all defects and changes in materials or conditions and pan and tilt as necessary to properly identify and document conditions. The operator shall follow all NASSCO PACP Code Chart abbreviations when documenting defects and changes in conditions. As a minimum, camera observations shall include close-ups of infiltration locations, taps of all types, longitudinal and circumferential cracks, roots, changes in materials, obstacles and deposits. Low points or sags shall be documented at the beginning of and the end of the sag.
- E. Observations shall be made verbally on the video and shall be recorded on the printed hard copy inspection report form. Location and rating shall be clearly marked on the form. Inappropriate language recorded on the tape shall be grounds for rejection and re-inspection at no additional cost to the Government.
- F. Camera shall be stopped and rotated to inspect all features listed above and to look up all service taps.
- G. Still image capture shall be obtained for all immediate hazard or unusual conditions notification locations and other pertinent defects. Hard copy still image photographic prints of immediate hazards or unusual conditions shall be submitted within two (2) working days of observation and included in the final deliverable manuals. Other pertinent defect photos shall be submitted as part of the final deliverables only. A minimum of one (1) still image per pipe segment representative of the line conditions shall be provided.

- H. Reverse set up and inspection shall be clearly documented showing the reason for using a reverse setup and identifying the location of the end of inspections from both upstream and downstream. Any reach inaccessible shall be identified and an estimate of the length included in the inspection narrative and reporting. All documentation shall clearly identify if and where a reverse setup has been used.
- I. Report apparent flow volume at all laterals if such flow appears to be clear water as from infiltration.

3.5 IMMEDIATE HAZARDS OR UNUSUAL CONDITIONS NOTIFICATION

- A. The following conditions shall be reported as an immediate hazard or unusual condition on a daily basis to the Park POC. Hard copy still image photographic prints of immediate hazards or unusual conditions shall be submitted within two working days of observation.
 - 1. Fracture, any descriptor
 - 2. Broken, any descriptor
 - 3. Collapsed, any descriptor
 - 4. Grease level "Medium" or worse, where the level could impede or distort flow
 - 5. Protruding tap blocking the passage of the camera or projecting 50% or more into the pipe
 - 6. Offset joints of one-fourth (1/4) to one-half (1/2) of the pipe wall thickness or more
 - 7. Offset joints disrupting flow exceeding one-fourth (1/4) of the pipe diameter
 - 8. Roots level "Medium" or worse
 - 9. Increase in water level depth from less than one-third (1/3) pipe diameter to one-half (1/2) pipe diameter or greater

3.6 PERMANENT PLUGS

- A. Existing permanent plugs may be found when inspecting the pipeline. Record all found plugs. All existing plugs should be watertight and capable of withstanding all internal and external pressures without leakage. Record the location and condition of all plugs found. Report any unsound plug immediately to the government.

3.7 ELECTRONIC DATABASE RECORDS

- A. Contractor shall prepare and maintain an electronic database of the inspection records and provide two (2) copies to the NPS upon completion of the work. See Section 01 78 50 - Deliverables.
- B. Contractor shall maintain in their files a complete copy of the electronic database of the CCTV inspection for each NPS area for a minimum of one (1) year. Contractor must be able to produce a complete set of hard copy reports from this electronic file.

3.8 FINAL REPORTS

- A. CCTV Inspection Reports shall be compiled in alpha/numeric order, placed in high quality three ring binders, and submitted in duplicate to the NPS upon completion of the work. See Section 01 78 50 for organization of final deliverables.
- B. Record Drawings shall be marked up to depict any field observations as to location, identification, numbering, or other useful information and shall be submitted at the completion of the work. Record Drawings shall be the maps produced either by others under a separate contract or through this contract with observations clearly marked by hand in RED INK. Contractor shall submit one (1) copy of the marked up Record Drawings at the completion of the work.

END OF SECTION

SECTION 11 31 11

WASTEWATER LIFT STATION

PART 1 – GENERAL

1.1 SUMMARY

- A. Furnish and provide all supervision, labor, materials, tools, equipment, and perform all operations for the construction of submersible type wastewater lift stations as specified herein or as indicated on the Drawings.

1.2 SUBMITTALS

- A. Submit shop drawings for materials to be installed or furnished under this section.
- B. Submit manufacturer's certification that pipe and fittings meet or exceed specified requirements including all requested test results and material identifications.
- C. Shop drawings and engineering data shall be submitted in accordance with the requirements of Section _____ – Submittals. [*to be inserted*]
- D. Provide operation and maintenance manuals in accordance with Section _____ – Operation & Maintenance Data. [*to be inserted*]

1.3 REFERENCES

- A. All work shall be completed in accordance to the Park Sewer Design Standards and Specifications.

PART 2 - PRODUCTS

2.1 MANUFACTURERS:

- A. Concrete Wet Well: Wet well shall be pre-cast concrete.
- B. Concrete Valve Vault: Valve vault shall be cast-in-place.
- C. Exterior Structure Joint Seals: All joints on channels and structures that will convey or contain wastewater shall have an exterior seal manhole surface at joints. (twelve (12) inch EZ- WRAP or approved equal).
- D. Interior Wastewater Structure Coating: Apply an epoxy resin interior coating to all interior surfaces of the wet well structure. The coating shall be a hydrocarbon resin modified epoxy polyamide (DEVTAR 5A, ICI Devoe High Performance Coatings or approved equal).

- E. Access Hatch: Access hatch for lift station wet well and valve vault shall have a one-fourth (1/4) inch thick, one-piece, mill finish, extruded aluminum channel frame, incorporating a continuous concrete anchor. A one and on-half (1-1/2) inches drainage coupling shall be located in the corner of the frame and connected to drainage pipe to remove stormwater. Hatch frame shall have on the inside a door-support ledge on two (2) sides. Hinges and all fastening hardware shall be T-316 stainless steel. Hatch door panel shall be reinforced to withstand a live load of the H-20 designation. Hatch door shall open to ninety (90) degrees and automatically lock with a T-316 stainless steel hold open arm with aluminum release handle. Door shall incorporate compression springs to assist the door opening. Door shall close flush with the frame. Stainless steel pressure locks shall be provided to work in conjunction with a one-fourth (1/4) inch (7mm) thick neoprene compression gasket, mounted to the under side of the door, to insure minimal water intrusion and/or odor resistance. Hatch shall have a T-316 stainless steel slam lock with removable key and have a non-corrosive handle. Hatch shall have a lifetime guarantee against defects in material and/or workmanship. (Halliday Products, Inc. or approved equal). It shall be the responsibility of the Contractor to ensure that the pump guide system is installed within the access hatch to allow the unrestricted removal of the pump unit.
- F. Carbon Filter Vent: UV resistant PVC vent housing with removal mushroom type weather cap. Vent shall have recharge carbon packages containing impregnated activated carbon for rapid absorption of odors. (CF4, Orenco Systems Incorporated or approved equal)
- G. Pipe:
1. PVC Pipe:
 - a. PVC pressure pipe and fittings all meet the requirements of AWWA C900 or C905, "Standard for Polyvinyl Chloride (PVC) Pressure Pipe for Water Distribution". The pipe shall be furnished in cast-iron pipe or approved equal outside diameters with rubber gasketed joints. Pressure class pipe meeting the requirements of DR 18 shall be furnished. Pipe shall be furnished in twenty (20) foot laying lengths.
 - b. PVC gravity pipe and fittings shall conform to ASTM D 3034 or ASTM F 679, with integral-bell gasketed joints. Rubber gaskets shall be factory installed and conform to ASTM F 477. Pipe joints shall conform to ASTM D 3212. Pipe shall be made of PVC plastic having a cell classification of 12454-B or 12364-B as defined in ASTM D 1784 and shall have SDR of 35 and minimum pipe stiffness of forty-six (46) psi according to ASTM D 2412. Pipe shall be installed in compliance with ASTM D 2321. Bedding material shall provide adequate and uniform support under the pipe.
 2. Ductile Iron Pipe:
 - a. Shall be designed in accordance with the latest revision of ANSI/AWWA C150/A21.50 for a minimum one-hundred (150) psi (or project requirements, whichever is greater) rated working pressure plus a one-hundred (100) psi surge allowance (if anticipated surge pressures are other than one-hundred (100) psi, the actual anticipated pressure should be used); a two to (2) one (1) factor of safety on the sum of working pressure plus surge pressure.
 - b. Ductile iron pipe shall be manufactured in the U.S.A. in accordance with the latest revision of ANSI/AWWA C151/A2151. Each pipe shall be subjected to a hydrostatic pressure test of at least five-hundred (500) psi at the point of manufacture.

- c. Pipe shall have standard asphaltic coating (one (1) mil thickness minimum) on the exterior. Pipe shall also have ceramic epoxy interior coating (forty (40) mils Protecto 401, Pacific States Cast Iron Pipe Co. or approved equal).
 - d. The class or nominal thickness, net weight without lining, and casting period shall be clearly marked on each length of pipe. Additionally, the manufacturer's mark, country where cast, year in which the pipe was produced, and the letters "DI" or "Ductile" shall be cast or stamped on the pipe.
 - e. All pipe shall be furnished with Push-on Type Joints, such as TytonR or FastiteR. Joints shall be in accordance with ANSI/AWWA C111/A21.11, of latest revision, and be furnished complete with all necessary accessories.
 - f. All above ground installed ductile iron piping shall be painted with a paint suitable for the application in the color selected by the Owner.
- H. Ball Check Valves: Ball Check Valves shall conform to AWWA C508 and shall be manufactured from gray cast iron meeting or exceeding ASTM Class 30. Check valve shall have flanges in accordance with ANSI B16.1 for Class 125 iron flanges. Iron flanges shall be flat faced. Check valve shall be designed to permit a clear waterway opening with the ball remaining out of the waterway during operation allowing the use of pipeline cleaning apparatus if necessary. A cleanout port shall be provided to permit access to the valve interior without having to remove the check valve from the pipeline. Fasteners shall be stainless steel. Ball shall be hollow iron with natural rubber cover. (ABS Type 408 or approved equal)
- I. Eccentric Plug Valve: Plug Valves shall be of the tight closing, resilient faced non-lubricating variety and shall be of eccentric design such that the valve's pressure member (plug) rises off the body seat contact area immediately upon shaft re-adaptation during the opening movement. Valves shall be drop-tight at the rated pressure (one hundred-seventy-five (175) psi through twelve (12) inch, one hundred-fifty (150) psi fourteen (14) inch and above) and shall be satisfactory for applications involving throttling service as well as frequent or infrequent on-off service. The valve closing member should rotate approximately ninety (90) degrees from the full-open to full-closed position and vice-versa. The valve body shall be constructed of cast iron (semi-steel) conforming to ASTM A 126, Class B. Valve shall have flanges in conformance with ANSI B16.1 for Class 125 iron flanges. Eccentric Plug Valves shall have a rectangular shaped port. Port areas for three (3) inch – twenty (20) inch valves shall be a minimum eighty (80) percent full pipe area. Valve seat surface shall be welded-in overlay, cylindrically shaped of not less than ninety (90) percent pure nickel. Seat area shall be raised, with raised area completely covered with weld to insure proper seat contact. The machined seat area shall be a minimum of .125" thick and .500" wide. The valve plug shall be constructed of cast iron (semi-steel) conforming to ASTM A126, Class B. The plug shall have a cylindrical seating surface that is offset from the center of the plug shafts. The plug shafts shall be integral. The entire plug shall be one-hundred (100) percent encapsulated with Buna-N rubber in all valve sizes. The rubber compound shall be approximately 70 (Shore A) durometer hardness. The rubber to metal bond must withstand seventy-five (75) lbs, pull under test procedure ASTM D- 429-73 Method B. Shaft bearings, upper and lower, shall be sleeve type metal bearings, sintered, oil impregnated and permanently lubricated Type 316 stainless steel. Thrust bearings shall be Nylatron. Plug valve shaft seals shall be on the multiple V-ring (Chevron) and shall be adjustable. All packing shall be replaceable without removing the bonnet or actuator and while the valve is in service. Shaft seals shall be made of Buna-N. Each valve shall be given a test against the seat at the full rated working pressure and a hydrostatic shell test at twice the rated working pressure. Certified copies of individual tests shall be submitted when requested. Certified copies of proof-of-design tests shall be

submitted upon request. All eccentric plug valves shall be Clow F5412 (Flanged) or approved equal.

- K. Flap Valves: Flap Valves shall be manufactured out of gray iron or ductile iron. Valve shall be furnished with standard neoprene seat mountings. Hinges pins shall be bronze. Flanges shall be faced and drilled to one hundred-twenty-five (125) pound standard. Valves shall be Series R-5004 by Neenah Foundry Company or approved equal.

PART 3 - EXECUTION

3.1 EXAMINATION

- A. Verify that site conditions are ready to receive the work of this section.
- B. Verify that excavations are to the required alignment and grade.
- C. Verify that trench conditions and shoring, sheeting, and bracing protect workers and meet the requirements of OSHA.
- D. Examine all materials delivered to the site for defects or damage and that it meets the requirements of the contract documents.
- E. Verify that electrical power is available and of the correct characteristics.

3.2 INSTALLATION

- A. Lift Stations:
 - 1. Construct new lift station, new pressure sewer main, new gravity sewer pipe in accordance with Park standards and specifications.
 - 2. Perform hydrostatic testing on lift station wet well. Any visual leakage will be cause for rejection. The hydrostatic test shall be completed prior to backfilling the structure and while all dewatering is still being performed.
 - a. Plug all inlets and outlets of the structure.
 - b. Fill structure with water (wastewater is not allowed) twenty-four (24) hours prior to the time of the test to permit normal absorption into the walls to occur.
 - c. Fill structure to within one (1) foot of the finish elevation.
 - d. Measure water level after a two (2) hour duration. An allowance of 0.025 gallon/hour for each one (1) feet of structure depth.
 - e. If test fails, repair and retest.
 - 3. Perform start-up of lift station in accordance to pump manufacturer's requirements.

END OF SECTION

SECTION 15 16 00

PUMPS

PART 1 – GENERAL

1.1 DESCRIPTION

- A. Furnish and provide all supervision, labor, materials, tools, equipment, and perform all operations as specified herein or as indicated on the Drawings for the complete installation, start-up, and testing of the equipment.

1.2 SUBMITTALS

- A. Shop drawings and engineering data shall be submitted in accordance with the requirements of General Requirements regarding Submittals.
- B. Provide operation and maintenance manuals in accordance with Section _____ – Operation & Maintenance Data. [*to be inserted*]

PART 2 - PRODUCTS

2.1 WASTEWATER SUBMERSIBLE PUMPS AND ACCESSORIES

- A. Contractor shall provide and install submersible non-clog wastewater pumps. The pumps shall be designed for continuous operating service and constructed to meet the intended service. The pump(s) shall be capable of handling raw unscreened sewage and other similar solids-laden fluids without clogging. The suction inlet shall have a waveform with the leading edge of the impeller overlapping the waveform. Should a textile or plastic sheet plug the inlet, the shearing action of the leading edge of the impeller against the wave form of the inlet will cut away enough of the material to clear the inlet. There shall be no need for personnel to enter the wet well in order to remove or reinstall the pump(s). The pump(s) shall be automatically connected to the discharge piping when lowered into place on a guide rail system, requiring no bolts, nuts or fasteners to effect sealing to the discharge connection.
- B. Pump Construction:
 - 1. Impeller: The impeller shall be made of erosion-resistant chilled gray cast iron and shall be of the semi-open, non-clogging, dynamically balanced single vane design capable of passing a the minimum specified diameter of spherical solids. The impeller shall have a slip fit onto the motor shaft and drive key and shall be fastened to the shaft by a stainless steel bolt.
 - 2. Pump Volute: The pump volute shall be made of gray cast iron with smooth internal surfaces free of rough spots or flashing. The volute shall have a centerline discharge.
 - 3. Self Cleaning Front Plate: The pump shall be equipped with a gray cast iron front plate, mounted to the volute with four stainless steel adjusting screws to permit close

tolerance adjustment between the front plate and impeller for maximum pump efficiency. The front plate shall be designed with a wave shaped inlet and an outward spiraling V-shaped groove on the side facing the impeller, to shred and force stringy solids outward from the impeller and through the pump discharge.

4. Mechanical Seals: Each pump shall be equipped with a tandem double mechanical seal. The oil chamber shall separate the pump from the motor and shall provide lubrication for the seals. Both the lower stationary seal face and rotating seal face shall be made of silicone carbide while the upper stationary seal shall be made of carbon and the rotating seal face of tool steel. Each stationary seal face shall be sealed with an O-Ring. The positively driven seal faces shall be held in place by individual independent springs. The seals shall require neither routine maintenance nor adjustment and shall not be damaged when the pump is run dry. When required, seal oil inspection shall be achieved without disassembly of the pump. The seal shall not require the pumped liquid as a lubricant.
5. Seal Failure Warning System: An electrical probe shall be provided in the oil chamber for detecting the presence of water. A solid-state device mounted in the pump control panel or in a separate enclosure shall send a low voltage, low amperage signal to the probe. If water enters the oil chamber, the probe shall close an electrical circuit and energize a warning light on the face of the control panel.
6. Shaft and Bearings: The pump shaft shall be made of stainless steel supported by a heavy duty lower double row ball bearing and an upper sealed single row ball bearing.
7. Motor: The pump motor shall be housed in an air filled watertight housing to provide good heat transfer. The motor shall be a NEMA design B suitable for continuous duty with moisture resistant Class F insulation rated for one hundred-fifty-five (155) degrees C. The motor shall be rated for Class 1, Division 1, Group D, explosion-proof, with a combined service factor of 1.15. Oil filled motors shall not be considered equal to the dry air filled type nor acceptable. Each phase of motor shall contain a bimetallic electro mechanical temperature monitor embedded in the motor windings. The monitors shall be connected in series and coupled to the control circuit of the pump control panel so as to shut the pump down should any one of the monitors detect high temperature. The temperature setting of the temperature monitors shall be one hundred-forty (140) degrees +/- C five (5) degrees C and shall automatically reset once the stator temperature returns to normal.
8. Power cables shall be sized according to NEC standards and of sufficient length to reach the junction box without splices. Power cables shall be of the Ozoflex or SO type construction suitable for submersion in sewage. Strain reliefs shall be provided at each cable entry into the pump.
9. O-Rings and Fasteners: All mating surfaces of the pump and motor shall be machined and fitted with Buna N O-Rings where watertight sealing is required. Sealing shall be accomplished by the proper fitting of the parts and not by compression or special torque requirements. All external screws and fasteners shall be made of stainless steel. All surfaces coming into contact with the liquid media, other than stainless steel, shall be protected by a corrosion resistant coating.
10. Mixer: Mixer shall be adequately sized to agitate a minimum of an eight (8) foot diameter wet well. Mixer shall be specified in accordance with pump manufacturer recommendations. Mixer shall mount to the pump, or pump discharge header. Mixer shall meet minimum specifications of an ABS Series RW 300 (use ABS RW300 model RW3021-A17 or approved equal) submersible mixer.

C. Lift Station Pump Accessories

1. Hoisting Cable: Hoisting Cable shall be Type 304 stainless steel strand cable with a minimum breaking strength of six thousand-four-hundred (6,400) lb.
2. Pump Guide: The pump guide shall consist of an upper guide holder and a two (2) inch diameter, stainless steel guide bar as per manufacturer. Each pump shall be provided with dual guide rails.
3. Fasteners: All fasteners for the hoisting cable and pump guide shall be stainless steel including, but not limited to, all anchor bolts and nuts
4. Ratings:
 - a. Rated Input Voltage: two hundred-forty (240) volts, open delta, three-phase, sixty (60) Hz.
 - b. Motor Nameplate Voltage: two hundred-forty (240) volts, open delta, three-phase, sixty (60) Hz.

D. Lift Station Pumps: [*to be inserted for project specific data*]

1. Quantity of pumps _____ installed
2. Maximum Design Capacity _____ gpm @ _____ ft TDH
3. Design Capacity _____ gpm @ _____ ft TDH
4. Minimum Efficiency @ Design Point _____ %
5. Maximum Speed _____ rpm
6. Design Motor HP _____ hp
7. Pump discharge Size _____ inch
8. Solid Passing 3 inch
9. Equivalent to _____ [*insert selected pump*]

E. Control Panel: See Section _____, Electrical Installation & Materials [*to be inserted*]

PART 3 - EXECUTION

3.1 EXAMINATION

- A. Verify that site conditions are ready to receive the work of this section.
- B. Verify that electrical power is available and of the correct characteristics.

3.2 INSTALLATION

- A. Install all components in accordance with the Drawing Plans and manufacturer's recommendations.
- B. Provide all accessories as required to install all system components in accordance with manufacturer's instructions.

- C. All pump equipment shall operate without sound or vibration which is abnormal for the type of equipment.
- D. Lift Station Pumps: The pump(s) shall automatically connect to discharge connections when lowered into place on a single guide rail system, requiring no bolts, nuts or fasteners to affect proper sealing. Each system shall consist of no more than one (1) guide rail supported at the top by an upper guide bracket and at the bottom by the discharge connection. The guide rail base shall be equipped with a vertical straightening vane which properly aligns the slot in the pump bracket and centers the pump just prior to final seating. Ease and quick removal of pumps from other than the vertical direction over the center of the pump shall be a requirement of the system.

PART 4 - WARRANTY:

4.1 EQUIPMENT

- A. The pump and motor shall be warranted for a period of two (2) full years after date of shipment.

END OF SECTION

YOSEMITE NATIONAL PARK UTILITIES BRANCH

SEWER SYSTEM MANAGEMENT PLAN EL PORTAL SANITARY SEWER SYSTEM (CS 5SSO10735)

6.0 OVERFLOW EMERGENCY RESPONSE PLAN

YOSEMITE NATIONAL PARK UTILITIES BRANCH

SEWER SYSTEM MANAGEMENT PLAN

EL PORTAL

SANITARY SEWER SYSTEM (CS 5SSO10735)

6.0 OVERFLOW EMERGENCY RESPONSE PLAN

The Overflow Emergency Response Plan (OERP) is a plan within the sewer system management plan (SSMP) that is designed to provide written guidance for the Yosemite National Park (YNP) staff to properly and effectively respond, contain, secure, and report sewer system overflows (SSOs) while minimizing environmental impacts that may be created from SSOs. Sewage overflows from Private Lateral Sewage Discharges (PLSD) are sewage discharges that are caused by blockages or other problems within a privately owned lateral and will be managed as an SSO.

The emergency response actions described in this OERP are to protect public health and the environment as required by the California State Water Resources Control Board (SWRCB) Order No. 2006-0003, Statewide General Discharge Requirements for Sanitary Sewer Systems. The SWRCB Order No. 2006-0003 requires the OERP to contain at least the following elements:

- (a) *Proper notification procedures so that the primary responders and regulatory agencies are informed of all SSOs in a timely manner;*
- (b) *A program to ensure appropriate response to all SSOs;*
- (c) *Procedures to ensure prompt notification to appropriate regulatory agencies and other potentially affected entities (e.g. health agencies, regional water boards, water suppliers, etc.) of all SSOs that potentially affect public health or reach the waters of the State in accordance with the Monitoring and Reporting Program. All SSOs shall be reported in accordance with the Monitoring and Reporting MRP, the California Water Code, other State Law, and other applicable Regional Water Board Waste Discharge Requirements or National Pollutant Discharge Elimination System (NPDES) permit requirements. The SSMP should identify the officials who will receive immediate notification;*
- (d) *Procedures to ensure that appropriate staff and contractor personnel are aware of and follow the Overflow Emergency Response Plan and are appropriately trained;*
- (e) *Procedures to address emergency operations, such as traffic and crowd control and other necessary response activities; and*

YOSEMITE NATIONAL PARK UTILITIES BRANCH

SEWER SYSTEM MANAGEMENT PLAN

EL PORTAL

SANITARY SEWER SYSTEM (CS 5SSO10735)

- (f) *A program to ensure that all reasonable steps are taken to contain untreated wastewater and prevent discharge of untreated wastewater to waters of the United States and to minimize or correct any adverse impact on the environment resulting from the SSOs, including such accelerated or additional monitoring as may be necessary to determine the nature and impact of the discharge.*

6.1 CALIFORNIA SPECIFIC NOTIFICATION AND REPORTING REQUIREMENTS

The SWRCB's Monitoring and Reporting Program (MRP) established spill or SSO monitoring, notification, reporting, and recordkeeping requirements for SWRCB Order No. 2006-0003. The MRP describes SSOs in three categories, based on the level of threat to public health and the environment. The category having the greatest threat to public health is a Category 1 SSO or spill that is defined as:

- 1) Equals or exceeds 1000 gallons spilled sewage; or
- 2) A discharge of sewage to a surface water and/or drainage channel; or
- 3) A discharge of sewage to a storm drain that was not fully captured and returned to the collection system.

A Category 2 SSO is defined as any sewage discharge that does not meet the criteria for a Category 1 SSO. A Private Lateral Sewage Discharge (PLSD) is a category of sewage discharge caused by blockages or other problems within privately owned laterals or collection systems which are tributary to the reporting Enrollee's sanitary sewer system. Reports of these events are submitted by Enrollees on a voluntary basis but are not their responsibility. This type of sewage discharge is the responsibility of the private lateral or collection system owner.² There are privately owned laterals within El Portal, i.e. Yosemite View Lodge. Therefore, this OERP for El Portal manages all SSOs as either Category 1 or Category 2 spills.

² Definition of PSLD

http://www.waterboards.ca.gov/water_issues/programs/academy/courses/sanitary_sewer_collection/so_glossary_july08.pdf

YOSEMITE NATIONAL PARK UTILITIES BRANCH

SEWER SYSTEM MANAGEMENT PLAN

EL PORTAL

SANITARY SEWER SYSTEM (CS 5SSO10735)

The MRP provides SSO reporting timeframes that consist of:

- Category 1 SSOs must be reported as soon as possible but no later than 3 business days.
- A final certified report for Category 1 SSOs must be completed within 15 calendar days
- All Category 2 SSOs must be reported within 30 days after the end of the calendar month in which the SSO occurs (e.g., all SSOs occurring in the month of January must be reported by March 1st)
- If there are no SSOs during the calendar month, a statement is submitted certifying that there were no SSOs for the designated month within 30 days after the end of each calendar month.
- The “Collection System Questionnaire” must be updated at least every 12 months.

The Utilities Branch has set up an SSO database account with the California Integrated Water Quality System (CIWQS) Online SSO Reporting System that is used for reporting SSO information to the SWRCB. In the event that CIWQS is not available, the Facilities Manager for the Utilities Branch or designee will fax all required information to the Fresno office of the Central Valley Regional Water Quality Control (CVRWQC) Board at 559-445-5116, attn: "District Supervisor", in accordance with the time schedules identified above for SSO reporting. Detailed El Portal SSO reporting requirements are presented in Section 6.4.

The initial mandatory report prior to finalizing and certifying an SSO report shall include the following minimum information:

- Location of SSO according to global positioning system (GPS) coordinates.
- Identify the region in which SSO occurred. El Portal is governed by the Central Valley Regional Water Quality Board.
- County where SSO occurred. El Portal is in Mariposa County.
- Describe whether or not the SSO entered a drainage channel and/or surface water.

YOSEMITE NATIONAL PARK UTILITIES BRANCH

SEWER SYSTEM MANAGEMENT PLAN

EL PORTAL

SANITARY SEWER SYSTEM (CS 5SSO10735)

- Describe whether or not the SSO was discharged to a storm drain pipe that was not fully captured and returned to the sanitary sewer system.
- Estimated SSO volume in gallons.
- SSO source (manhole, clean-out, etc.)
- SSO cause (mainline blockage, roots, etc.)
- Time of SSO notification or discovery.
- Estimated operator arrival time.
- SSO destination or expected to impact.
- Estimated SSO end time.
- SSO certification. Upon SSO certification, the SSO database will issue a final SSO identification number.

SSO notification and reporting requirements were updated with SWRCB Order No. WQ 2008-0002-EXEC, Adopted Amended Monitoring and Reporting Requirements for Statewide General Waste Discharge Requirements for Sanitary Sewer Systems, dated February 20, 2008, that states:

1. *For any discharges of sewage that results in a drainage to a drainage channel or a surface water, the Discharger shall, as soon as possible, but not later than 2 hours after becoming aware of the discharge, notify the State Office of Emergency Services (OES), the local health officer or directors of environmental health with jurisdiction over affected water bodies, and the appropriate Regional Water Quality Control Board.*
2. *As soon as possible, but no later than 24 hours after becoming aware of a discharge to a drainage channel or a surface water, the Discharger shall submit to the appropriate Regional Water Quality Board a certification that the State Office of Emergency Services and the local health officer or directors of environmental health with jurisdiction over the affected water bodies have been notified of the discharge.*

YOSEMITE NATIONAL PARK UTILITIES BRANCH

SEWER SYSTEM MANAGEMENT PLAN EL PORTAL SANITARY SEWER SYSTEM (CS 5SSO10735)

TABLE 6.1
Regulatory Agency Contacts for Sewage Spill Notifications
Within El Portal

Regulatory Agency	Telephone Contact Number
State Office of Emergency Services (OES) issues	1-800-852-7550 1-916-262-1621
Central Valley Regional Water Quality Control (CVRWQC) Board, (Region 5) attn: District Supervisor	1-559-445-5116
Mariposa County Health Department	1-209-966-2220
Note 1: Regulatory notification of YNP SSOs is accomplished by the Utilities Branch Supervisor or his/her designee as detailed in Section 6.4 below. The designee as of May 10, 2012 is Katie A. Brown, Facility Management Division, Facility Operations Specialist, (209) 379-1071	

Specific El Portal SSO or spill reporting requirements are presented in Section 6.4, recordkeeping requirements are presented in Section 6.5, and environmental monitoring requirements are presented in Section 6.3.2.B.

YOSEMITE NATIONAL PARK UTILITIES BRANCH

SEWER SYSTEM MANAGEMENT PLAN

EL PORTAL

SANITARY SEWER SYSTEM (CS 5SSO10735)

6.2 SSO DETECTION WITHIN EL PORTAL

SSOs within El Portal can be detected by NPS staff, lift station alarms, and/or public observations; but the majority of the SSOs are detected by USRO staff during daily sewer system inspections, as outlined in Section 4 of the SSMP. El Portal has seven operating sewer lift stations that pump wastewater from the sewer collection system to the wastewater treatment system. All seven lift stations have alarm capability through SCADA and local alarm lighting to indicate pump failures.

Daily sewer system inspections to include the lift stations by USRO staff are crucial for early detection of SSOs or system failures that may lead to an SSO. The discovery of sewer system conditions that may create an SSO will require USRO action, but the urgency of system repair(s) will be based upon the perceived threat of an SSO as jointly determined by the USRO staff and their supervisor. For example, non-emergency conditions would be handled with a work order issued by the Facility Management Software System (FMSS) Help Desk, but emergency conditions may require immediate deployment of labor and equipment resources from El Portal or Yosemite Valley maintenance yards.

6.3 EL PORTAL SSO RESPONSE

6.3.1 USRO RESPONSE

Sewer service calls and lift station alarms are considered high priority events that demand prompt USRO staff response. If an SSO occurs or is probable, the USRO staff will initiate the response measures described in Table 6.2 that includes: ascertain safe site access, attempt to stop the sewer overflow, restore normal pipe flow, and contain the sewage spill using the hand tools maintained in their service trucks or equipment staged at the local maintenance shop. The USRO supervisor will be immediately notified if an SSO is discovered and whether additional resources must be mobilized to either stop the SSO, restore sewer flow, contain the sewage spill, minimize environmental damage, or to clean-up or remediate the SSO site. The YNP dispatcher will also be contacted by the USRO staff to obtain a YNP incident number.

YOSEMITE NATIONAL PARK UTILITIES BRANCH

SEWER SYSTEM MANAGEMENT PLAN

EL PORTAL

SANITARY SEWER SYSTEM (CS 5SSO10735)

**TABLE 6.2
Emergency Response Checklist**

ENVIRONMENTAL IMPACTS	EMERGENCY RESPONSE MEASURES	
	USRO O&M Staff	USRO Supervisor
<p><u>SSO impacts surface water</u> from either direct stream discharge, or from potential storm drains, or from storm diversions</p> <p><u>SSO impacts ground surface</u> with no impacts to surface water</p>	<ol style="list-style-type: none"> 1. Ensure safe site access and stop the source, as soon as possible. 2. Divert sewer spill away from storm drain or surface water, as soon as possible, with drain covers, pipe plugs, dikes, sandbags, earthen berms, or other methods. 3. Notify USRO supervisor and initiate SSO reporting with USRO Supervisor and YNP Dispatch to obtain an incident number. Note Category 1: SSOs as defined in Section 6.1 must be reported within 2 hours after becoming aware of the unauthorized discharge. Spill reporting requirements are detailed in Section 6.4. Begin to prepare the Yosemite Utilities Branch SSO Report, Exhibit 6.1, with site-specific spill data and information. 	<ol style="list-style-type: none"> 1. Collect information from USRO staff. Provide labor and equipment resources as necessary to prevent environmental impacts. 2. Report SSO to Utilities Branch Management for regulatory reporting (see SSO reporting requirements in Section 6.4) and the YNP Dispatch to obtain an incident number. 3. Inspect site of SSO, if necessary. 4. Assess environmental impacts, need for surface water sample collection, and site clean-up requirements. <ol style="list-style-type: none"> a. Initiate sampling, if required. Water quality sampling and testing is required as sewage enters a water body.

YOSEMITE NATIONAL PARK UTILITIES BRANCH

SEWER SYSTEM MANAGEMENT PLAN

EL PORTAL

SANITARY SEWER SYSTEM (CS 5SSO10735)

**TABLE 6.2 (Continued)
Emergency Response Checklist**

ENVIRONMENTAL IMPACTS	EMERGENCY RESPONSE MEASURES	
	USRO O&M Staff	USRO Supervisor
	<p>Request for additional spill containment and site clean-up support resources as necessary, to minimize environmental impacts.</p> <p>4. Continue to prevent flow into surface waters with installation of portable pumps, piping, and earthen berms.</p> <p>5. Secure and cordon off spill area with markers, barricades, cones, signage, caution tape, fencing, and other controls necessary to restrict/prevent public access or contact with spilled sewage.</p> <p>6. Restore sewer flows by removing blockages and/or make appropriate system repairs that created or caused the SSO. Temporary repairs may be required if permanent repairs require engineering.</p> <p>7. Support environmental sampling as directed by USRO Supervisor. Spills discharged into water bodies will require coliform bacteria sampling.</p>	<p>(There are no de minimus values when environmental monitoring is required if a sewage spill enters a water body.) See Section 6.3.2.B for specific water quality monitoring requirements.</p> <p>b. Approve site clean-up plan to include clean-up methods and equipment/resource requirements (e.g. pumper truck, vacuum truck, front-end loader, dump truck, sweeper, additional laborers.)</p> <p>5. Jointly investigate with USRO Staff and Utilities Branch Management and determine corrective measures to prevent other SSOs at this location.</p>

YOSEMITE NATIONAL PARK UTILITIES BRANCH

SEWER SYSTEM MANAGEMENT PLAN

EL PORTAL

SANITARY SEWER SYSTEM (CS 5SSO10735)

**TABLE 6.2 (Continued)
Emergency Response Checklist**

ENVIRONMENTAL IMPACTS	EMERGENCY RESPONSE MEASURES	
	USRO O&M Staff	USRO Supervisor
	<ul style="list-style-type: none">8. Initiate site clean-up following USRO Supervisor concurrence. (Properly dispose of all wastes.)<ul style="list-style-type: none">a. Pump and/or vacuum liquidb. and solid sewage contaminants.c. Scoop and sweep remaining site sewage contaminants.d. Disinfect the area and allow the area to naturally dry, if possible.9. Final site clean-up to return the site to its original state.10. Investigate and determine long term solution to prevent further SSOs at this location.	

Spill size data and spill location requirements are discussed in Section 6.3.2 and the YNP specific format for SSO reporting is presented in Exhibit 6.1. Completion of Exhibit 6.1 is performed by the USRO staff and submitted to the Utilities Branch Facilities Manager or designee through the USRO supervisor. This information is then used by the Utilities Branch Facilities Manager or designee for final regulatory reporting and certification as reported in Section 6.4.

Wherever possible, the spill activities shall be documented using photos of the SSO site before and during the recovery operation. A hand held global positioning system (GPS) device should be used to document spill location along with street or nearest cross streets address. The USRO staff shall set up traffic and pedestrian controls as necessary to protect workers and the public. Creeks, streams, and drainage channels

YOSEMITE NATIONAL PARK UTILITIES BRANCH

SEWER SYSTEM MANAGEMENT PLAN

EL PORTAL

SANITARY SEWER SYSTEM (CS 5SSO10735)

that have been contaminated as a result of an SSO may need warning signs at visible access locations until the risk of contamination has subsided to acceptable background levels. However, Park Superintendent approval is required for all warning signs. The warning signs, example shown in Figure 6.1, should be checked every day to ensure that they are still in place. The warning signs should only be removed after the Utilities personnel determines the risk of contamination is to acceptable background levels.

Water quality sampling and testing is required whenever spilled sewage enters a water body to determine the extent and environmental impact resulting from the SSO. Environmental sampling is further detailed in Section 6.3.2.B. Any sewage spill having an off-color, chemical non-sewage odor or oily sheen may be contaminated with hazardous materials or chemicals and will require further environmental investigation to determine if the spill must be managed differently or as a hazardous material. Utilities Management staff should contact the Fire Department and the Safety, Health and Environmental Office for further immediate investigation if the conditions discussed above are apparent.

For large sewage spills or if the sewage spill is in an environmentally sensitive area, the USRO Staff will document conditions upon arrival with photographs and solicit support from the USRO Supervisor if blockage cannot be readily resolved and the sewage contained (within 15 minutes) or if sewer bypass is required. For small or moderately sized sewage spills, the USRO staff should proceed to clear the blockage to restore sewer flow and initiate sewage containment measures within the capabilities of the USRO field staff. Otherwise, the USRO Supervisor should provide additional support and resources necessary to address the SSO.

If the blockage cannot be cleared within a reasonable time (within 15 minutes) or the sewer requires construction repairs to restore flow, then sewage containment and/or sewer bypass pumping is necessary and should be requested from the USRO Supervisor. The recovery and clean up phase begins when the flow has been restored and the spilled sewage has been contained/returned to the sanitary sewer to the extent possible. The SSO recovery and clean up procedures include:

- Estimate the volume of spilled sewage,
- Estimate volume of recovery of spilled sewage, and
- Perform site clean-up or remediation and disinfection.

YOSEMITE NATIONAL PARK UTILITIES BRANCH

SEWER SYSTEM MANAGEMENT PLAN

EL PORTAL

SANITARY SEWER SYSTEM (CS 5SSO10735)

SSO recovery of spilled sewage will require a combination of vacuuming, pumping, and/or flushing the sewage back into the sewer collection system or wastewater treatment facility. If sewage has reached the storm drain system, the hydro-truck should be used to vacuum/pump out the catch basin and any other portion of the storm drain that may contain sewage. The operator should look for any signs of sewage solids and sewage-related material that may warrant additional cleanup activities. All signs of sewage solids and sewage-related material should be collected by hand or with the use of rakes and brooms. The affected area should be washed with clean water until the water runs clear. Reasonable steps should be taken to contain and vacuum up the wastewater and return it to the wastewater collection system. Disinfect all areas that were contaminated from the overflow using the disinfectant solution of household bleach diluted 10:1 with water or other approved disinfectant. Apply minimal amounts of the disinfectant solution using a hand sprayer. The flushing volume should be approximately three times the estimated volume of the spill. Either contain or vacuum up the wash water so that none is released. Return the wastewater to the wastewater collection system to the extent possible. Flushing and sampling during heavy storm precipitation events with heavy runoff may not be effective or have meaningful results; therefore, flushing and sampling may not be required during this climatic event.

The USRO staff, supervisor and Utilities Management should jointly investigate and determine corrective measures that will prevent reoccurrence of the SSO. See Section 6.6 Failure Analysis Investigation for historical information review requirements for determining potential corrective measures.

Each SSO event is an opportunity to evaluate the response and reporting procedures that includes challenges in securing the site, containing the spill, calculating spill volumes, determining the cause of the SSO, and other parameters. Therefore, the USRO supervisor should attempt to meet with the participants as soon as possible following each Category 1 SSO event, as defined in Section 6.2, to debrief and discuss the procedures employed to address the SSO. The results of the debriefing should be recorded and tracked to ensure any action items are completed. Refer to Section 6.8 for additional training and table-top exercises.

YOSEMITE NATIONAL PARK UTILITIES BRANCH

SEWER SYSTEM MANAGEMENT PLAN

EL PORTAL

SANITARY SEWER SYSTEM (CS 5SSO10735)

FIGURE 6.1
Signage for Spill Notification



YOSEMITE NATIONAL PARK UTILITIES BRANCH

SEWER SYSTEM MANAGEMENT PLAN

EL PORTAL

SANITARY SEWER SYSTEM (CS 5SSO10735)

6.3.2 USRO DATA COLLECTION

A. SPILL VOLUMES

Spill volumes can be estimated and reported using simple mathematical relationships to site spill facts, but the estimates should be documented, whenever possible, with photos of the SSO site during and after sewage recovery operations discussed below.

The volume of small spills can be estimated using an “eyeball estimate”. This method compares the spill volume to the amount of water that would spill from a bucket or a barrel, knowing that a bucket contains 5 gallons and a barrel contains 55 gallons. If the spill is larger than 55 gallons, break the standing water into barrels and then multiply by 55 gallons. This method is useful for contained spills up to approximately 4 barrels or 200 gallons.

Larger spill volumes that have been contained can be estimated by multiplying the depth and area of spill as outlined in the seven steps below:

- Step 1 Sketch the shape of the contained sewage.
- Step 2 Measure or pace off the dimensions.
- Step 3 Measure the depth at several locations and select an average.
- Step 4 Convert the dimensions, including depth, to feet.
- Step 5 Calculate the area in square feet using the following formulas:

Rectangle: Area = length (feet) x width (feet)

Circle: Area = diameter (feet) x diameter (feet) x 0.79

Triangle: Area = base (feet) x height (feet) x 0.5

- Step 6 Multiply the area (square feet) times the depth (in feet) to obtain the volume in cubic feet.
- Step 7 Multiply the volume in cubic feet by 7.5 to convert it to gallons.

YOSEMITE NATIONAL PARK UTILITIES BRANCH

SEWER SYSTEM MANAGEMENT PLAN

EL PORTAL

SANITARY SEWER SYSTEM (CS 5SSO10735)

Sewer volumes that have not been contained and are free flowing from a pipe, manhole, or other sewer appurtenance can be estimated in gallons by multiplying the sewer over flow in gallons per minute (eye ball method) by the estimated duration of sewer overflow in minutes. SSO flow volumes can be estimated using Figure 6.2 below during visual observation of sewer flow exiting from a manhole.

FIGURE 6.2
Flow Estimation Pictures

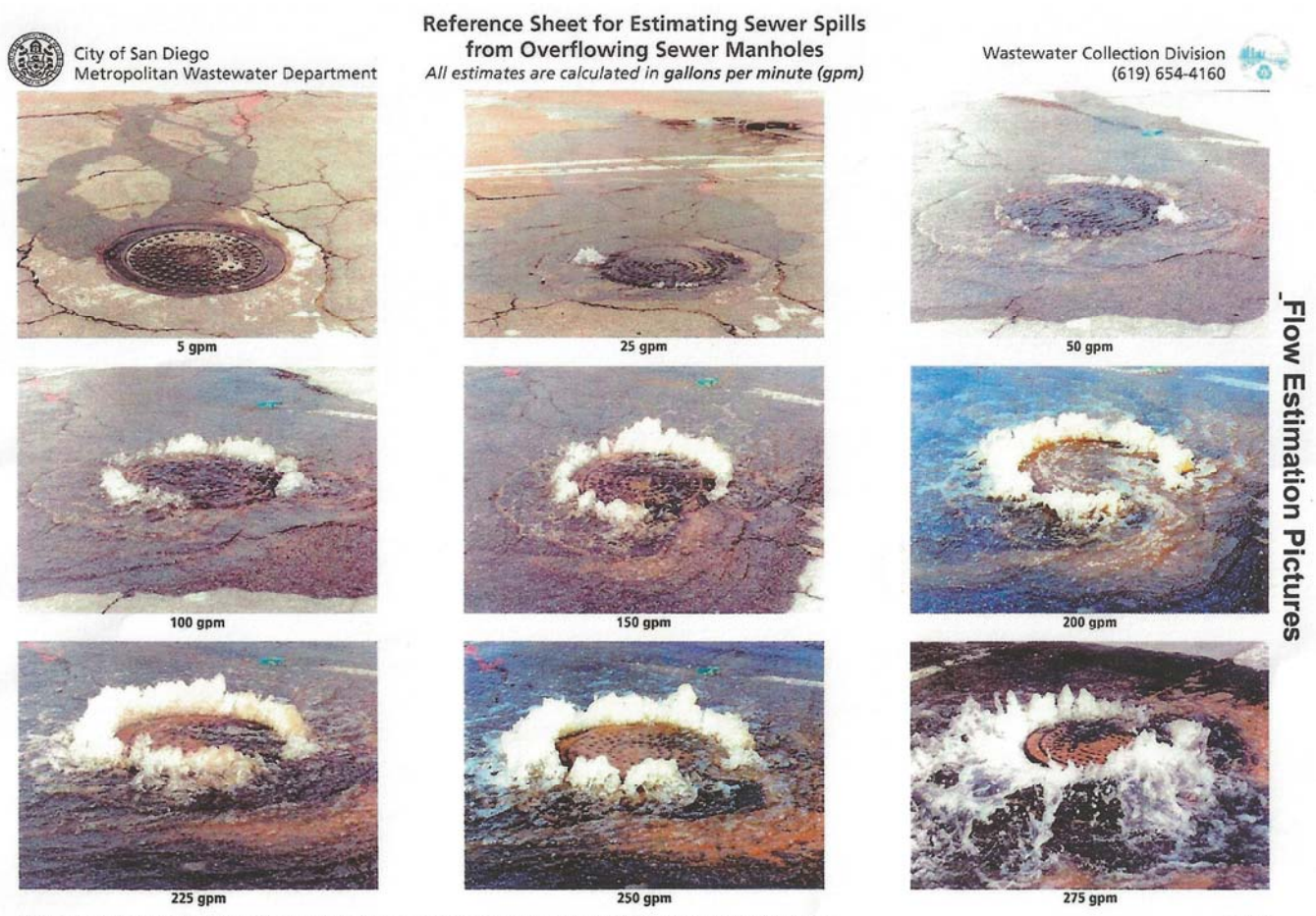

All photos were taken during a demonstration using metered water from a hydrant in cooperation with the City of San Diego's Water Department.

rev. 4/99

YOSEMITE NATIONAL PARK UTILITIES BRANCH

SEWER SYSTEM MANAGEMENT PLAN

EL PORTAL

SANITARY SEWER SYSTEM (CS 5SSO10735)

Additionally, any sewage volumes pumped or vacuumed from a spill can be directly measured or estimated by the equipment storage volume.

B. ENVIRONMENTAL SAMPLING

Water quality sampling should be collected as soon as possible after the discovery of the SSO event, but should not compromise SSO control, containment, and sewer flow restoration measures. For example, sampling may begin following small spills after the sewage has been contained and sewer flow has been restored, but larger SSOs may not allow the collection of environmental samples until additional personnel and resources arrive on-site.

In rivers or flowing water, the water quality samples should be collected upstream of the spill, from within the spill area, and downstream of the spill. In stationary water bodies, the water quality samples should be collected near the point of entry and every 100 to 200 feet along the shore of stationary water body for 1,000 feet. Additional shoreline sampling to include beyond 1,000 feet from the spill point of entry may be required if extensive surface water contamination is found. The determination of whether to perform additional sampling should be made by the Utilities Branch Facilities Manager or designee following consultation with the CVRWQC Board (District Supervisor at 559-445-5116).

Only regulatory approved labs using regulatory approved analytical procedures shall be used to analyze the water quality samples. The basic or primary water analyses should include at least total coliform and fecal coliform, but biochemical oxygen demand (BOD), dissolved oxygen, and ammonia nitrogen may be required for small stationary water bodies. Analytical data should contain at least the following:

- a. The date, exact place, and time of sampling or measurements;
- b. The individual(s) and laboratory who performed the sampling or measurements;
- c. The date(s) analyses were performed;
- d. The individual(s) who performed the analyses;
- e. The analytical technique or method used; and,
- f. The results of such analyses.

YOSEMITE NATIONAL PARK UTILITIES BRANCH

SEWER SYSTEM MANAGEMENT PLAN

EL PORTAL

SANITARY SEWER SYSTEM (CS 5SSO10735)

Regulatory agencies such as SWRCB and the California Department of Fish and Game may provide additional guidance for environmental sampling in sensitive environmental areas, following spill notification.

6.4 EL PORTAL SSO REPORTING REQUIREMENTS

The Facilities Manager or designee for the Utilities Branch is responsible for SSO regulatory reporting and the Park Superintendent is responsible for certifying all regulatory SSO reports. The Utilities Branch has set up an SSO database account with California Integrated Water Quality System (CIWQS) Online SSO Reporting System that is used for reporting SSO information to the SWRCB. In the event that CIWQS is not available, the Facilities Manager for the Utilities Branch or designee will fax all required information to the Fresno office of the Central Valley Regional Water Quality Control (CVRWQC) Board in accordance with the time schedules identified below for SSO reporting. The schedule for SSO reporting and certification is as follows:

1. 2-Hour Reporting Requirement
For any discharges of sewage that results in a discharge to a drainage channel or a surface water, the Facilities Manager or designee for the Utilities Branch shall, as soon as possible, but not later than 2 hours after becoming aware of the discharge, notify the OES, the Mariposa County Health Department, and the Fresno office of CVRWQC Board. See Table 6.1 for contact numbers. Other agency contacts shown in Exhibit 6.2 should be reviewed to determine if they need to be informed.
2. 24-Hour or 1 Day Reporting Requirement
No later than 24 hours after becoming aware of a discharge to a drainage channel or a surface water identified in item 1 above, the Park Superintendent shall submit to the CVRWQC Board a certification that the OES and the Mariposa County Health Department were notified.
3. 3-Day Reporting Requirement
Category 1 SSOs, as defined in Section 6.1, must be reported to the Online SSO System as soon as possible but no later than 3 business days with the following information:

YOSEMITE NATIONAL PARK UTILITIES BRANCH

SEWER SYSTEM MANAGEMENT PLAN

EL PORTAL

SANITARY SEWER SYSTEM (CS 5SSO10735)

- a. OES control number issued by OES when first notified (if applicable);
- b. Date OES was called (if applicable);
- c. Time OES was called (if applicable);
- d. Identify whether or not Mariposa County Health Department was called;
- e. Date Mariposa County Health Department was called (if applicable); and
- f. Time Mariposa County Health Department was called (if applicable)
- g. Location of SSO by entering GPS coordinates;
- h. Report what California Water Quality Control Board will govern the spill. (All SSOs within Yosemite National Park are governed by the Central Valley Regional Water Quality Control Board).
- i. County where SSO occurred; El Portal is within Mariposa County.
- j. Whether or not the SSO entered a drainage channel and/or surface water;
- k. Whether or not the SSO was discharged to a storm drain pipe that was not fully captured and returned to the sanitary sewer system
- l. Estimated SSO volume in gallons;
- m. Estimated SSO volume that reached surface water, drainage channel, or not recovered from a storm drain.
- n. Estimated SSO amount recovered;
- o. SSO source (manhole, cleanout, etc.);
- p. SSO cause (mainline blockage, roots, etc.);
- q. Time of SSO notification or discovery;
- r. Estimated operator arrival time;
- s. SSO destination;
- t. Estimated SSO end time; and
- u. SSO Certification. Upon SSO Certification, the SSO Database will issue a Final SSO Identification (ID) Number.
- v. Response and corrective action taken;
- w. If samples were taken, identify which regulatory agencies received sample results (if applicable). If no samples were taken, NA must be selected.
- x. Parameters that samples were analyzed for (if applicable);

YOSEMITE NATIONAL PARK UTILITIES BRANCH

SEWER SYSTEM MANAGEMENT PLAN

EL PORTAL

SANITARY SEWER SYSTEM (CS 5SSO10735)

- y. Identification of whether or not health warnings were posted;
 - z. Beaches impacted (if applicable). If no beach was impacted, NA must be selected;
 - aa. Whether or not there is an ongoing investigation;
 - bb. Steps taken or planned to reduce, eliminate, and prevent reoccurrence of the overflow and a schedule of major milestones for those steps;
4. 15-Day Reporting Requirement
A final certified report for the Category 1 SSO or spill must be completed through the Online SSO System within 15 calendar days of the conclusion of the SSO response and remediation.
5. 30-Day Reporting Requirement
All Category 2 SSOs as defined in Section 6.1 must be reported to the Online SSO System within 30 days after the end of the calendar month in which the SSO occurred (e.g. all SSOs occurring in the month of January must be reported/entered into the database by March 1st.) The content of the certified Category 2 SSO or spill report will include:
- a. Location of SSO by entering GPS coordinates;
 - b. Identify the region in which the SSO occurred (El Portal is served by the Central Valley Regional Water Quality Control Board) ;
 - c. County where SSO occurred; (El Portal is in Mariposa County)
 - d. Whether or not the SSO entered a drainage channel and/or surface water;
 - e. Whether or not the SSO was discharged to a storm drain pipe that was not fully captured and returned to the sanitary sewer system;
 - f. Estimated SSO volume in gallons;
 - g. SSO source (manhole, cleanout, etc.);
 - h. SSO cause (mainline blockage, roots, etc.);
 - i. Time of SSO notification or discovery;
 - j. Estimated operator arrival time;
 - k. SSO destination;
 - l. Estimated SSO end time; and
 - m. SSO Certification. Upon SSO Certification, the SSO database will issue a final SSO Identification (ID) Number.

YOSEMITE NATIONAL PARK UTILITIES BRANCH

SEWER SYSTEM MANAGEMENT PLAN

EL PORTAL

SANITARY SEWER SYSTEM (CS 5SSO10735)

6. 30-Day Reporting Requirement
If there are no SSOs during the calendar month, the Park Superintendent will provide, within 30 days after the end of each calendar month, a statement through the Online SSO Database certifying that there were no SSOs for the designated month.
7. Yearly Reporting Requirement
The “Collection System Questionnaire” must be updated by the Utilities Branch at least every 12 months.

Updates to any previous spill report can be submitted at any time but the updated report must be certified by the Park Superintendent.

6.5 RECORD KEEPING AND OTHER PUBLIC NOTIFICATION

Individual SSO records shall be maintained by the Utilities Branch for a minimum of five years from the date of the SSO. This period may be extended when requested by the CVRWQ Board. All records shall be made available for review upon State or Regional Water Board staff’s request. All monitoring instruments and devices that are used to fulfill the prescribed monitoring and reporting program shall be properly maintained and calibrated as necessary to ensure their continued accuracy.

The Utilities Branch shall retain records of all SSOs, such as, but not limited to and when applicable:

- a. Record of Certified report, as submitted to the online SSO database;
- b. All original recordings for continuous monitoring instrumentation;
- c. Service call records and complaint logs of calls received;
- d. SSO calls;
- e. SSO records;
- f. Steps that have been and will be taken to prevent the SSO from recurring and a schedule to implement those steps.
- g. Work orders, work completed, and any other maintenance records from the previous 5 years which are associated with responses and investigations of system problems related to SSOs;
- h. A list and description of complaints from customers or others from the previous 5 years; and

YOSEMITE NATIONAL PARK UTILITIES BRANCH

SEWER SYSTEM MANAGEMENT PLAN

EL PORTAL

SANITARY SEWER SYSTEM (CS 5SSO10735)

- i. Documentation of performance and implementation measures for the previous 5 years.

If water quality samples are required by an environmental or health regulatory agency or State law, or if voluntary monitoring is conducted by the YNP, as a result of any SSO, records of monitoring information shall include

- a. The date, exact place, and time of sampling or measurements;
- b. The individual(s) who performed the sampling or measurements;
- c. The date(s) analyses were performed;
- d. The individual(s) who performed the analyses;
- e. The analytical technique or method used; and,
- f. The results of such analyses.

Public notification may be required if barricades, signage, or other traffic/pedestrian control measures are not adequate to protect public safety from exposure to a major SSO. The Park Superintendent and Utilities Branch shall jointly determine if public notification is required.

6.6 FAILURE ANALYSIS INVESTIGATION

The objective of the failure analysis investigation is to determine the “root cause” of the SSO and to identify corrective action(s) needed that will reduce or eliminate potential for the SSO to recur. The investigation should include reviewing all relevant data to determine appropriate corrective action(s) for the sewer segment. This investigation should be conducted by the USRO supervisor and assisted by the USRO staff. The investigation may include a combination of the following:

- Review and complete/correct the spill report presented in Exhibit 6.1
- Review past maintenance records;
- Review original construction plans and regulatory reports;
- Review available photographs and logs of the SSO,
- Perform a CCTV inspection to determine the condition of the sewer segment,
- Interview staff who responded to the spill, as well as local residents having sewer connections.

YOSEMITE NATIONAL PARK UTILITIES BRANCH

SEWER SYSTEM MANAGEMENT PLAN

EL PORTAL

SANITARY SEWER SYSTEM (CS 5SSO10735)

The product of the failure analysis investigation should be the determination of the root cause and the identification of corrective actions necessary to prevent the reoccurrence of an SSO. Corrective actions may include one or a combination of sewer cleaning, sewer repair, sewer rehabilitation, or sewer replacement.

6.7 BASIC EMERGENCY RESPONSE EQUIPMENT AND SUPPLIES

The following is a list of equipment and supplies that should be readily available for all USRO staff responding to a spill.

- Copy of the Overflow Emergency Response Plan with recording instruments and digital or disposable camera to document the spill.
- Service Truck with hand tools such as shovel, wrenches, caution tape, etc. and provisions for disinfection such as water, soaps, chlorine, towels, etc.
- Personal protective equipment to include gloves, coveralls, footwear, eyewear, and headgear if required.
- Sampling equipment to include EPA cleaned and appropriately preserved sampling containers, labels, chain of custody, gloves, sample collection bucket for compositing samples, sample dipper with extension, etc.
- Materials staged at the local maintenance yards should include sandbags, barricades and cones, rakes, plastic sheeting, drop-inlet mats, oil absorbent pads.

The USRO supervisor should have the following minimum equipment and materials staged or contracts in-place for immediate deployment upon request:

- Sewage hydro or vacuum truck
- Portable pumps and flusher truck
- Portable generator
- Backhoe or excavator
- Dump truck
- Source of backfill for earthen berm construction
- Hand held GPS unit

YOSEMITE NATIONAL PARK UTILITIES BRANCH

SEWER SYSTEM MANAGEMENT PLAN

EL PORTAL

SANITARY SEWER SYSTEM (CS 5SSO10735)

6.8 SSO RESPONSE TRAINING

All NPS personnel who may have a role in responding to, reporting, and/or mitigating a wastewater collection system overflow should receive training on the contents of this OERP. All new employees should receive training before they are placed in a position where they may have to respond and current employees should receive annual refresher training on this plan and the procedures to be followed. Training should include:

- First aid safety,
- Use of personal protective equipment and respirators,
- Fall protection,
- Confined space entry,
- Lockout/tagout procedures,
- Chemical handling,
- Accident investigation,
- Equipment safety, and
- Other training as determined by the USRO supervisor.

Additionally, all contractor personnel working who may have a role in responding to, reporting to the NPS, and/or mitigating a wastewater collection system overflow such as contractors performing sewer repairs or replacement should receive training on the contents of the OERP.

Records should be kept by the USRO supervisor of all training that is provided in support of this plan. The records for all training courses or emergency response training event should include date, time, place, content, name of trainer(s), and names of attendees.

The Utilities Branch Facility Manager or designee should conduct annual training drills or 'table-top' exercises if no SSO occurred during the previous year to ensure that USRO staff and/or contractor employees are up to date on the procedures, the equipment is in working order, and the required materials are readily available. The training drills should cover scenarios typically observed during sewer related emergencies (e.g. mainline blockage, mainline failure, force main failure, lift station failure, and lateral blockage). The results along with observations made during the drills

YOSEMITE NATIONAL PARK UTILITIES BRANCH

SEWER SYSTEM MANAGEMENT PLAN EL PORTAL SANITARY SEWER SYSTEM (CS 5SSO10735)

should be recorded and action items should be tracked by the USRO supervisor to completion to ensure USRO staff understands the content of the OERP.



Exhibit 6.1 Yosemite Utilities Branch SSO Report

1. Estimated spill volume? _____ gallons

2. Estimated volume of spill recovered? _____ gallons
Estimated volume of spill not recovered? _____ gallons
This is a Category 1 spill if ≥ 1000 gallon of the spill is not recovered,

3. Did the spill discharge to a drainage channel and/or surface water? Yes No
if yes, this is a Category 1 spill.

4. Did the spill discharge to a storm drainpipe that was not fully captured and returned to the sanitary sewer system? Yes No *if yes, this is a Category 1 spill.*

5. Spill location name: _____

6. Latitude of spill location: _____ deg: _____ min. _____ sec. or _____ decimal degrees.

7. Longitude of spill location: _____ deg: _____ min. _____ sec. or _____ decimal degrees.

8. Spill Location: street number, street name, cross street, street type, street direction, suite or apt number:

9. Spill Location: County, city, state, zip: _____

10. Spill Location: Other description: _____

11. Contact Central Valley Regional Water Quality Control Board: Fresno office

12. Spill appearance point or source of spill: (check all that apply)

- Building or Structure Force Main or Pressure Sewer Gravity Sewer
Manhole Other Sewer Structure Pump Station
Other

13. Spill appearance point explanation: (if above is "Other")

14. Final spill destination:

- Storm Drain Street/Curb & Gutter Surface Water
Unpaved Surface Beach Building
Other

15. Explanation of final destination: (if above is "Other")

16. Estimated volume of spill that reached surface water, drainage channel, or gallons not recovered:

_____ gallons. *This is a Category 1 spill if any volume of the spill reaches surface water or drainage channel or if >1000 gallon of the spill is not recovered.*

17. Estimated current spill rate (if applicable): Gallons per minute: _____
18. Estimated spill start date/time: _____
19. Date and time sanitary sewer system agency was notified or, or discovered spill: _____
20. Estimated Operators arrival date/time: _____
21. Estimated spill end date/time: _____
22. Spill cause:
- | | | |
|---|---|--|
| Debris-General <input type="checkbox"/> | Debris-Rags <input type="checkbox"/> | Flow Exceeded Capacity <input type="checkbox"/> |
| Grease Deposit (FOG) <input type="checkbox"/> | Operator Error <input type="checkbox"/> | Pipe Structural Problem/Failure <input type="checkbox"/> |
| Pump Station Failure <input type="checkbox"/> | Rood Intrusion <input type="checkbox"/> | Rainfall Exceeded Design <input type="checkbox"/> |
| Vandalism <input type="checkbox"/> | Other <input type="checkbox"/> | |
23. Spill cause explanation: (if above is "Other")
- _____
- _____
- _____
- _____
- _____
24. If spill caused by wet weather, choose size of storm (year):
- 1 2 5 10 50 100
25. Diameter of sewer pipe at the point of blockage or spill cause (if applicable): _____ inches
26. Material of sewer pipe at the point of blockage or spill cause (if applicable): _____
27. Estimated age of sewer pipe at the point of blockage or spill cause (if applicable): _____

28. Spill response activities (check all that apply):

Cleaned up (mitigated effects of spill)

Contained all or portion of spill

Inspected sewer using CCTV to determine cause

Restored Flow

Returned all or portion of spill to sanitary sewer system

Other

29. Explanation of spill response activities (if above is "Other"):



Category 1 spill only

- 1) Equals or exceeds 1000 gallons; or
- 2) A discharge of sewage to a surface water and/or drainage channel, or
- 3) A discharge of sewage to a storm drain that was not fully captured and returned to the collection system

30. Spill response completion date: _____
31. Health warnings posted? Yes No
32. Name of impacted surface water(s) (if applicable): _____

33. Visual inspection results from impacted receiving waters:

34. Is there an ongoing investigation? Yes No
35. Water quality samples analyzed for: _____

36. Water quality sample results reported to: _____

37. Explanation of water quality sample results: _____

38. Spill corrective action taken (check all that apply):
Added to preventative maintenance program
Adjusted schedule/method of preventative maintenance
Enforcement action against FOG source
Plan rehabilitation or replacement of sewer
Repaired sewer
Other
39. Explanation of spill corrective actions taken (if above is "Other"): _____

40. Office of Emergency Services (OES) Control Number: _____
41. OES Notified; Date/Time: _____
42. County health agency notified? Yes No
43. County health agency notified; Date/Time: _____
44. Central Valley Regional Water Quality Control Board notified; Date/Time: _____
45. Other agency notified: _____

The USRO staff and supervisor are responsible for completing items 1 through 39 and the Utilities Facilities Manager, or designee is responsible for spill notifications per items 40 through 45. But the information collected in items 1 through 39 is required for spill notification.

Draft spill certification is prepared by the Utilities Facilities Manager or designee and submitted to the Park Superintendent or designee for final spill certification and regulatory submittal.

**EXHIBIT 6.2
Dispatch Spill Contact Phone Numbers**

IF SPILL IS MORE THAN 1,000 GAL., CALL CA STATE OFFICE OF EMER. SERVICES AT:

WARNING CENTER (24 HOURS) (800) 852-7550 or
(916) 262-1621
Facsimile (FAX) Number (916) 262-1677

FOR SPILLS TO LAND ONLY

Agency/Company Name	Contact Name	Phone Numbers
Regional Board	Lonnie Wass Aide Ortiz	(559) 445-5116 (559) 445-6083 (559) 445-6190 (W)
Mariposa County Health Department	Dave Conway	(209) 966-2220 (Ofc) (209) 966-5437 (H)
Only one person on list needs to be notified for after hours calls, calls should be made in the order listed	Brian Hodge Dr. Charles Mosher	(209) 742-9725 (P) (209) 742-4937 (H) (209) 742-9725 (P) (209) 742-7433 (H) (209) 742-9952 (P)
Yosemite NPS Dispatch Public Information Office, Public Affairs Specialist	Scott Gediman	(209) 379-1997 (209) 372-0529 (W)
NPS Safety Officer		(209) 379-1079

**FOR SPILLS TO THE MERCED RIVER BETWEEN YOSEMITE VALLEY AND EL PORTAL WWTF,
CALL THE ADDITIONAL NUMBERS BELOW**

List is prioritized by drinking water suppliers in order of distance downstream, then by public access points from upstream to downstream with the facility closest to El Portal WWTF first.

WATER USERS

Agency/Company Name	Contact Name	Phone Numbers
Mariposa PUD	Mark Rowney, Mgr	(209) 966-2515 (D) (209) 742-2800 After hrs. pager
Lake Don Pedro Community Services District	Dan Tyan	(209) 852-2331 (D) (209) 572-8002 (P)
Merced Irrigation District	Bill Latronica	(209) 378-2521 (800) 468-8889 (D) (209) 563-6580 (H) (209) 385-4470 (P)
Lake McClure McSwain Res. Parks Department	James Mills	(209) 378-2520

**EXHIBIT 6.2 (Continued)
Dispatch Spill Contact Phone Numbers**

PUBLIC ACCESS FACILITIES

Agency/Company Name	Contact Name	Phone Numbers
Bagby Ranger	Bret Surdich	(209) 376-4475 (209) 742-9375 (P)
BLM Red Bud Boat Launch		(209) 966-3638
USFS Dry Gulch and Dirt Flat Campground		(209) 966-3638
BLM Ranger (for Briceburg campground)	David Greenwood, Ranger Chuck Brazzel	(209) 379-2667 (April-Labor Day only) (209) 966-3192 (Labor Day through March)
Department of Fish and Game	Frank D. Milazzo, Warden Or Allied Agency	(209) 966-3376 (916) 358-1310 (888) 334-2258

COURTESY CALLS TO OTHER DOWNSTREAM PARTIES

Agency/Company Name	Contact Name	Phone Numbers
Yosemite View Lodge		(209) 379-2681
Indian Flat		(209) 379-2339
Cedar Lodge		(209) 379-2612
Yosemite Redbud Lodge/Savages / Trading Post/Sisochi Gallery		(209) 379-2301
Mariposa County Sheriff		(209) 966-3614

Notification Phone List for Spills in Tuolumne Meadows

IF SPILL IS MORE THAN 1,000 GAL., CALL CAL STATE OFFICE OF EMER. SERVICES AT:

Warning Center (24 hours)		(916) 262-1621
Facsimile (FAX) Number		(916) 262-1677
Agency/Company Name	Contact Name	Phone Numbers
Regional Board	Wendy Wyels Jim Martin	(916) 255-3135 (916) 255-3385
Tuolumne County Health Department		(209) 533-5990
Yosemite NPS Dispatch Public Information Office, Public Affairs Specialist		(209) 372-0248

EXHIBIT 6.2 (Continued)
Dispatch Spill Contact Phone Numbers

FOR SPILLS TO THE TUOLUMNE RIVER, CALL THE ADDITIONAL NUMBERS BELOW

List is prioritized by drinking water suppliers in order of distance downstream,
then by public access points from upstream to downstream with the facility closest to
the Tuolumne Meadows WWTF first.

WATER USERS

Agency/Company Name	Contact Name	Phone Numbers
NPS/BCU Glen Aulin HSC water system	Korwin Kirk	(209) 379-1250
City and County of San Francisco	Mike Williams	(209) 989-2084
	Moccasin Power Plant (24 hours)	(209) 989-2099

PUBLIC ACCESS FACILITIES

Agency/Company Name	Contact Name	Phone Numbers
Glen Aulin High Sierra Camp		Radio
Hetch Hetchy Water & Power Water Shed Keeper 9600 Hetch Hetchy Road		(209) 379-2697 (209) 379-2695 (209) 379-2622
Hetch Hetchy Entrance Station		(209) 379-1922
Mather District Rangers		(209) 379-1896

YOSEMITE NATIONAL PARK UTILITIES BRANCH

SEWER SYSTEM MANAGEMENT PLAN EL PORTAL SANITARY SEWER SYSTEM (CS 5SSO10735)

This page left intentionally blank.

YOSEMITE NATIONAL PARK UTILITIES BRANCH

SEWER SYSTEM MANAGEMENT PLAN EL PORTAL SANITARY SEWER SYSTEM (CS 5SSO10735)

7.0 FOG CONTROL PROGRAM

YOSEMITE NATIONAL PARK UTILITIES BRANCH

SEWER SYSTEM MANAGEMENT PLAN EL PORTAL SANITARY SEWER SYSTEM (CS 5SSO10735)

7.1 REGULATORY REQUIREMENTS FOR THE FOG CONTROL PROGRAM ELEMENT

This Fats Oils and Grease (FOG) Control Program describes the National Park Service (NPS) actions for Yosemite National Park (YNP) to assess and evaluate its sewer lines for the purpose of implementing a FOG control program as needed for compliance with the condition of the California State Water Resources Control Board (SWRCB) Order No. 2006-0003, Statewide General Discharge Requirements for Sanitary Sewer Systems. Board Order No. 2006-0003 requires sanitary sewer systems to develop and implement sewer system management plans (SSMPs) for preventative maintenance requirements for controlling FOG. Furthermore, Board Order No. 2006-0003 details the content requirements for the FOG control program that should include:

YOSEMITE NATIONAL PARK UTILITIES BRANCH

SEWER SYSTEM MANAGEMENT PLAN EL PORTAL SANITARY SEWER SYSTEM (CS 5SSO10735)

7.2 NATURE AND EXTENT OF FOG PROBLEM

The El Portal sewer system is comprised of five distinct sewer service areas:

1. Maintenance Complex,
2. Rancheria Flat,
3. The Trailer Park Court,
4. Old El Portal, and
5. Yosemite View Lodge.

These sewer systems discharge into the 16 inch sewer mainline that runs from Yosemite Valley to the El Portal wastewater treatment plant. These sewer systems are shown in Figures 4.2 to 4.9.

There have been 6 SSO's in the El Portal sewer collection system from 2008 to 2012. Table 7-1 presents the causes of those SSO's.

**TABLE 7.1
Analysis of SSO Data for El Portal (2008 to 2013)**

Performance Indicator			
Primary Cause of SSO's	Total Volume of SSOs (gallons)	Number of SSOs	0.29 SSO/mile/year
<u>Roots (2-Old EL Portal & 1-Rancheria Flats)</u>	1200	3	50%
Grease (Old El Portal)	30	1	16.66%
Debris	-	0	0%
Pipe Failures	-	0	0%
Lift Station Failure (Trailer Park Court)	20	1	16.66%
Line Blockage	75	1	16.66%
Other	-	0	0%

YOSEMITE NATIONAL PARK UTILITIES BRANCH

SEWER SYSTEM MANAGEMENT PLAN EL PORTAL SANITARY SEWER SYSTEM (CS 5SSO10735)

El Portal has reported one FOG-related SSO event that was located in the Old El Portal area, illustrated in Figures 4.6 and 4.7. The spill occurred on October 19, 2010 involving pipe segment manhole EP30 and EP3001. The associated pipeline is located downstream of the Carol Clark Community Hall. This segment of the sewer collection system receives sewer from approximately seven residential buildings upstream and the Carol Clark Community Hall. Therefore, the sewer lines serving the residential areas should be included as having potential FOG concerns in addition to the community hall.

In addition to the one FOG related SSO, the El Portal sewer collection system has multiple sewer pipeline segments that indicate an accumulation of FOG, based on the 2009 CCTV inspection. The Trailer Park Court has service connections for recreational vehicles that are typically used for seasonal workers that drain waste containing FOG into the system.

There are relatively few commercial FOG sources that discharge into the El Portal wastewater collection system given the overall size of the collection system. However, there are some areas in El Portal that have commercial kitchens or food preparation facilities that include a school in Rancheria Flats, community hall and delicatessen market in Old El Portal and restaurants in Yosemite View Lodge Resort.

7.3 CLEANING SCHEDULE FOR IDENTIFIED FOG PRONE SEWER SEGMENTS

The NPS has a cleaning program where pipe segments are cleaned on a regular basis. The pipelines that represent areas of concern as described in Section 7.2 have been scheduled for more frequent sewer cleaning or jetting to prevent FOG buildup that may lead to an SSO. These areas scheduled for more frequent maintenance are shown in Section 4, Table 4.2.

The NPS plans to continue with the current cleaning program, gather cleaning data over the next two years. This data will identify specific pipes having grease issues and will be utilized to focus hotspot cleaning on pipes with known grease issues.

YOSEMITE NATIONAL PARK UTILITIES BRANCH

SEWER SYSTEM MANAGEMENT PLAN

EL PORTAL

SANITARY SEWER SYSTEM (CS 5SSO10735)

7.4 PUBLIC OUTREACH PROGRAM

The public outreach program for the El Portal sewer collection system should be focused primarily upon businesses privately owned and operated to also include any NPS concessionaires and vendors. Educational information on minimizing FOG, proper disposal of FOG and other SSO prevention measures, including installation of backflow protection valves, service lateral maintenance, etc. should be disseminated through publication of an Annual Report, brochures, articles in NPS newsletters, the Park's webpage and individual notices to concessionaires and vendors. The USRO staff should also interact with businesses privately owned and operated including concessionaires and vendors during contractual negotiations regarding contractual agreements requiring the implementation of FOG prevention programs. These methods have proven to be very effective in relaying information on proper disposal of FOG and SSO prevention methods to residents.

7.5 FOG REMOVAL DISPOSAL FACILITIES

All grease removal device waste shall be disposed of offsite at an approved receiving facility and not at the El Portal wastewater facility. A list of FOG disposal sites and liquid waste haulers is given in Table 7-2. The NPS will update the list annually. Currently, El Portal's system has a need for this information to be distributed by the NPS to the residents, businesses privately owned and operated, concessionaires, vendors and other facilities with kitchens. The information will be disseminated through publication of an Annual Report, the Park's web page, brochures, and articles in NPS newsletters. The number and close proximity of the disposal sites is adequate to handle liquid wastes being removed from current and future grease removal equipment within El Portal sewer collection system.

YOSEMITE NATIONAL PARK UTILITIES BRANCH

SEWER SYSTEM MANAGEMENT PLAN EL PORTAL SANITARY SEWER SYSTEM (CS 5SSO10735)

**TABLE 7.2
Grease Haulers and FOG Disposal Facilities**

Mariposa County – Grease Rendering / Drop Off Points for the El Portal Area		
All Valley Environmental, Inc.	523 N Brawley Ave., Fresno, CA 93706	(559) 498-8378
Eldorado Septic Services, Inc.	18701 Tiffany #2f Twain Harte, CA	(209) 586-1623
Modesto Tallow / Florin Tallow Co.		(209) 522-7224 (800) 564-7204
One More Time		(800) 624-5504
Reference: Grease Haulers and FOG Disposal Facilities serving the NPS Yosemite area as of March 2013 are shown in the following lists. (Source: http://www.calfog.org/Hauler.html)		

Currently, solidified fats found in the collection system during scheduled cleaning operations are trapped, collected and taken to FOG disposal facilities. Other debris collected from the system is taken to El Portal wastewater facility. FOG in liquid form should be flushed downstream by hydro jetting to lift stations for treatment and disposal. The NPS will continue with the current program and will evaluate the effectiveness of the program.

YOSEMITE NATIONAL PARK UTILITIES BRANCH

SEWER SYSTEM MANAGEMENT PLAN

EL PORTAL

SANITARY SEWER SYSTEM (CS 5SSO10735)

7.6 FOG SOURCE CONTROL MEASURES

The NPS's legal authority to enforce the requirements stipulated in this Section is discussed in detail in Section 3 whereby the authority to form contractual agreements with concessionaires, vendors and other commercial food establishments is also established. A summary of the current system users and associated FOG Control activities are listed in Table 7-3.

TABLE 7.3
Summary of FOG Control Program Activities

FOCUS	ACTIVITY	STATUS
Commercial Food Sources	Identify FOG disposal sites and distribute information to liquid waste haulers.	NPS to provide with contract agreement.
	Encourage/enforce the use of BMPs in commercial kitchens.	NPS will encourage/enforce through contract agreement use of BMPs during inspections.
High Density and Low Density Residential Sources	Repair/replace problem sewers identified during CCTV inspection program.	Ongoing
	Prepare and publish outreach materials.	NPS to prepare materials for Annual Report, brochures, articles in NPS newsletters, the Park's web page, and individual notices distributed to property owners.
Sewer System Performance	Gather information for next SSMP update.	Ongoing

YOSEMITE NATIONAL PARK UTILITIES BRANCH

SEWER SYSTEM MANAGEMENT PLAN

EL PORTAL

SANITARY SEWER SYSTEM (CS 5SSO10735)

The USRO supervisor is authorized to enforce agreements and inspect waste facilities that discharge into the El Portal sewer collection system. The legal authority to prohibit discharges of FOG into the sewer system is given in Section 3 of this SSMP. Domestic waste containing FOG can lead to SSOs, which are public nuisances, and California Health and Safety Code Division 5, Part 3, Chapter 6, Article 2 can also be used to impose appropriate domestic sewage discharge requirements. Requirements for grease interceptors at food service establishments to prevent the discharge of grease into the sewer system and educating the public on proper disposal methods for FOG are discussed below.

7.6.1 PROHIBITED DISCHARGES

The following items contribute to the accumulation of FOG within sewer collection systems and thereby can create the potential of SSOs. The following items are prohibited from being discharged into the El Portal sewer collection system.

Additives

The use of additives shall not be considered an alternative to mechanical devices for the removal of grease. Additives are prohibited.

FOG and Solid Material

The discharge of any waste or wastewater from a grease removal device such as grease interceptors or grease traps is prohibited. All waste and wastewater removed from a grease removal device shall be transported to a disposal facility in accordance with the operation and maintenance requirements of the device.

Food Grinders

Food grinders that discharge waste to the sewer collection system are prohibited.

High Temperature Discharges

Discharge of wastewater with temperature in excess of 140 degree F into any grease removal device is prohibited. The discharge of high temperature wastewater creates an increase potential of the device failing by liquefying the contained grease.

YOSEMITE NATIONAL PARK UTILITIES BRANCH

SEWER SYSTEM MANAGEMENT PLAN

EL PORTAL

SANITARY SEWER SYSTEM (CS 5SSO10735)

Sanitary Waste

All wastewater from toilets, urinals, wash basins and other fixtures containing fecal materials shall be prohibited from discharging into a grease removal device.

Waste Cooking Oil

The discharge of waste cooking oil into the FSE sanitary sewer service connection is prohibited. All waste cooking oils shall be collected, stored and transported to a disposal facility in accordance with the operation and maintenance requirements of the establishment.

7.6.2 REQUIREMENTS TO INSTALL GREASE REMOVAL DEVICES

The best means available for controlling FOG is the use of grease removal devices such as grease interceptors or grease traps. Establishments that produce and discharge FOG containing wastewater shall be required to install adequately –sized FOG removing devices on all discharge lines that connect to drains for fixtures, equipment, clean-up, etc. that have the potential to discharge FOG containing wastewater. Grease removal devices shall be designed and installed in accordance to Section 7.7.

The businesses privately owned and operated including NPS's concessionaire and vendor contract agreement shall be required to take measures to reduce loadings and prevent SSO's through installation of grease removal devices. The recommended conditions for future contractual agreements are included in Appendix A – FOG Control Supplement.

7.6.3 FOG PREVENTATIVE MAINTENANCE

The NPS currently employs preventive maintenance as the primary method to address FOG issues in the system. Users of the sewer collection system shall only discharge wastewater acceptable to the FOG program. The maintenance of the integral components of the users' systems and device(s) for the removal of FOG constituents must be maintained on a regular and proactive basis. Record keeping of maintenance activities shall be kept in accordance to Section 7.7.

YOSEMITE NATIONAL PARK UTILITIES BRANCH

SEWER SYSTEM MANAGEMENT PLAN

EL PORTAL

SANITARY SEWER SYSTEM (CS 5SSO10735)

As a minimum, preventative maintenance will include the following:

1. Grease removal devices shall be maintained in operating conditions by regular and scheduled removal of all contents of the device.
2. Grease removal device maintenance frequency shall be determined by one of the following methods:
 - a. Grease interceptors shall be pumped and cleaned quarterly.
 - b. Grease traps shall be cleaned regularly, not to exceed 90 days in frequency.
 - c. Cleaning of devices shall remove all waste and any FOG waste. Accumulated or caked on FOG and other debris shall be removed. Removable baffles shall be taken out during cleaning, cleaned and replaced.
 - d. The establishment may submit a request to decrease the maintenance frequency. The request shall document the actual accumulation of FOG based on a minimum of two years of maintenance history.
 - e. If the grease removal device, at any time, contains sufficient quantity of FOG and other solids that prevent the device from adequately treating the waste of FOG prior to discharge, the grease removal device shall immediately be serviced. NPS may require an increase in the maintenance frequency based on the incident.

The businesses privately owned and operated including NPS's concessionaire and vendor contract agreement shall be required to maintain grease removal devices for loading reduction and SSO prevention. The recommended conditions for future contractual agreements are included in Appendix A – FOG Control Supplement.

YOSEMITE NATIONAL PARK UTILITIES BRANCH

SEWER SYSTEM MANAGEMENT PLAN

EL PORTAL

SANITARY SEWER SYSTEM (CS 5SSO10735)

7.7 DESIGN, MAINTENANCE AND RECORD KEEPING

Pretreatment devices are required for FOG generating facilities, including restaurants and other commercial food establishments. They are required to be designed per the latest approved edition of the California Uniform Plumbing Code (UPC).

7.7.1 DESIGN STANDARDS FOR GREASE REMOVAL DEVICES

Design and sizing of grease interceptors should be determined through the use of the latest approved edition of the California Uniform Plumbing Code. The device shall at a minimum have two compartments with fittings designed for grease retention. The device shall be installed in a location that allows for clear access for inspection, cleaning and removal of accumulated grease.

Businesses privately owned and operated including concessionaires, vendors, and other establishments that discharge FOG containing wastewater shall submit an inventory listing the size and condition of all grease interceptors and inlet piping size at El Portal. Pump out and inspect internal condition. Upgrade and/or replace as necessary to bring facility into conformance with the sizing requirements of the UPC. Prepare record drawings upon NPS Engineer's direction.

The recommended conditions for future contractual agreements are included in Appendix A – FOG Control Supplement.

7.7.2 MAINTENANCE REQUIREMENTS

Communication between all parties within YNP, businesses privately owned and operated and concessionaire management and individual facility kitchen managers, and appropriate staff, as relating to grease management need to be ongoing due to special conditions, including seasonal employee turnover rate. Copies of all grease management plans, policies and procedures will be posted or otherwise made available at each site subject to the requirements of the GMP's. Updated copies will need to be redistributed as updates and revisions occur.

Written verification will be available identifying that specific procedures were performed and followed correctly for the items given in Table 7.4.

YOSEMITE NATIONAL PARK UTILITIES BRANCH

SEWER SYSTEM MANAGEMENT PLAN EL PORTAL SANITARY SEWER SYSTEM (CS 5SSO10735)

TABLE 7.4
Written Policy for Procedures – Performed and Followed

Written Policy for Procedures – Performed and Followed		
Task	Frequency	Records
Grease inspection	weekly	Log
Trap / interceptor cleaning logs	weekly	Log
Inspections of Facility Operations	weekly	Log
Spill Procedures	Upon Hire, monthly	Log
Pretreatment Procedures	Upon Hire, Bi-weekly	Log training sessions and testing
Employee Training	Upon hire, monthly, annually	Log
Sewer Line Cleaning	YNP to schedule, and as needed	Log
Sampling	annually	Log
Audit and Certification	annually	Log
Corrective Actions	To follow inspections of facility ASAP	Log results

YNP will through contractual agreements have businesses privately owned and operated including concessionaires, vendors, and other establishments that discharge FOG containing wastewater establish a training program for all kitchen staff, managers, maintenance personnel and any commercial removal companies in order to ensure that requirements of the GMP's, policies and procedures are clear to all parties involved. The training needs to include the requirements for written documentation relating to all required inspections, maintenance, annual audits/certification and training.

The recommended conditions for future contractual agreements are included in Appendix A – FOG Control Supplement.

YOSEMITE NATIONAL PARK UTILITIES BRANCH

SEWER SYSTEM MANAGEMENT PLAN

EL PORTAL

SANITARY SEWER SYSTEM (CS 5SSO10735)

7.7.3 RECORD KEEPING REQUIREMENTS

All parties operating and maintaining FOG required devices shall be required to keep all manifests, receipts, and invoicing of all cleaning, maintenance, grease removal of/from the grease removal device, disposal carrier and disposal site location for a minimum of five years as cited under legal authority documents referenced in Section 3.

The recommended conditions for future contractual agreements are included in Appendix A – FOG Control Supplement.

7.7.4 BEST MANAGEMENT PRACTICES REQUIREMENTS

Best management practices (BMPs) are activities, practices, facilities, and/or procedures that when implemented to the maximum extent practicable will prevent or reduce pollutants in discharges. Under the agreement, commercial food preparation facilities will be responsible for implementation of all policies, procedures, BMP's and all other requirements of the GMP's. Some examples of BMPs are: scraping and dry wiping dishes and cooking utensils prior to washing, general good housekeeping, and proper waste handling, and disposal, spill procedures, sewer line cleaning within a structure. The businesses privately owned and operated including concessionaires, vendors, and other establishments that discharge FOG containing wastewater will incorporate training that includes spill awareness, response, and documentation/recordkeeping, specific posting of signs and kitchen pretreatment procedures at commercial food preparation facilities. Annual sampling, record keeping and reporting will be performed through submittal of paperwork associated with grease management to YNP as it becomes available or upon YNP request. This paperwork will provide a tracking mechanism and will be appropriate for evaluating commercial establishments that discharge FOG containing wastewater individual kitchen manager responsibilities/accountabilities and performance and evaluations of any necessary adjustments to the overall grease management program. This will provide additional support to the YNP Sanitary Sewer Master Plan for the sanitary sewer collection system. Including maintenance of complete inspection/cleaning records with data that is uniformly reported, irrespective of the individual completing them.

YOSEMITE NATIONAL PARK UTILITIES BRANCH

SEWER SYSTEM MANAGEMENT PLAN EL PORTAL SANITARY SEWER SYSTEM (CS 5SSO10735)

Commercial establishments that discharge FOG containing wastewater shall follow current and future inspection and cleaning schedules to be adjusted annually based on the end of year audits and the seasonal nature of the facility.

The recommended conditions for future contractual agreements are included in Appendix A – FOG Control Supplement.

YOSEMITE NATIONAL PARK UTILITIES BRANCH

SEWER SYSTEM MANAGEMENT PLAN EL PORTAL SANITARY SEWER SYSTEM (CS 5SSO10735)

8.0 SYSTEM EVALUATION AND CAPACITY ASSURANCE PLAN

YOSEMITE NATIONAL PARK UTILITIES BRANCH

SEWER SYSTEM MANAGEMENT PLAN

EL PORTAL

SANITARY SEWER SYSTEM (CS 5SSO10735)

8.1 CAPACITY ASSURANCE PROGRAM REQUIREMENTS

This System Evaluation and Capacity Assurance (SECA) Plan describes the National Park Service (NPS) actions for Yosemite National Park (YNP) to assess and evaluate sewer hydraulic flows for the purpose of determining sewer capacity which is an essential element in the management of a sewer collection system and a compliance condition with the California State Water Resources Control Board (SWRCB) Order No. 2006-0003, Statewide General Discharge Requirements for Sanitary Sewer Systems. Board Order No. 2006-0003 requires sanitary sewer systems to develop and implement sewer system management plans (SSMPs) for managing, operating, and maintaining sewer systems for the prevention of sewer system overflows (SSOs). Furthermore, Board Order No. 2006-0003 details the content requirements for SECA Plans and should include:

1. Evaluation: Actions needed to evaluate those portions of the sanitary sewer that are experiencing or contributing to SSO discharges caused by hydraulic deficiency. The evaluation must provide estimates of peak flows associated with conditions similar to those causing SSOs, estimates of the capacity of key system components, hydraulic deficiencies, and the major sources that contribute to the peak flows associated with SSOs.
2. Design Criteria: Establish appropriate sewer system design criteria.
3. Capacity Enhancement Measures: Develop capacity enhancement measures with a short- and long-term capital improvement plan (CIP) that addresses and identifies hydraulic deficiencies, including prioritization, alternative analysis, implementation schedule, and budget.
4. Schedule: Develop a schedule of completion dates for capacity enhancement measures employed.

YOSEMITE NATIONAL PARK UTILITIES BRANCH

SEWER SYSTEM MANAGEMENT PLAN

EL PORTAL

SANITARY SEWER SYSTEM (CS 5SSO10735)

The evaluation of the system's hydraulic capacity includes:

1. Estimation of the capacity of the key sewer system components
2. Identification of potential hydraulic deficiencies with the sewer system to include the limiting capacity of sewer system components
3. Identification of the major sources that contribute to peak flows that result in sewer system overflows (SSOs)
4. Documentation of the system plan and pipe details through total station survey methods

Therefore, knowledge of system design and operational deficiencies will lead to the development and implementation of sewer enhancement projects that will help optimize the operational and maintenance program serving the sewer collection system. The sewer enhancement projects will be further divided into short- and long-term capital improvements to be reported in a capital improvement plan (CIP) included in Section 4.4 that describes sewer rehabilitation and repairs. The CIP will present sewer system improvements in a systematic prioritized tabular format with a system improvement schedule and will identify budgetary requirements.

8.2 CAPACITY EVALUATION

8.2.1 GENERAL

The sanitary sewer collection system that serves the El Portal facility is described in detail in Section 4 of this SSMP. The service area for the collection system is comprised of eight basins. A basin boundary is typically defined as the area of sewage that is collected by gravity alone. It may also receive sewerage flow from another sub-basin. Figure 8.1, shows the extent of the basins. Basin No. 1 collects sewer flows from the Maintenance area. Rancheria Flats receives flow from basin 2, basin 3 and basin 4. The Trailer Park receives flow from basin 5. Old El Portal receives flow from basin 6 and basin 7. Yosemite View Lodge receives flow from basin 8. Sewerage flows via gravity and lift stations to a waste water treatment plant for treatment and subsequent permitted indirect and direct discharge to the Merced River.

The assessment of the collection system for portions that are experiencing or contributing to an SSO discharge(s) caused by hydraulic deficiencies require a logical systematic approach that records, tracks, and trends the system's physical conditions,

YOSEMITE NATIONAL PARK UTILITIES BRANCH

SEWER SYSTEM MANAGEMENT PLAN

EL PORTAL

SANITARY SEWER SYSTEM (CS 5SSO10735)

through observations, and measurement of sewer flows. A preliminary estimate of the hydraulic capacity of the key sanitary sewer system elements will be based on the type and number of system users, operational experience of the YOSE Staff, documented SSO's, and other circumstantial documentation.

YNP will determine the hydraulic capacity of the key sanitary sewer system elements within these collection basins by determining the theoretical sewer flows based on the number and types of users and by measuring the actual sewer flow in the system. YNP will compare the calculated flow to the actual measured flow to determine whether there are hydraulic capacity constraints within the collection system that may cause or contribute to an SSO discharge. Follow-up sewer flow assessments should only be required if additional flow data is needed for sewer enhancement project design, if subsequent sewer enhancement projects fail to resolve hydraulic limiting conditions, or if additional capacity is desired for property development or change in sewer users.

Although there has been limited documentation associating sewer capacity and SSOs in the developed area of El Portal, this plan discusses the procedures necessary to assess sewer pipe capacity which is expected to minimize or eliminate the potential for SSOs within the developed area of El Portal caused by hydraulic constraints.

7/20/12 10:14 SETH R18 G:\CLIENTS\NPS\10-0380C\YOSE\NPS\DRAWINGS\CIVIL\FB_1_SITE_EL_PO.DWG XREFS: G:\CLIENTS\NPS\10-0380C\YOSE\NPS\DRAWINGS\BASES\ELPORTAL.DWG; G:\CLIENTS\NPS\10-0380C\YOSE\NPS\DRAWINGS\BASES\EP-UTILS.DWG;

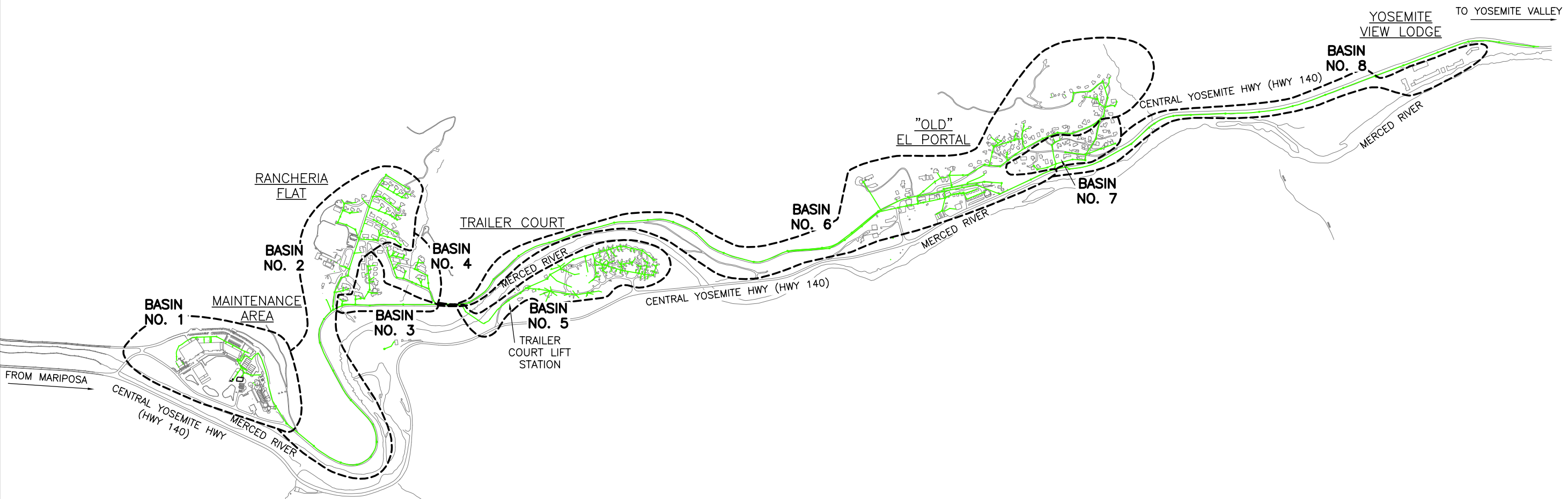

LEGEND:

- SEWER LINE
- SEWER MANHOLE
- - - - - BASIN BOUNDARY

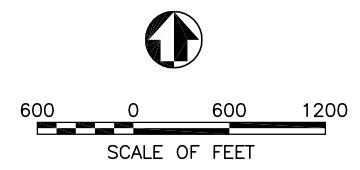

FIGURE 8.1 – SEWER BASIN SITE MAP

SANITARY SEWER MANAGEMENT PLAN

EL PORTAL
YOSEMITE NATIONAL PARK

DATE: 7/2012	S. MCGEEHEE
-----------------	-------------

YOSEMITE NATIONAL PARK UTILITIES BRANCH

SEWER SYSTEM MANAGEMENT PLAN EL PORTAL SANITARY SEWER SYSTEM (CS 5SSO10735)

8.2.2 THEORETICAL SEWER FLOW MODEL

The theoretical sewer flow of the collection system can be modeled through a spreadsheet calculation analysis that incorporates design criteria for the various uses of the service connections. The design criteria for estimating sewer flows as presented in Table 8.1 are taken from Kennedy/Jenks Consultants – Volumes 1 and 2 El Portal Sanitary Sewer System Capital Improvement Plan, Yosemite National Park, Appendix 2.A.1, “Flow Estimation Calculations Sheet” Project No. 0570010*00 April 2, 2008.

Mathematical modeling of sewer flows were estimated using the design criteria in association with the land use and user/connection information provided from YNP. The theoretical sewer flow of the main sewer collection trunk mains can be evaluated using the computed peak sewer flows. In larger sewer basins, a dynamic model may be necessary to more accurately define the sewer flows if the spreadsheet analysis indicates a capacity problem. However, extensive data collection is required for mathematical modeling to include sewer pipe flow characteristics (e.g. pipe size, manhole invert elevations to a base datum, piping materials, etc.). Simple spreadsheet calculations using the “User Description” criteria presented in Table 8.1 should be adequate for determining expected design flows for El Portal.

YOSEMITE NATIONAL PARK UTILITIES BRANCH

SEWER SYSTEM MANAGEMENT PLAN EL PORTAL SANITARY SEWER SYSTEM (CS 5SSO10735)

TABLE 8.1
Sewer Design Flow Criteria for El Portal - YNP

User Description	Typical Sewer Design Flow
House	176 gallons per day per unit ¹
Apartment	240 gallons per day per unit ¹
Mobil Home	140 gallons per day per unit ¹
Laundry Room (3 washers 3 dryers)	1,350 gallons per day per unit ¹
School	2,310 gallons per day per unit ¹
Park with Restroom	375 gallons per day per unit ¹
Day Care	405 gallons per day per unit ¹
Post Office	13 gallons per day per unit ¹
Community Hall	892 gallons per day per unit ¹
Fire Station 1	13 gallons per day per unit ¹
Fire Station 2	351 gallons per day per unit ¹
Yosemite Institute	390 gallons per day per unit ¹
Yosemite Association	117 gallons per day per unit ¹
Market	30 gallons per day per unit ¹
12 Parking Spots – 1 unit	24 gallons per day per unit ¹
Gas Station Employees	13 gallons per day per unit ¹
Gas Station Vehicles served – 1 unit	300 gallons per day per unit ¹
Motor Inn Cabins	120 gallons per day per unit ¹
Bulk Plant	39 gallons per day per unit ¹

YOSEMITE NATIONAL PARK UTILITIES BRANCH

SEWER SYSTEM MANAGEMENT PLAN EL PORTAL SANITARY SEWER SYSTEM (CS 5SSO10735)

**TABLE 8.1 (Continued)
Sewer Design Flow Criteria for El Portal - YNP**

User Description	Typical Sewer Design Flow
Human Resource Buildings – 1 unit	65 gallons per day per unit ¹
Rangers' Office	156 gallons per day per unit ¹
Wash Basin	11.4 gallons per person per day ²
Flushable Toilets	9-19 gallons per person per day ²
Shower	11-13 gallons per person per day ²
Source: ¹ Kennedy/Jenks Consultants - Volume 2 El Portal Sanitary Sewer System Capital Improvement Plan, Yosemite National Park, Appendix 2.A.1, "Flow Estimation Calculations Sheet" Project No. 0570010*00 April 2, 2008 ² Wastewater Engineering, Treatment/Disposal/Reuse by Metcalf & Eddy.	

Table 8.2-A is not completed at this time as sewer flow measurements are not scheduled for the maintenance area portion of the system because of the low number of water fixtures (i.e. toilets and sinks) serving this area as well as no recorded SSO events. Table 8.2-B through Table 8.2-H presented below gives sewer design flow values in gallons per day (GPD) for each user description in El Portal Basin 2 through Basin 8. Table 8.1 values provided by Kennedy/Jenks Consultants and Wastewater Engineering, Treatment/Disposal/Reuse by Metcalf & Eddy result in a sewer design flow description of basins 2 through 8 and a cumulative flow of 205,934 gallons per day to the sewage treatment facility. However, it should be understood that actual sewer flow measurements will need to be performed to determine the actual capacity of any given pipe within the system

YOSEMITE NATIONAL PARK UTILITIES BRANCH

SEWER SYSTEM MANAGEMENT PLAN
EL PORTAL
SANITARY SEWER SYSTEM (CS 5SSO10735)

TABLE 8.2 – A
Sewer Collection Basin No. 1 – Maintenance Area

Description	Quantity	Type	Rate gpd/Type	Sum (GPD)
Maintenance Area	1	Unit	xxx	xxx
			TOTAL	xxx

TABLE 8.2 – B
Sewer Collection Basin No. 2 – Rancheria Flat

Description	Quantity	Type	Rate gpd/Type	Sum (GPD)
House	30	Unit	176	5,280
Apartment	12	Unit	240	2,880
Park with Restrooms	1	Unit	375	375
School	1	Unit	2,310	2,310
Day Care	1	Unit	405	405
			TOTAL	11,250

YOSEMITE NATIONAL PARK UTILITIES BRANCH

SEWER SYSTEM MANAGEMENT PLAN
EL PORTAL
SANITARY SEWER SYSTEM (CS 5SSO10735)

TABLE 8.2 – C
Sewer Collection Basin No. 3 – Rancheria Flat

Description	Quantity	Type	Rate gpd/Type	Sum (GPD)
House	6	Unit	176	1,056
Apartment	16	Unit	240	3,840
			TOTAL	4,896

TABLE 8.2 – D
Sewer Collection Basin No. 4 – Rancheria Flat

Description	Quantity	Type	Rate gpd/Type	Sum (GPD)
House	1	Unit	176	176
Apartment	34	Unit	240	8,160
			TOTAL	8,336

YOSEMITE NATIONAL PARK UTILITIES BRANCH

SEWER SYSTEM MANAGEMENT PLAN EL PORTAL SANITARY SEWER SYSTEM (CS 5SSO10735)

**TABLE 8.2 – E
Sewer Collection Basin No. 5 – Trailer Court**

Description	Quantity	Type	Rate gpd/Type	Sum (GPD)
Mobile Home	30	Unit	140	4,200
Laundry Room (3 washers, 3 dryers)	1	Unit	1,350	1,350
			TOTAL	5,550

**TABLE 8.2 – F
Sewer Collection Basin No. 6 – Old El Portal**

Description	Quantity	Type	Rate gpd/Type	Sum (GPD)
House	58	Unit	176	10,208
Fire Station 1	1	Unit	13	13
Fire Station 2	1	Unit	351	351
Rangers' Office	1	Unit	156	156
Yosemite Institute	1	Unit	390	390
Yosemite Association	1	Unit	117	117
Market	1	Unit	30	30
12 Parking Spots – 1 unit	1	Unit	24	24
Gas Station Employees	1	Unit	13	13
Gas Station Vehicles served – 1 unit	1	Unit	300	300
Motor Inn Cabins	23	Unit	120	2,760
Bulk Plant	1	Unit	39	39
Human Resource Buildings	1	Unit	65	65

YOSEMITE NATIONAL PARK UTILITIES BRANCH

SEWER SYSTEM MANAGEMENT PLAN

EL PORTAL

SANITARY SEWER SYSTEM (CS 5SSO10735)

TABLE 8.2 – F (Continued)
Sewer Collection Basin No. 6 – Old El Portal

Description	Quantity	Type	Rate gpd/Type	Sum (GPD)
Community Hall	1	Unit	892	892
Post Office	2	Unit	13	26
3 Washers/3 Dryers – Building 771	1	Unit	1,350	1,350
TOTAL				16,734

TABLE 8.2 – G
Sewer Collection Basin No. 7 – Old El Portal

Description	Quantity	Type	Rate gpd/Type	Sum (GPD)
House	23	Unit	176	4,048
TOTAL				4,048

TABLE 8.2 – H
Sewer Collection Basin No. 8 – Yosemite View Lodge

Description	Quantity	Type	Rate gpd/Type	Sum (GPD)
Yosemite View Lodge	1	Unit	155,520	155,520
TOTAL				155,520

YOSEMITE NATIONAL PARK UTILITIES BRANCH

SEWER SYSTEM MANAGEMENT PLAN

EL PORTAL

SANITARY SEWER SYSTEM (CS 5SSO10735)

8.2.3 ACTUAL SEWER FLOW MEASUREMENT

The hydraulic sewer capacity of a collection system is considered limiting when the depth of sewer pipe flow exceeds 2/3's of the pipe diameter. Flow should not exceed 2/3's of the pipe diameter under any of the following flow events: Average day dry weather, Average day wet weather, Peak day wet weather, or Peak hour. This 2/3's pipe diameter criteria is commonly applied by municipalities, but may be adjusted. The actual sewer flow capacity assessment includes:

1. Field manhole inspections and flow measurements to determine if pipe segments are approaching their hydraulic limits and to help qualify the source for high sewer flows.
2. Comparison of actual sewer flow measurements with calculated theoretical sewer flow data to determine whether field measured sewer flows exceed expected design flows.
3. If measured sewer flows exceed expected design flows, further investigation will be required to determine whether the source of the excess sewer flow can be controlled and/or whether sewer enhancement projects are required. However, a detailed inflow and infiltration (I&I) study may also be required if I&I cannot be ascertained with field manhole inspections and manhole sewer flow measurements, to be determined by the Design and Engineering Branch of the Division of Facilities Management.
4. Maintain good maintenance records documenting frequent maintenance issues.

Sewer observations and flow measurements are initially taken at pre-designated manhole locations that have been strategically selected within a sub basin to best segment the sewer collection system into manageable sewer service areas, sewer mains, and/or sewer laterals. Subsequent sewer flow measurements will be taken at other manhole locations following the assessment of data initially collected at the pre-designated manhole locations. See Section 8.2.5 for procedural details. Suspected sewer capacity issues noted during the 2009 closed circuit television (CCTV) inspections were considered in the initial selection of the pre-designated sewer flow measurement locations discussed in Section 8.2.5. Sewer flow measurements should

YOSEMITE NATIONAL PARK UTILITIES BRANCH

SEWER SYSTEM MANAGEMENT PLAN

EL PORTAL

SANITARY SEWER SYSTEM (CS 5SSO10735)

only be required initially to identify sewer capacity limiting conditions that cause SSOs and thereafter only if 1) subsequent sewer system improvements are not successful in controlling SSOs or if 2) sewer flows have increased resulting from I&I or local property developments.

A combination of sewer manhole observations and sewer flow measurements are to be made at pre-designated manhole locations to document the following; flow conditions through the manhole, condition of piping where it joins manhole, system performance, and the potential I&I contributions. The YNP has acquired the Marsh-McBirney FLO-DAR Sensor, HACH FL 900 Series Flow Logger, and Flo-Ware software to measure, assimilate, and record sewer flows. Distinct advantages with this system are its accuracy in open-channel flow monitoring, ease of operation, and its battery operated portability. The FLO-DAR Sensor utilizes a radar sensor for measuring velocity of sewer flow and an ultrasonic sensor for measuring water depth. Sewer flows are then determined/calculated based on the continuity equation (i.e. average velocity x cross sectional area = flow volume). Examples of the Flo-Ware reports are presented in Table 8.3 and Figure 8.2. The FLO-DAR Sensor also has sensors to report sewer manhole surcharges that may result during peak flows or sewer blockages. The FL-900 Logger stores all data collected by the FLO-DAR Sensor and the Flo-Ware Windows software manages and reports the measured flow depths, measured flow velocity, and calculated flows for each pre-designated period of instrument operation in tabular or plotted format. The manufacturer recommends recording flows at 15 minute intervals which should capture peak flows and provide maximum battery life, but the frequency may be adjusted to one (1) minute per reading if more sensitive flow readings are desired. Daily and weekly minimum flow, daily and weekly maximum flow, daily and weekly average flow, and accumulated daily and weekly flows will be reported by the FL-900 Logger. This data should be summarized on worksheets presented in Tables 8.5 –A, –B, –C, –D and –E. Given the size of El Portal's sewer system and other systems within YNP, multiple data loggers should be used to expedite completion of the Capacity Assurance Plan. Only NPS personnel or contractors trained in proper equipment set-up and operation of the FLO-DAR and FL-900 Logger as well as data management with the Flo-Ware software should be utilized. **Additionally, all field workers shall be trained in traffic management and security as well as health and safety procedures including exposure to wastewater and confined space entry.**

YOSEMITE NATIONAL PARK UTILITIES BRANCH

SEWER SYSTEM MANAGEMENT PLAN EL PORTAL SANITARY SEWER SYSTEM (CS 5SSO10735)

TABLE 8.3
Example of Tabular Flow Data by Flo-Ware

Flow Report

Units: Flow / Totals: Gallons

Date	Max	Min	Avg	Total	Week 1 Summary	Max	Min	Avg	Total
08/01/11									
08/02/11									
08/03/11									
08/04/11									
08/05/11									
08/06/11									
08/07/11					Week 2 Summary	Max	Min	Avg	Total
08/08/11									
08/09/11									
08/10/11									
08/11/11	77.98	0.00	16.52	23,790.77					
08/12/11	84.01	0.00	8.88	12,792.31					
08/13/11	75.13	0.00	5.55	7,995.37					
08/14/11	46.22	0.00	2.97	4,275.66	Week 3 Summary	Max	Min	Avg	Total
08/15/11	63.39	0.00	14.18	20,414.09		84.01	0.00	9.62	69,268.20

YOSEMITE NATIONAL PARK UTILITIES BRANCH

SEWER SYSTEM MANAGEMENT PLAN

EL PORTAL

SANITARY SEWER SYSTEM (CS 5SSO10735)

FIGURE 8.2
Example of Plotted Flow Data by Flo-Ware

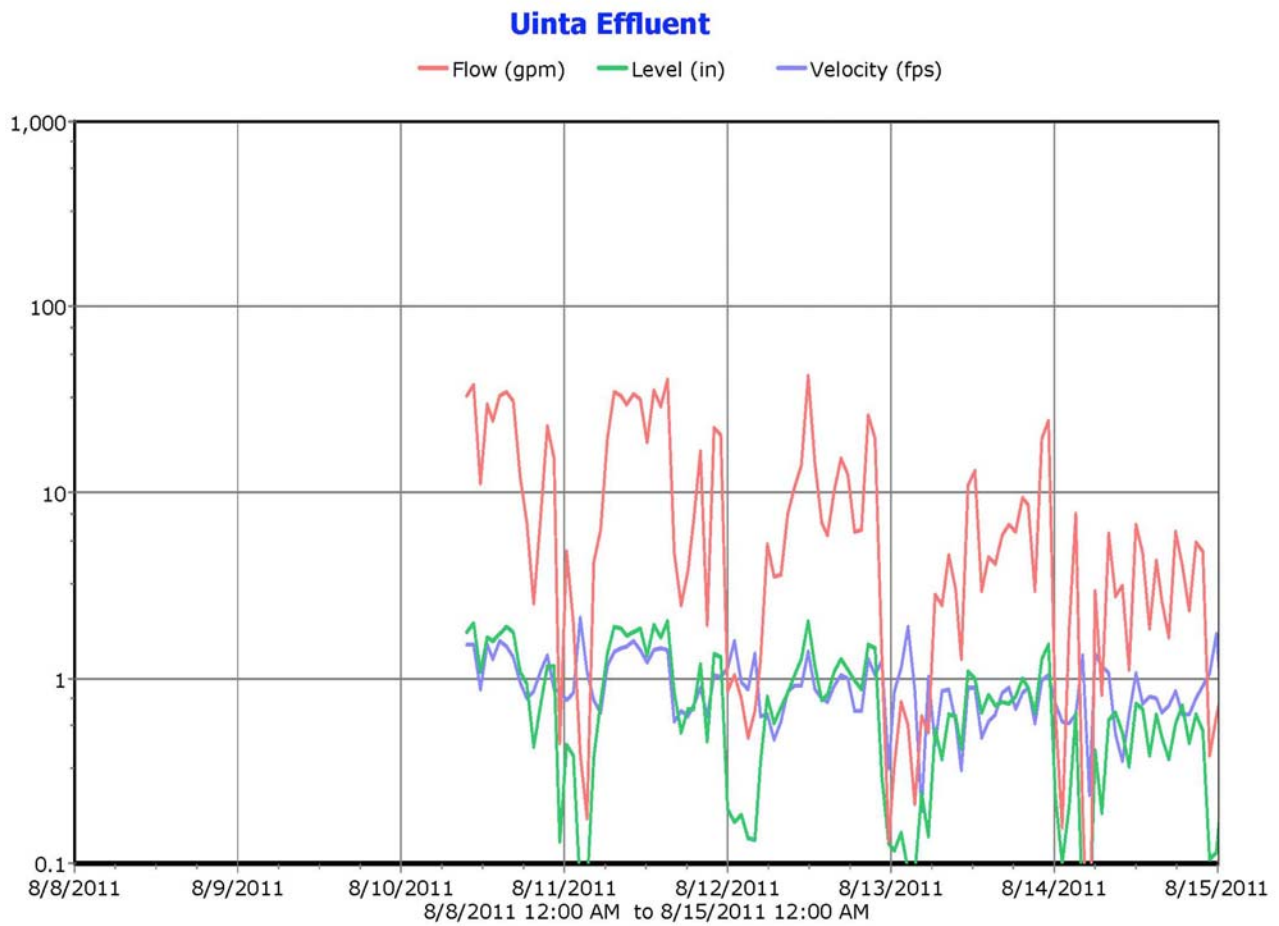

YOSEMITE NATIONAL PARK UTILITIES BRANCH

SEWER SYSTEM MANAGEMENT PLAN

EL PORTAL

SANITARY SEWER SYSTEM (CS 5SSO10735)

8.2.4 INFILTRATION AND INFLOW CONSIDERATIONS

Sewer flows from a combination of domestic sewer flows and/or infiltration and inflow (I&I) should be considered during the assessment. State Water Resource Control Board Order No. 2006-0003 requires hydraulic capacity assessments for dry weather peak flow conditions as well as a design for storm or wet weather events. Table 8.4 presents a 30-year summary of the seasonal precipitation events for YNP, whereas dry weather flows will likely occur during July or August and wet weather events will likely occur during January, February, or March. However, peak sewer flows may occur when infiltration is greatest during high groundwater or high river flows. Since the primary objective for hydraulic capacity assessment is to determine the peak sewer flow and its apparent source (i.e., precipitation events, runoff events, or maximum site usage during dry weather), seasonal sewer manhole observations may be required for large sewer systems to help determine the optimal periods for sewer flow measurements. Sewer hydraulic capacity is often exceeded during maximum I&I conditions, but I&I typically varies throughout the year with rainfall and runoff.

Given the size of El Portal’s system and year round use, seasonal sewer manhole observations should be required.

TABLE 8.4
Thirty Year Summary of US Weather Service Data at
Yosemite National Park Headquarters
 (Elevation 3966 ft msl)

30 Year Normals (1971 – 2000)																
Month		Jan	Feb	Mar	Apr	May	Jun	Jul	Aug	Sep	Oct	Nov	Dec	Ann	Month	
N O R M A L	Maximum	47.5	52.8	57.4	64.7	72.1	81.6	89.9	90.6	84.2	73.2	57.2	47.9	68.3	Maximum	N O R M A L
	Minimum	27.8	29.8	33.1	37.4	43.2	49.8	55.4	54.6	49.4	41.1	31.8	27.2	40.1	Minimum	
	Precipitation	6.73	6.92	5.80	2.57	1.58	0.79	0.51	0.21	0.92	2.27	4.66	4.77	37.73	Precipitation	
Degree Days	Heating	849	664	612	429	266	88	16	13	74	283	614	851	4759	Heating	Degree Days
	Cooling	0	0	0	11	37	110	254	249	128	39	0	0	828	Cooling	

YOSEMITE NATIONAL PARK UTILITIES BRANCH

SEWER SYSTEM MANAGEMENT PLAN

EL PORTAL

SANITARY SEWER SYSTEM (CS 5SSO10735)

The estimated hydraulic capacity of the sewer collection system is a function of the number of sewer users (i.e. campers, visitors, residences, and commercial establishments) and I&I, which is associated with the condition of the sewer component(s) (i.e. size, type and condition of material, energy gradient or pipe slope, etc.) Infiltration enters the sewer system through openings such as: displaced or open pipe joints; cracks, fractures and breaks in the fabric of the main sewer and lateral connections, and manhole chambers. Maximum infiltration typically occurs during periods of high groundwater caused from snow melt, spring runoff, precipitation, and/or irrigation. However, there is little surface irrigation within Yosemite National Park; therefore, irrigation has a negligible effect upon high groundwater and infiltration potential. Snow melt, spring runoff, and precipitation events are the principal influences for high groundwater which may correlate with river flow. The Merced River flows adjacent to the El Portal sewer system. Approximately nine miles upstream at Pohono Bridge there is a stream gage that may be representative of runoff and high groundwater affecting the El Portal system. Historical flow data for the Merced River, summarized graphically in Figure 8.3 indicates high Merced River flows from runoff during May through June with peak runoff in May. Therefore, sewer flow measurements intending to identify infiltration conditions should occur during May and/or June. Currently, the 2009 CCTV report shows five pipe segments with infiltration stains. Four infiltration stains are located in Old El Portal and one is located in Rancheria Flat.

Inflow results from faulty manhole covers, improper sewer connections such as downspouts and groundwater sump pumps that discharge water into the sewer system, and surface water sewers/drains or land drainage connections. An oil/water separator in the equipment maintenance facility and another oil/water separator located at the gas station are connected to the sanitary sewer system and contribute minor inflow into the system. They are properly designed to pre-treat contaminated waters discharging into the sanitary sewer and are not expected to be a cause of capacity issues at El Portal. Through periodic inspection, sewer inflows resulting from faulty manhole covers at El Portal can be prevented. There are no known improper sewer connections such as downspouts, groundwater sump pumps that discharge water into the sewer system or surface water sewers/drains or land drainage connections to El Portal sewer system to contribute inflow. Any future inflow sources of suspect cause as mentioned above may be traced using smoke or dye testing procedures, but inflow sources beyond the oil/water separator are not currently suspected at El Portal.

YOSEMITE NATIONAL PARK UTILITIES BRANCH

SEWER SYSTEM MANAGEMENT PLAN EL PORTAL SANITARY SEWER SYSTEM (CS 5SSO10735)

FIGURE 8.3
Summary of Peak Runoff Flows for the Merced River from 1969 through 2010

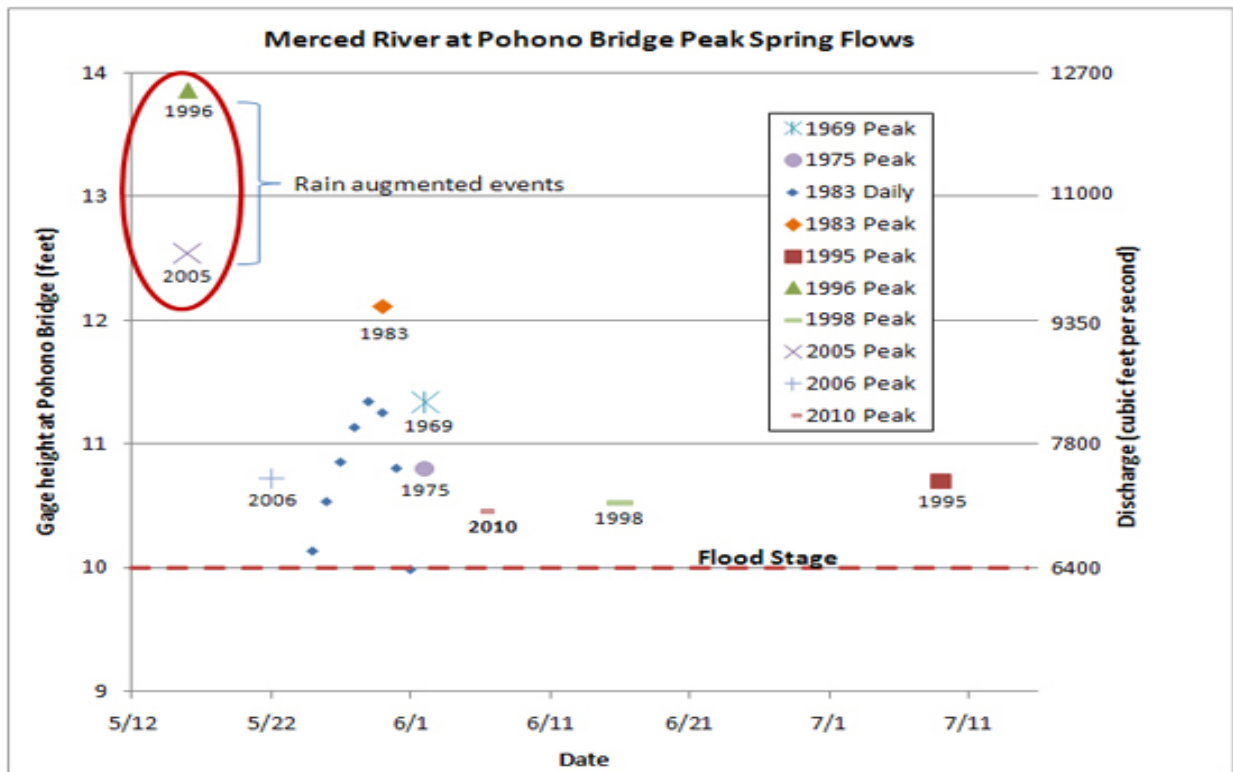

YOSEMITE NATIONAL PARK UTILITIES BRANCH

SEWER SYSTEM MANAGEMENT PLAN

EL PORTAL

SANITARY SEWER SYSTEM (CS 5SSO10735)

8.2.5 SITE SPECIFIC PROCEDURES FOR MEASURING SEWER FLOWS AT RANCHERIA FLAT, TRAILER COURT, OLD EL PORTAL AND YOSEMITE VIEW LODGE

The overall underlying priority is to inspect and monitor the flow of the sewer collection system at locations that have experienced or contributed to an SSO discharge, as discussed in this Section, within the last five years. The following two methods are procedures for providing subsequent inspection and flow monitoring of sewer lines to determine how and where flow monitoring should be performed. These procedures will be used implicitly throughout the El Portal sewer system unless stated otherwise.

The bisection method: This method is used when a sewer main line has ancillary mains contributing flows into upstream manholes and the main line is relatively long. Segments having capacity limitations can be found efficiently by looking at the entire main line. Based on the outcome of initial visual inspections, the line is bisected into segments with inspections and monitoring performed at manholes having ancillary mains. In utilizing this method, one can determine whether the main line needs to be bisected further, either up or down the main line based upon the monitored flow depth. Refer to the example shown below in Figure 8.4. One can also determine whether or not an ancillary main line needs to be investigated along with or instead of the primary main.

The stepped method – walking up or down the segments: This method is used when a sewer main line has little or no significant contribution from ancillary mains or laterals coming into upstream manholes, or the main line itself is short with only a few manholes along the pipeline. In this situation, segments having capacity limitations can be found efficiently by inspection/monitoring each pipe segment up, or down, the main line. Refer to the example shown below in Figure 8.5. This method can also be performed during the bisection method near the end when only a few manholes remain within a bisected section and the manholes receive little or no contribution and proceeding with visual inspection one manhole at a time may be most efficient.

FIGURES 8.4 & 8.5 Bisection Method and Stepped Method Examples

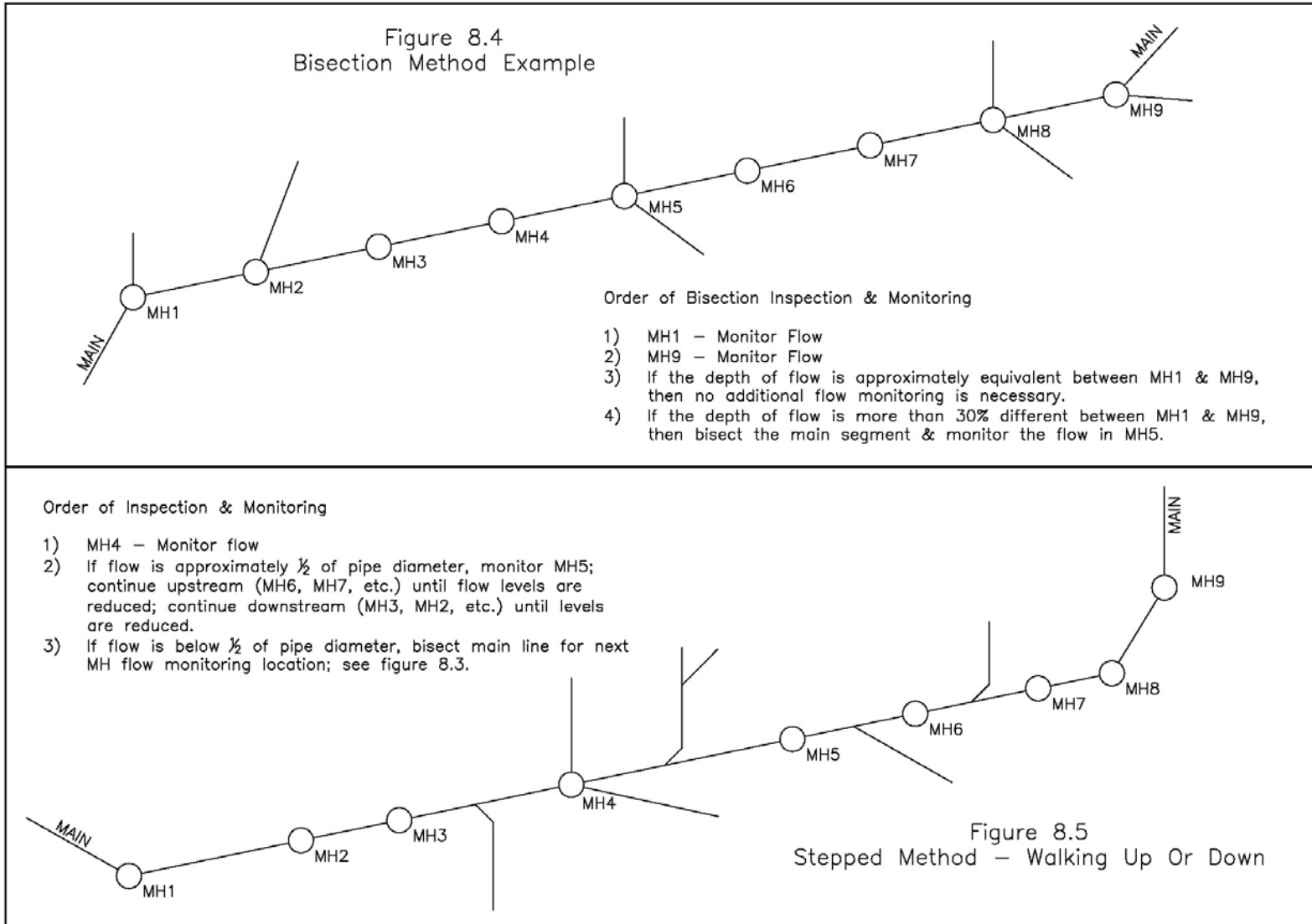

YOSEMITE NATIONAL PARK UTILITIES BRANCH

SEWER SYSTEM MANAGEMENT PLAN EL PORTAL SANITARY SEWER SYSTEM (CS 5SSO10735)

Prior to monitoring the system, manhole selection should be based on a preliminary estimate of the hydraulic capacity of the key sanitary sewer system elements, within each basin or sub basin, based on the operational experience of the YOSE Staff, documented SSO's, and other circumstantial documentation, as discussed in this Section. Measurement of inlet flows into the manhole should be performed over measurement of outlet flows whenever possible. YNP will determine the hydraulic capacity of the key sanitary sewer system elements by measuring the actual depth of sewer flow in the system for the following collection systems.

The El Portal sewer system has eight basins that service separate sewer collection systems as shown in Figure 8.1 and described in subsequent sections.

Six SSO events have occurred within the last five years and they were due to grease, and or debris blockage and lift station pump failure. There are pipe segments that experienced blockage or had irregularities that caused surveys to be abandoned or the camera was underwater during the 2009 CCTV inspections and these segments should be monitored in detail.

El Portal has a system of sewer lines that utilize seven lift stations. These include:

- A. One large and one small lift station are located in the Maintenance Complex area.
- B. One large lift station in Abbyville serving the Trailer Court/Park area.
- C. Four (4) small capacity lift stations serving the Motor Inn, El Portal Market, Resource Management & Science building and the Petroleum bulk plant respectively.

For large and medium lift stations, sewer flow measurements should begin either at the lift station or the first manhole upstream when possible. Lift Station pump data should be obtained with a Lift Station hour meter recorded concurrently with the initial flow monitoring to determine total flow between the initial manhole measured flow and the Lift Station. This will be used along with expected inflow from the upstream segments to identify the quantity of reported infiltration of these sewer segments. This will also provide calibration of the Lift Station to be used to assess subsequent flow information.

YOSEMITE NATIONAL PARK UTILITIES BRANCH

SEWER SYSTEM MANAGEMENT PLAN

EL PORTAL

SANITARY SEWER SYSTEM (CS 5SSO10735)

A. SEWER COLLECTION BASIN NO. 1 – MAINTENANCE AREA

As discussed in Section 4, the sewer collection system within the El Portal Maintenance Complex, as mapped in Figure 4.3, services various administrative and maintenance facilities supporting YNP activities. The facilities include park administration buildings, vehicle and equipment storage, warehouses for material storage, and various maintenance shops to support roads and trails, high voltage, telecom, forestry, locksmith, signs, building and grounds, historic preservation, and vehicle maintenance.

The sewer system for the maintenance complex includes approximately 5 manholes, 1,150 linear feet (lf) of 6-inch diameter gravity sewer main, an oil/water separator in the equipment maintenance facility, a lift station with 350 lf of 3 inch diameter force main that pumps wastewater from the administrative offices to a manhole near the northern corner of building 759, and a lift station with 400 lf of 4 inch diameter force main that pumps all Maintenance Complex wastewater to the El Portal wastewater treatment facility.

Sewer flow measurements are not scheduled for this portion of the system because of the low number of water fixtures (i.e. toilets and sinks) serving this area as well as no recorded SSO events, but sewer flow observations in manholes should be reported during the MH inspections as scheduled in Section 4.0 to confirm that no sewer hydraulic capacity issues exist. The manhole observations should be documented in Table 8.5E and Table 8.6.

B. SEWER COLLECTION – RANCHERIA FLAT

The Rancheria Flat sewer system services a small community consisting of approximately 62 apartment units, 42 single family dwellings, community pool, tennis court facility, and public school and library with restrooms with approximately 340 linear feet of 8" piping, 6,750 linear feet of 6" piping and 75 linear feet of 4" piping and seventy seven (77) manholes. Pipe capacity issues have been experienced in the past due to pipe and root blockages and were noted during the 2009 CCTV inspection that showed significant cracking, fractures and breaks in VCP piping including deviations in sewer alignment and significant root growth.

YOSEMITE NATIONAL PARK UTILITIES BRANCH

SEWER SYSTEM MANAGEMENT PLAN

EL PORTAL

SANITARY SEWER SYSTEM (CS 5SSO10735)

B.I SEWER COLLECTION BASIN NO. 2 – RANCHERIA FLAT

Monitor RF13 to report total sewer flow from the Rancheria Flat Road area sewer line as well as the respective hourly peaks.

Upstream MH: ID RF12 Rim = xx.xx; Inv = xx.xx	Downstream MH: ID RF13 Rim = xx.xx; Inv = xx.xx
Pipe: Dia = 6"; Length = 164 ft; Manning's n (DIP) = 0.015; Slope = 0.xxxx	
Flow Criteria: d/D = 2/3; Qcap (based on d/D = 2/3) = xx.x gpm	

The sewer flow for this pipe segment should not exceed xxx gpm.

Monitor RF7 to acquire sewer flow from the upstream residential and recreational area as well as the respective hourly peaks. Although I&I is unlikely in Rancheria Flats due to terrain characteristics, it should be considered during inspections. A comparison of sewer flow measurements and presence of I&I will indicate whether areas or manhole locations upstream or downstream should be monitored. If little or no I&I is present and pipe capacity observations or measurements indicate piping are flowing at less than 2/3's full, then no further sewer flow measurements are required.

B.II SEWER COLLECTION BASIN NO. 3 – RANCHERIA FLAT

Monitor RF14 to report total sewer flow from the Rancheria Flat Road area sewer line as well as the respective hourly peaks.

Upstream MH: ID RF22 Rim = xx.xx; Inv = xx.xx	Downstream MH: ID RF14 Rim = xx.xx; Inv = xx.xx
Pipe: Dia = 6"; Length = 156 ft; Manning's n (DIP) = 0.015; Slope = 0.xxxx	
Flow Criteria: d/D = 2/3; Qcap (based on d/D = 2/3) = xx.x gpm	

The sewer flow for this pipe segment should not exceed xxx gpm. The remaining upstream pipe line segments should be measured for flows utilizing a stepped method.

YOSEMITE NATIONAL PARK UTILITIES BRANCH

SEWER SYSTEM MANAGEMENT PLAN

EL PORTAL

SANITARY SEWER SYSTEM (CS 5SSO10735)

B.III SEWER COLLECTION BASIN NO. 4 – RANCHERIA FLAT

Monitor RF33 to determine total sewer flow leading up to the Barium Mine Road residential sewer line as well as the respective hourly peaks.

Upstream MH: ID RF32 Rim = xx.xx; Inv = xx.xx	Downstream MH: ID RF33 Rim = xx.xx; Inv = xx.xx
Pipe: Dia = 6"; Length = 54 ft; Manning's n (VCP) = 0.015; Slope = 0.xxxx	
Flow Criteria: d/D = 2/3; Qcap (based on d/D = 2/3) = xx.x gpm	

The sewer flow for this pipe segment should not exceed xxx gpm.

An SSO event in the Rancheria Flat area within the last five years occurred along the pipe line segment between manholes RF28 and RF29 due to root blockage and should be inspected. The remaining upstream pipe line segments should be measured for flows utilizing a stepped method.

Sewer flow measurement data for manholes RF13, RF7, RF14, and RF33 should be documented on the forms presented in Tables 8.5A and 8.6. Additional manhole sewer flow measurements can be recorded using the same format as presented in Table 8.5-E.

C. SEWER COLLECTION BASIN NO. 5 – TRAILER COURT

The Trailer Court sewer system serves a couple residential structural dwellings, and 19 to 20 permanent double wide residential trailers with approximately 4,120 linear feet of 6" sewer piping and 30 manholes. The Trailer Court has a greater likelihood to be impacted from I&I than the Rancheria Flat's sewer system as the gradients are much less. Lift Station pump data should be obtained with a Lift Station hour meter recorded concurrently with the initial flow monitoring to determine total flow between manhole TP17 measured flow and the Lift Station. This will be used along with expected inflow from the upstream segments to identify the quantity of reported infiltration of these sewer laterals. This will also provide calibration of the Lift Station to be used to assess subsequent flow information.

YOSEMITE NATIONAL PARK UTILITIES BRANCH

SEWER SYSTEM MANAGEMENT PLAN

EL PORTAL

SANITARY SEWER SYSTEM (CS 5SSO10735)

Monitor TP18 to report total sewer flow from the Trailer Court sewer system as well as the respective hourly peaks.

Upstream MH: ID TP17 Rim = xx.xx; Inv = xx.xx	Downstream MH: ID TP18 Rim = xx.xx; Inv = xx.xx
Pipe: Dia = 6"; Length = 85 ft; Manning's n (DIP) = 0.015; Slope = 0.xxxx	
Flow Criteria: d/D = 2/3; Qcap (based on d/D = 2/3) = xx.x gpm	

The sewer flow for this pipe segment should not exceed xxx gpm. Flow rates should be determined using Lift Station pump data obtained with the hour meter recorded concurrently with the initial TP18 flow monitoring to determine total flow between TP18 and the Lift Station. This will be used along with expected inflow from the residential buildings to identify the quantity of reported infiltration of these sewer laterals. This information can be used as an indicator for potential upstream capacity and during weekly Lift Station inspections to determine if the operator should investigate a capacity concern.

Monitor manhole TP7 to report total sewer flow from the Trailer Court sewer system as well as the respective hourly peaks. A comparison of sewer flow measurements and their suspected I&I will indicate whether other areas or manhole locations within the Trailer Court sewer system should be monitored. If little I&I is present and pipe capacity observations or measurements indicate piping are flowing at less than 2/3's full, then no further sewer flow measurements are required.

Sewer flow measurement data for manholes TP18, and TP7 should be documented on the forms presented in Tables 8.5B and 8.6. Additional manhole sewer flow measurements can be recorded using the same format presented in Table 8.5-E.

YOSEMITE NATIONAL PARK UTILITIES BRANCH

SEWER SYSTEM MANAGEMENT PLAN

EL PORTAL

SANITARY SEWER SYSTEM (CS 5SSO10735)

D. SEWER COLLECTION – OLD EL PORTAL

The Old El Portal sewer system serves residences, and other facilities both public and private that include a gas station, market, old hotel, motor inn cabins, office building and a train exhibit with approximately 7,984 linear feet of 6" sewer piping, 909 linear feet of 4" sewer piping and 41 linear feet of 3" sewer piping and 94 manholes. Piping and manhole counts are per inventoried asset numbers. See figures 4.6 through 4.8. Old El Portal has two separate sewer lines that connect to the 16" main flowing to the El Portal waste water treatment facility. Sewer flow measurements for each of these lines should be taken close to where manholes join with the 15" main. SSO occurrences within the last five years include segments between manholes EP47 to EP 48, EP31 to EP32, EP30 to EP3001 and EP3001 to EP3002. After initial flow measurements have been taken near the 15" main connection, segments known to have SSOs should be inspected and flow measured to report total sewer flow as well as the respective hourly peaks.

D.1 SEWER COLLECTION BASIN NO. 6 – OLD EL PORTAL

Monitor manhole EP33 to report total sewer flow from the Foresta Road area sewer line as well as the respective hourly peaks.

Upstream MH: ID EP32 Rim = xx.xx; Inv = xx.xx	Downstream MH: ID EP33 Rim = xx.xx; Inv = xx.xx
Pipe: Dia = 6"; Length = 102 ft; Manning's n (DIP & conc) = 0.015 & 0.013; Slope = 0.xxxx	
Flow Criteria: d/D = 2/3; Qcap (based on d/D = 2/3) = xx.x gpm	

The sewer flow for this pipe segment should not exceed xxx gpm.

Monitor manhole EP30 to report total sewer flow as well as the respective hourly peaks. Using the stepped method, walk up the segments throughout the known SSO problem areas. If little I&I is present and pipe capacity observations or measurements indicate piping are flowing at less than 2/3's full, then no further sewer flow measurements are required.

YOSEMITE NATIONAL PARK UTILITIES BRANCH

SEWER SYSTEM MANAGEMENT PLAN

EL PORTAL

SANITARY SEWER SYSTEM (CS 5SSO10735)

Sewer flow measurement data for manholes EP33 and EP30 should be documented on the forms presented in Tables 8.5C and 8.6. Additional manhole sewer flow measurements can be recorded using the same format as presented in Table 8.5-E.

D.II SEWER COLLECTION BASIN NO. 7 – OLD EL PORTAL

Monitor manhole EP49 to report total sewer flow from the Foresta Road area sewer line as well as the respective hourly peaks.

Upstream MH: ID EP48 Rim = xx.xx; Inv = xx.xx	Downstream MH: ID EP49 Rim = xx.xx; Inv = xx.xx
Pipe: Dia = 6"; Length = 49 ft; Manning's n (DIP & conc) = 0.015 & 0.013; Slope = 0.xxxx	
Flow Criteria: d/D = 2/3; Qcap (based on d/D = 2/3) = xx.x gpm	

The sewer flow for this pipe segment should not exceed xxx gpm.

Monitor manhole EP48 to determine total sewer flow as well as the respective hourly peaks. Pipe segment EP48 to EP 47 experienced an SSO within the last five years. A comparison of sewer flow measurements and their suspected I&I will indicate whether other areas or manhole locations within the Old El Portal sewer system should be monitored. If little I&I is present and pipe capacity observations or measurements indicate piping are flowing at less than 2/3's full, then no further sewer flow measurements are required.

Sewer flow measurement data for manholes EP49 and EP48 should be documented on the forms presented in Tables 8.5C and 8.6. Additional manhole sewer flow measurements can be recorded using the same format as presented in Table 8.5-E.

YOSEMITE NATIONAL PARK UTILITIES BRANCH

SEWER SYSTEM MANAGEMENT PLAN

EL PORTAL

SANITARY SEWER SYSTEM (CS 5SSO10735)

E. SEWER COLLECTION BASIN NO. 8 – YOSEMITE VIEW LODGE

Yosemite View Lodge discharges effluent from facilities that include 336 guest rooms, two restaurants, a bar, gift shop/convenience mart, four swimming pools, seven spas, and a coin operated laundry room.³ Flow measurement should be monitored at MH48 to report total sewer flow from the lodge's sewer line as well as the respective hourly peaks. If the operator has satisfactorily identified any contributing I&I and/or pipes flowing more than 2/3's full, coordination to remedy any SSO potential should take place between the Yosemite View Lodge personnel and YNP Utilities personnel. Sewer flow measurement data for manhole MH48, should be documented on the forms presented in Tables 8.5D and 8.6. Additional manhole sewer flow measurements can be recorded using the same format as presented in Table 8.5-E.

Note that data assessment and comparison should be performed by qualified and trained personnel who will conclude whether additional sewer flow measurements are required and at what locations. If I&I is present or if observations or measurements indicate the piping are flowing at more than 2/3's full, additional sewer flow measurements should be taken to further define the adverse condition. The selection of other manhole locations for additional sewer flow measurements should employ the observation of manholes upstream of the adverse condition to visually examine and determine if the adverse flow condition can be easily observed and measured. Using the bisection or stepped method for measuring sewer flows should continue until the operator has satisfactorily identified the pipe segment contributing to the I&I and/or pipes flowing more than 2/3's full.

Mapped locations of flow monitor testing are provided in Section 4, Figures 4.1 through 4.9.

3 (Reference: <http://www.stayyosemiteviewlodge.com>)

YOSEMITE NATIONAL PARK UTILITIES BRANCH

SEWER SYSTEM MANAGEMENT PLAN

EL PORTAL

SANITARY SEWER SYSTEM (CS 5SSO10735)

8.3 COMPARISON OF FIELD MEASUREMENTS AND DESIGN CRITERIA

The capacity evaluation requires the comparison of field measurements with design flows and/or mathematical models. However, detailed mathematical or sewer hydraulic models require extensive data to model field conditions and is expected to have limited benefit for the simple sewer collection system serving El Portal. A comparison of observed or measured sewer flow with design sewer flow is expected to qualify whether sewer capacity limiting conditions exist and if the conditions show I&I or undersized piping. Therefore, for El Portal, field measurements should be compared to simple empirical design calculations using the design data presented in Table 8.1 and the completion of the comparison summary presented in Tables 8.2-A through 8.2-H. A comparison of observed or measured sewer flow with design sewer flow is expected to qualify whether sewer capacity limiting conditions exist and if the conditions show I&I or undersized piping.

8.4 SEWER ENHANCEMENT

YNP will review the findings of the sewer assessment and determine whether sewer enhancement projects are necessary to address sewer capacity limiting conditions. Sewer flow data for El Portal is given in the report, "El Portal Sanitary Sewer CIP, Volume 2, by Kennedy Jenks, 2008" The 2009 CCTV results discussed in Section 4 do appear to indicate several areas of sewer capacity limiting conditions for the Rancheria Flat, and Old El Portal sewer systems. However, this conclusion must be re-evaluated following the collection of sewer flow data, as discussed in Section 8.2.3.

Sewer enhancement projects should utilize the design criteria presented in Table 8.1 and may require additional flow data and/or sewer system characterization to better define the sewer design components. Sewer enhancement projects will be included in the Capitol Improvement Plan (CIP) presented in Section 4.4 with YNP managers determining the level of need and priority for each sewer enhancement project.

However, it should be understood that increasing the frequency of maintenance may help to reduce or eliminate the need for a sewer enhancement project; therefore, YNP should consider and judge whether the sewer enhancement projects can be either delayed or prevented with the use of non-construction alternatives that prevent SSOs.

YOSEMITE NATIONAL PARK UTILITIES BRANCH

SEWER SYSTEM MANAGEMENT PLAN EL PORTAL SANITARY SEWER SYSTEM (CS 5SSO10735)

Yosemite National Park utilizes IBM's MAXIMO software for its FMSS for managing preventative and recurring maintenance and the issuance of work orders to document scheduled and conducted preventative maintenance activities as well as sewer enhancement projects and capital construction projects.

8.5 SCHEDULE

Presently, only Rancheria Flat, and Old El Portal sewer systems have 2009 CCTV results to assess sewer capacity; therefore, sewer flow measurements and additional manhole observations should be completed before reporting sewer limiting conditions. The sewer flow measurements and manhole observations should commence to collect data in early June when residential housing is near capacity and high infiltration is expected. The conclusions ascertained from the capacity evaluation and the development of sewer enhancement measures with cost estimates are expected to be completed following sewer flow measurements, whereas YNP should approve and prioritize sewer enhancement measures in the capital improvement plan. Modifications to this SECA are expected to be made as new information is learned and documented herein.

TABLE 8.5 – A
Observed and Measured Sewer Flow Data for
Rancheria Flat Sewer System – Basins 2, 3 & 4

Manhole Number	Pipe Diameter (inches)	Flow Direction ¹ (clock location of inlets and outlet)	Flow Measurement Period ²		Maximum Sewer Depth (inches or percent diameter)	Maximum Daily Flow		Minimum Daily Flow		Observations (e.g. date of presence of solids, sediments, foreign materials, roots, strong odors, water clarity)
			Start Date	Ending Date		(gpm)	(gpd)	(gpm)	(gpd)	
RF13	6	1 (in)								
RF13	6	5 (out)								
RF7	6	1 (in)								
RF7	6	7 (out)								
Action: If infiltration or 2/3 depth flow observed, proceed to RF7 for additional flow measurements. Report flow from RF13 and RF7 to USRO Supervisor to assess whether additional monitoring is required.										
RF14	6	3 (in)								
RF14	6	6 (out)								
Report flow from RF14 to USRO Supervisor to assess whether additional monitoring is required.										
LINE 3										
RF33	6	10 (in)								
RF33	6	4 (out)								
Report flow from RF33 to USRO Supervisor to assess whether additional monitoring is required.										
Notes:	(1): Pipe sizes and approximate flow directions are based on 2009 CCTV data and SSMP Figures 4.2 through 4.6. (2): Flow measurement periods to include weekend flows. Recommended minimum 5 days of flow measurements to include 3 week days and 2 weekend days. Additional week day flow measurements should be collected if schedule allows.									

TABLE 8.5 – B
Observed and Measured Sewer Flow Data for
Trailer Court Sewer System – Basin 5

Manhole Number	Pipe Diameter (inches)	Flow Direction ¹ (clock location of inlets and outlet)	Flow Measurement Period ²		Maximum Sewer Depth (inches or percent diameter)	Maximum Daily Flow		Minimum Daily Flow		Observations (e.g. date of presence of solids, sediments, foreign materials, roots, strong odors, water clarity)
			Start Date	Ending Date		(gpm)	(gpd)	(gpm)	(gpd)	
TP18	6	2 (in)								
TP18	6	8 (out)								
Action: If infiltration or 2/3 depth flow observed, proceed to TP7 for additional flow measurements.										
TP7	6	2 (in)								
TP7	6	5 (in)								
TP7	6	8 (out)								
Report flow from TP18 and TP7 to USRO Supervisor to assess whether additional monitoring is required.										
Notes:	(1): Pipe sizes and approximate flow directions are based on FMSS asset data along with SSMP Figure 4.5. (2): Flow measurement periods to include weekend flows. Recommended minimum 5 days of flow measurements to include 3 week days and 2 weekend days. Additional week day flow measurements should be collected if schedule allows									

TABLE 8.5 – C
Observed and Measured Sewer Flow Data for
Old El Portal Sewer System – Basin 6

Manhole Number	Pipe Diameter (inches)	Flow Direction ¹ (clock location of inlets and outlet)	Flow Measurement Period ²		Maximum Sewer Depth (inches or percent diameter)	Maximum Daily Flow		Minimum Daily Flow		Observations (e.g. date of presence of solids, sediments, foreign materials, roots, strong odors, water clarity)
			Start Date	Ending Date		(gpm)	(gpd)	(gpm)	(gpd)	
EP33	6	2 (in)								
EP33	16	8 (out)								
Action: If infiltration or 2/3 depth flow observed, proceed to EP30 for additional flow measurements.										
EP30	6	2 (in)								
EP30	4	1 (in)								
EP30	6	8 (out)								
Action: Report flow from EP30 to USRO Supervisor to assess whether additional monitoring is required.										
Notes:	(1): Pipe sizes and approximate flow directions are based on FMSS asset and 2009 CCTV data along with SSMP Figures 4.7 through 4.8. (2): Flow measurement periods to include weekend flows. Recommended minimum 5 days of flow measurements to include 3 week days and 2 weekend days. Additional week day flow measurements should be collected if schedule allows.									

TABLE 8.5 – D
Observed and Measured Sewer Flow Data for
Old El Portal Sewer System & Yosemite View Lodge – Basins 7 & 8

Manhole Number	Pipe Diameter (inches)	Flow Direction ¹ (clock location of inlets and outlet)	Flow Measurement Period ²		Maximum Sewer Depth (inches or percent diameter)	Maximum Daily Flow		Minimum Daily Flow		Observations (e.g. date of presence of solids, sediments, foreign materials, roots, strong odors, water clarity)
			Start Date	Ending Date		(gpm)	(gpd)	(gpm)	(gpd)	
EP49	6	1 (in)								
EP49	6	5 (out)								
Action: If infiltration or 2/3 depth flow observed, proceed to EP48 for additional flow measurements.										
EP48	6	2 (in)								
EP48	4	8 (in)								
EP48	4	11 (in)								
EP30	6	7 (out)								
Action: Report flow from EP48 to USRO Supervisor to assess whether additional monitoring is required.										
Yosemite View Lodge										
MH48	16	2 (in)								
MH48	6	4 (in)								
MH48	16	8 (out)								
Action: Report flow from MH48 to USRO Supervisor.										
Notes:	(1): Pipe sizes and approximate flow directions are based on FMSS asset and 2009 CCTV data along with SSMP Figures 4.7 through 4.9. (2): Flow measurement periods to include weekend flows. Recommended minimum 5 days of flow measurements to include 3 week days and 2 weekend days. Additional week day flow measurements should be collected if schedule allows.									

**TABLE 8.5 – E
Typical Template for Observation and Measured Sewer Flow Data**

Manhole Number	Pipe Diameter (inches)	Flow Direction ¹ (clock location of inlets and outlet)	Flow Measurement Period ²		Maximum Sewer Depth (inches or percent diameter)	Maximum Daily Flow		Minimum Daily Flow		Observations (e.g. date of presence of solids, sediments, foreign materials, roots, strong odors, water clarity)
			Start Date	Ending Date		(gpm)	(gpd)	(gpm)	(gpd)	
Action: Discuss results with USRO Supervisor to determine whether additional flow measurements are required.										
Notes:	(1): Pipe sizes and approximate flow directions are based on 2009 CCTV data and SSMP Figures 4.1 through 4.9. (2): Flow measurement periods to include weekend flows. Recommended minimum 5 days of flow measurements to include 3 week days and 2 weekend days. Additional week day flow measurements should be collected if schedule allows.									

**TABLE 8.6
Summary of Sewer Flow Measurements**

Item No.	Manhole or Cleanout (clock location of pipe segment measured)	Instrument Measured Flow		Calculated Flow		Estimated I & I (Percent of Flow or gpm)	Requires Sewer Enhancement Project ¹ (YES or NO)	Observations and Remarks (Prepare and Report Class C Cost Estimates)
		Maximum Depth (inches or percent pipe diameter)	Maximum Weekly Velocity (fps)	Average Daily (gpm)	Weekly Maximum (gpd)			
Note:	(1): All sewer segments requiring sewer enhancement or rehabilitation and/or repair should be reported to the USRO supervisors and be documented in the Facility Management Software System.							

YOSEMITE NATIONAL PARK UTILITIES BRANCH

SEWER SYSTEM MANAGEMENT PLAN EL PORTAL SANITARY SEWER SYSTEM (CS 5SSO10735)

This page left intentionally blank.

YOSEMITE NATIONAL PARK UTILITIES BRANCH

SEWER SYSTEM MANAGEMENT PLAN EL PORTAL SANITARY SEWER SYSTEM (CS 5SSO10735)

9.0 MONITORING, MEASUREMENT AND PROGRAM MODIFICATIONS

YOSEMITE NATIONAL PARK UTILITIES BRANCH

SEWER SYSTEM MANAGEMENT PLAN

EL PORTAL

SANITARY SEWER SYSTEM (CS 5SSO10735)

9.1 REGULATORY REQUIREMENTS FOR THE MONITORING, MEASUREMENT AND PROGRAM MODIFICATIONS ELEMENT

This Monitoring, Measurement, and Program Modifications Element describes the National Park Service (NPS) program for Yosemite National Park (YNP) to assess and evaluate the monitoring and measurement of SSMP activities in order to implement modifications to the program as needed for compliance with the condition of the California State Water Resources Control Board (SWRCB) Order No. 2006-0003, Statewide General Discharge Requirements for Sanitary Sewer Systems. Board Order No. 2006-0003 requires sanitary sewer systems to develop and implement sewer system management plans (SSMPs) to include Monitoring, Measurement, and Program Modifications. Furthermore, Board Order No. 2006-0003 details the content requirements for Monitoring, Measurement, and Program Modifications and should include:

- (a) Maintain relevant information that can be used to establish and prioritize appropriate SSMP activities;
- (b) Monitor the implementation and, where appropriate, measure the effectiveness of each element of the SSMP;
- (c) Assess the success of the preventative maintenance program;
- (d) Update program elements, as appropriate, based on monitoring or performance evaluations; and
- (e) Identify and illustrate SSO trends, including: frequency, location, and volume.

Adoption of Amended Monitoring and Reporting Requirements under SWRCB Order No. WQ 2008-0002-EXEC for Statewide General Waste Discharge Requirements for Sanitary Sewer Systems (as of February 20, 2008), include:

1. For any discharges of sewage that result in a discharge to a drainage channel or a surface water, the Discharger shall, as soon as possible, but no later than two (2) hours after becoming aware of the discharge, notify the State Office of Emergency Services, the local health officer or directors of environmental health with jurisdiction over affected water bodies, and the appropriate Regional Water Quality Control Board.

YOSEMITE NATIONAL PARK UTILITIES BRANCH

SEWER SYSTEM MANAGEMENT PLAN

EL PORTAL

SANITARY SEWER SYSTEM (CS 5SSO10735)

2. As soon as possible, but no later than twenty-four (24) hours after becoming aware of a discharge to a drainage channel or a surface water, the Discharger shall submit to the appropriate Regional Water Quality Control Board a certification that the State Office of Emergency Services and the local health officer or directors of environmental health with jurisdiction over the affected water bodies have been notified of the discharge.

The NPS will monitor the effectiveness of the El Portal SSMP on a regular basis, and will update and modify the El Portal SSMP elements to keep them current, accurate, and available for audit including the reporting requirements under SWRCB Order No. WQ 2008-0002-EXEC. The following section describes the NPS's procedure for monitoring the effectiveness of the El Portal SSMP and the procedures used to prevent SSOs.

9.2 PERFORMANCE MEASURES

Through the use of Performance Indicators (PI) Utilities Management staff will track information obtained through sewer cleaning logs and regularly prepared reports and inspections to include: CCTV pipeline inspection reports, manhole inspection reports, SSO reports, etc. USRO staff in El Portal will follow a procedure whereby specific parameters are documented and compared on an annual basis to monitor the effectiveness of the El Portal SSMP. These parameters will provide quantitative information that indicates the measure of success of the El Portal SSMP or areas of underlying problems that may then be further investigated. Table 9.1 provides a list of SSMP elements, the overall purpose of each SSMP element, and specific parameters that USRO staff will track to help with evaluating the effectiveness of the El Portal SSMP.

YOSEMITE NATIONAL PARK UTILITIES BRANCH

SEWER SYSTEM MANAGEMENT PLAN

EL PORTAL

SANITARY SEWER SYSTEM (CS 5SSO10735)

TABLE 9.1
SSMP Elements – Monitoring Parameters

SSMP Element	Summary of Element Purpose	Performance Indicator
1.0 - Goals	Establish priorities within goals and provide focus for USRO Staff	As part of Element 10 – Program Audits, reconsider Goals and evaluate potential changes
2.0 - Organization	Document organization of USRO staff and chain of communication for SSO response	As part of Element 10 – Program Audits, update Organization Chart as staff changes or reorganizations occur.
3.0 - Legal Authority	Ensure the NPS has sufficient legal authority to properly maintain the system	None needed
4.0 - Operations and Maintenance Plan	Minimize blockages and eliminate SSOs by properly maintaining the system and keeping the system in good condition	<ul style="list-style-type: none"> • Total number and volume of SSOs • Causes of SSOs • Number of repeat SSOs (same location as any previous SSO, regardless of year of occurrence) • Length of pipe inspected with CCTV per year
5.0 - Design and Construction Standards	Ensure new facilities and capital improvement projects are properly designed and constructed	None needed
6.0 - Overflow Emergency Response	Provide timely and effective response to SSO emergencies and comply with regulatory reporting requirements	<ul style="list-style-type: none"> • Average and maximum response time • Percent of total overflow volume contained or returned to sewer • Met Regulatory Reporting Schedules in Section 8.

YOSEMITE NATIONAL PARK UTILITIES BRANCH

SEWER SYSTEM MANAGEMENT PLAN

EL PORTAL

SANITARY SEWER SYSTEM (CS 5SSO10735)

**TABLE 9.1 (Continued)
SSMP Elements – Monitoring Parameters**

SSMP Element	Summary of Element Purpose	Performance Indicator
7.0 - Fats, Oil, and Grease Control	Minimize blockages and eliminate overflows due to FOG	<ul style="list-style-type: none"> • Number of overflows due to FOG (linked to SSO Identification Number) • Number of FOG producing facilities inspected (on schedule) • Percent of FOG producing facilities found to be in compliance
8.0 - Capacity Management	Eliminate SSOs due to insufficient capacity by evaluating the system capacity and implementing necessary capital improvement projects	Number of SSOs due to capacity limitations or wet weather (linked to SSO Identification Number)
9.0 - Monitoring, Measurement, and Program Modifications	Evaluate effectiveness of SSMP, keep SSMP up-to-date, and identify necessary changes	As part of Element 10 – Program Audits, evaluate tracking of Performance Indicator and effectiveness in determining effectiveness of SSMP
10.0 - Program Audits	Formally identify SSMP effectiveness, limitations, and necessary changes on an annual basis	Date of completion of last annual audit
11.0 – Communication Plan	Communicate with the public, concessionaires under contract and satellite agencies	<ul style="list-style-type: none"> • Number of written and verbal comments received from the public and concessionaires. • Percentage of positive comments.
12.0 - Certification	To provide confirmation of SSMP SSO response reporting for compliance with SSMP program.	<ul style="list-style-type: none"> • Internal audits and State inspections performed under State Order No. 2006 – 0003 Section F.

YOSEMITE NATIONAL PARK UTILITIES BRANCH

SEWER SYSTEM MANAGEMENT PLAN EL PORTAL SANITARY SEWER SYSTEM (CS 5SSO10735)

USRO staff will use PI's to assist with completion of the annual El Portal SSMP program audit described in Section 10. Utilities Management staff will also track additional information, including input from concessionaires regarding maintenance records to include length of pipe cleaned, to assist with evaluation of the SSMP effectiveness.

The indicators that the NPS will use to measure the performance of its wastewater collection system and the effectiveness of its SSMP are found in Table 9.2, Performance Indicator Checklist in Section 9.3.

9.3 HISTORICAL PERFORMANCE DATA

El Portal sewer system has limited historical performance data at this time. USRO staff has been reporting SSOs using California Integrated Water Quality System (CIWQS) since September 2, 2007 and has been tracking SSO events prior to CIWQS reporting. USRO staff will track parameters given in Table 9.1, the result of which will be included in the PI checklist in Table 9.2. The El Portal SSMP will be updated periodically to maintain current information. USRO site supervisor will review the success of and/or necessary improvements to the El Portal SSMP as part of an annual SSMP program audit (described in Section 10). USRO site supervisor will also update important information, such as contact numbers and USRO staff changes as needed. A comprehensive SSMP update should occur every five years.

YOSEMITE NATIONAL PARK UTILITIES BRANCH

SEWER SYSTEM MANAGEMENT PLAN

EL PORTAL

SANITARY SEWER SYSTEM (CS 5SSO10735)

TABLE 9.2
Performance Indicator Checklist

Performance Indicator	2013	2014	2015	2016	2017
Total number of SSOs					
Met required SSO reporting schedule requirements (see Section 6)					
Total volume of SSOs					
Median volume of SSO (gallons)					
Number of repeat SSOs (same location as any previous SSO, regardless of year of occurrence)					
Percentage of total sewer overflow volume contained of total sewer overflow volume spilled					
Percentage of sewer overflow volume recovered and returned to sewer system to total sewer overflow volume spilled					
Percentage of total sewage spilled entering surface waters.					
Percentage of SSOs reported as Category 1.					
SSO Rate (Number of SSOs/1 mile/year)					
SSO Volume Rate (SSOs Volume/1 mile/year)					
Number of SSOs due to pump station failures					
Number of SSOs due to pipe failures					
Number of SSOs due to roots					
Number of SSOs due to debris					
Number of SSOs due to other					

YOSEMITE NATIONAL PARK UTILITIES BRANCH

SEWER SYSTEM MANAGEMENT PLAN EL PORTAL SANITARY SEWER SYSTEM (CS 5SSO10735)

**TABLE 9.2 (Continued)
Performance Indicator Checklist**

Performance Indicator	2013	2014	2015	2016	2017
Length of pipe CCTV'd (miles)					
Number of overflows due to FOG					
Number of FOG producing facilities inspected					
Percent of FOG producing facilities found to be in compliance					
Number of SSOs due to capacity limitations or wet weather					

9.4 BASELINE PERFORMANCE

The baseline performance, which shows the performance of the El Portal wastewater collection prior to the implementation of the SSMP over the last five years, is shown on Table 9.3. Analysis will be conducted in the future as additional data becomes available.

YOSEMITE NATIONAL PARK UTILITIES BRANCH

SEWER SYSTEM MANAGEMENT PLAN

EL PORTAL

SANITARY SEWER SYSTEM (CS 5SSO10735)

TABLE 9.3
Baseline Performance of SSO Data for El Portal (2008 to 2013)
(Data Source – NPS)

Performance Indicator			
Primary Cause of SSOs	Total Volume of SSOs (gallons)	Number of SSOs	Percent of SSOs
Roots	1200	3	50%
Grease	30	1	16.66%
Debris	-	0	0%
Pipe Failures	-	0	0%
Lift Station Failure	20	1	16.66%
Line Blockage	75	1	16.66%
Other	-	0	0%

There are approximately 4.1 miles of sewer piping in the El Portal collection system; therefore six SSOs in the last five years is equivalent to 0.29 SSO/mile/year. In addition to the Baseline Performance data El Portal experienced five SSO events in 2005.

9.5 PERFORMANCE MONITORING AND PROGRAM CHANGES

The USRO site supervisor will evaluate the performance of the El Portal wastewater collection system at least annually using the performance measures identified in Section 9.2 and the Performance Indicator Checklist presented in Section 9.3. USRO staff will update the data and analysis of performance measures at the time of the evaluation. USRO staff may use other performance measures in its evaluation.

YOSEMITE NATIONAL PARK UTILITIES BRANCH

SEWER SYSTEM MANAGEMENT PLAN EL PORTAL SANITARY SEWER SYSTEM (CS 5SSO10735)

9.6 SSMP UPDATES

USRO staff will update EI Portal SSMP at least every five years. The first update will be completed in 2017. USRO staff will determine the need to update EI Portal SSMP more frequently based on the results of the bi-annual audit and the performance of its sanitary sewer system. In the event that the YNP decides that an update is warranted, the process to complete the update will be identified at that time. USRO staff will complete the update within one year following identification of the need for the update. The authority for approval of minor changes such as employee names, contact information, or minor procedural changes exists within YNP. USRO staff will certify that it has completed the bi-annual audit using CIWQS. Copies of the current EI Portal SSMP document will be available during normal business hours to all interested parties at the Utilities Branch of the Division of Facilities Management.

YOSEMITE NATIONAL PARK UTILITIES BRANCH

SEWER SYSTEM MANAGEMENT PLAN EL PORTAL SANITARY SEWER SYSTEM (CS 5SSO10735)

10.0 SSMP PROGRAM AUDIT

YOSEMITE NATIONAL PARK UTILITIES BRANCH

SEWER SYSTEM MANAGEMENT PLAN

EL PORTAL

SANITARY SEWER SYSTEM (CS 5SSO10735)

10.1 REGULATORY REQUIREMENTS

The National Park Service (NPS) has developed a comprehensive Sewer System Management Plan (SSMP) for the Yosemite National Park (YNP) that fully adheres to the requirements stipulated in State Water Resource Control Board (SWRCB) Order No. 2006-0003. SWRCB Order No. 2006-0003 requires facilities as part of the SSMP to conduct periodic internal audits, appropriate to the size of the system and the number of SSOs. At a minimum, the audits must occur every two years and a report must be prepared and kept on file. The audits will focus on evaluating the effectiveness of the SSMP to prevent SSOs as well as subsequent SSO response actions to include notification and reporting SSOs to regulators as stipulated in SWRCB Order No. 2006-0003. Additionally, the audit should identify SSMP deficiencies and the appropriate steps necessary to correct any SSMP deficiency.

10.2 SSMP AUDITS

The NPS will audit its SSMP for the YNP every two years. The SSMP audit will help determine whether the SSMP meets the current requirements of applicable SWRCB Orders, whether the SSMP reflects current NPS practices, and whether the NPS is correctly implementing the SSMP. The first SSMP audit should be completed by October 1, 2014 and thereafter SSMP audits should be performed every two years with a final report completed by January 1st of each odd numbered year.

The audit should be conducted by a team consisting of at least the Facility Manager or designee of the Utilities Branch and the Branch Chief or designee from the Design and Engineering Branch of the Facilities Management Division.

The scope of the audit will review each of the twelve sections of the SSMP and closely follow the SSMP Audit Checklist, based on the requirements stipulated in SWRCB Order No. 2006-0003. Records and information kept by the Utilities Branch and Design and Engineering Branch should be reviewed and the Utility System Repairer and Operator (USRO) field staff and USRO supervisors should be interviewed to ascertain apparent SSMP program implementation problems.

YOSEMITE NATIONAL PARK UTILITIES BRANCH

SEWER SYSTEM MANAGEMENT PLAN EL PORTAL SANITARY SEWER SYSTEM (CS 5SSO10735)

The results of the audit will be presented in an SSMP Audit Report that will summarize the:

1. Effectiveness of the SSMP program to uncover potential sewer collection system deficiencies that may create sewer system overflow (SSO),
2. Effectiveness of the SSMP program to timely implement sewer collection system improvements to prevent SSOs,
3. Capability to provide timely SSO response, notification, and reporting in accordance with SWRCB Order No. 2006-0003, and
4. Identification of SSMP program deficiencies and revisions necessary to make SSMP program more effective.

The Facilities Manager or designee of the Utilities Branch will ensure all audit findings are incorporated and the SSMP revised. The SSMP Audit Checklist is presented in Exhibit 10.1.

The Superintendent or delegated authority must certify that it has completed the bi-annual audit report to the Central Valley Regional Water Quality Board by using the online SSO reporting system with the California Integrated Water Quality System (CIWQS). Completed copies of the bi-annual Audit Report must be retained for five years.

YOSEMITE NATIONAL PARK UTILITIES BRANCH

SEWER SYSTEM MANAGEMENT PLAN

EL PORTAL

SANITARY SEWER SYSTEM (CS 5SSO10735)

EXHIBIT 10.1 SSMP Audit Checklist

Section No.	Audit Requirement	Meets SSMP Criteria (yes/no)	Remarks and SSMP Revision Recommendations
1	Goals		
	a. Are goals to reduce, prevent, and mitigate SSOs still appropriate?		
2	Organization		
	<p>a. Are Yosemite National Park (YNP) organization and Branch staffing contacts current?</p> <p>Describe changes:</p> <ul style="list-style-type: none"> • Utilities Branch • Design and Engineering Branch <p>b. Are agency organization and contacts current?</p> <p>Describe changes:</p> <ul style="list-style-type: none"> • Central Valley Regional Water Quality Board • Mariposa County Health Department/ or Tuolumne County for other systems • State Office of Emergency Services 		
3	Legal Authority		
	<p>Describe any problems experienced with legal authority since last audit and does YNP appear to have sufficient authority to:</p> <p>a. control sewer construction design and construction for sewer repairs, sewer rehabilitation, and new sewers?</p> <p>b. prevent illicit sewer discharges such as inflow?</p>		

YOSEMITE NATIONAL PARK UTILITIES BRANCH

SEWER SYSTEM MANAGEMENT PLAN

EL PORTAL

SANITARY SEWER SYSTEM (CS 5SSO10735)

EXHIBIT 10.1 (Continued) SSMP Audit Checklist

Section No.	Audit Requirement	Meets SSMP Criteria (yes/no)	Remarks and SSMP Revision Recommendations
3	Legal Authority		
	<ul style="list-style-type: none"> c. prevent or limit sewer discharge of fats, oils, and greases (FOG)? d. inspect FOG producing facilities? e. require the installation of grease removal devices as necessary? f. provide resources for safe worker access for inspection, maintenance, and repairs? 		
4	Operation and Maintenance Program		
	<ul style="list-style-type: none"> a. Is the mapping of the sewer collection system current? Describe changes since last audit. b. Is the description of the sewer collection system current? Describe changes since last audit. c. Is the Facility Management Software System (FMSS) help desk being effectively utilized? Describe any problems. d. Have sewer cleaning and/or inspection activities for sewer manholes, sewer piping, lift stations, force mains, and oil/water separators been timely completed since the last audit? Describe problems. e. Is the equipment and replacement parts inventory current? Describe changes. 		

YOSEMITE NATIONAL PARK UTILITIES BRANCH

SEWER SYSTEM MANAGEMENT PLAN

EL PORTAL

SANITARY SEWER SYSTEM (CS 5SSO10735)

EXHIBIT 10.1 (Continued) SSMP Audit Checklist

Section No.	Audit Requirement	Meets SSMP Criteria (yes/no)	Remarks and SSMP Revision Recommendations
4	Operation and Maintenance Program		
	<p>f. Are USRO staff appropriately trained with recommended certifications? Describe courses since last audit.</p> <p>g. Is the rehabilitation and replacement plan being effectively utilized to identify and prioritize sewer system improvements? Summarize all Priority 1 sewer system improvements and their scheduled start and completion dates.</p> <p>h. Has a capital improvement plan been prepared within one year of this audit? Attach most recent plan to this audit.</p>		
5	Design and Performance Provisions		
	<p>a. Are the design and construction standards for new sanitary sewer system facilities current? Describe changes since last audit and date when the standards were last updated.</p> <p>b. Are the design and construction standards for sewer repair and rehabilitation of existing sewer systems current? Describe changes since last audit and date when the standards were last updated.</p> <p>c. Are the procedures for construction inspection and acceptance current? Describe changes since last audit.</p>		

YOSEMITE NATIONAL PARK UTILITIES BRANCH

SEWER SYSTEM MANAGEMENT PLAN

EL PORTAL

SANITARY SEWER SYSTEM (CS 5SSO10735)

EXHIBIT 10.1 (Continued) SSMP Audit Checklist

Section No.	Audit Requirement	Meets SSMP Criteria (yes/no)	Remarks and SSMP Revision Recommendations
6	SSO – Overflow Emergency Response Plan		
	<p>a. Has the California-specific sewer system overflow (SSO) notification and reporting requirements remained the same since the last audit? Report new SWRCB Order No. and describe changes to SSO notification and reporting requirements since last audit.</p> <p>b. Have the internal YNP SSO reporting requirements remained the same for Utilities staff since the last audit? Describe changes.</p> <p>c. Does the site maintain records for each SSO notification and reporting event to include environmental sampling results?</p> <p>d. Review SSO statistics summary for the preceding five years. See Section 9 below.</p>		
7	FOG Control Program		
	<p>a. Has the FOG control program effectively prevented SSOs since the last audit? Any SSOs caused by FOG reflects an ineffective program.</p> <p>b. List or map FOG problem areas uncovered since last audit.</p> <p>c. Describe the facilities having FOG control program issues, when inspected, and their respective inspection findings.</p>		

YOSEMITE NATIONAL PARK UTILITIES BRANCH

SEWER SYSTEM MANAGEMENT PLAN

EL PORTAL

SANITARY SEWER SYSTEM (CS 5SSO10735)

EXHIBIT 10.1 (Continued) SSMP Audit Checklist

Section No.	Audit Requirement	Meets SSMP Criteria (yes/no)	Remarks and SSMP Revision Recommendations
7	FOG Control Program		
	d. Has the public outreach program to promote the proper handling and disposal of FOG been implemented? Describe.		
8	System Evaluation and Capacity Assurance Plan		
	<p>a. Has the Utilities and Engineering staff actively assessed sewer hydraulic capacity since the last audit? Describe.</p> <p>b. Are the procedures and design criteria adequate for determining sewer hydraulic capacities?</p> <p>c. Data and information collected since the last audit does not indicate any pipe segments or manholes are limited in sewer hydraulic capacity.</p> <p>d. Are the sewer flow measuring equipment and data logger properly maintained, operational, and calibrated? Describe.</p> <p>e. Describe any sewer enhancement projects identified and constructed since the last audit.</p>		
9	Monitoring, Measurement, and Program Modifications		
	<p>a. Are relevant records and logs maintained to demonstrate SSMP implementation?</p> <p>b. Is Performance Indicator Checklist current as presented in Table 9.2 in the SSMP? Attach Table 9.2 to audit report.</p>		

YOSEMITE NATIONAL PARK UTILITIES BRANCH

SEWER SYSTEM MANAGEMENT PLAN

EL PORTAL

SANITARY SEWER SYSTEM (CS 5SSO10735)

EXHIBIT 10.1 (Continued) SSMP Audit Checklist

Section No.	Audit Requirement	Meets SSMP Criteria (yes/no)	Remarks and SSMP Revision Recommendations
9	Monitoring, Measurement, and Program Modifications		
	c. Has the SSMP been updated, partly based on SSMP monitoring or performance?		
10	SSMP Program Audits		
	a. Are SSMP program audits performed bi-annually? b. Were appropriate corrective actions taken for the negative findings or deficiencies noted in the previous bi-annual audit report?		
11	Communication Program		
	a. Are the SSMP problems encountered and their respective solutions communicated with the other YNP areas? (i.e., Hodgdon Meadow, Tuolumne Meadows, Wawona, White Wolf, and Yosemite Valley) Describe. b. Is the performance of the SSMP communicated with the public? Describe.		
12	Certification of Compliance		
	a. Is SSMP SSO response reporting content and scheduling criteria satisfied?		

YOSEMITE NATIONAL PARK UTILITIES BRANCH

SEWER SYSTEM MANAGEMENT PLAN EL PORTAL SANITARY SEWER SYSTEM (CS 5SSO10735)

Attachment Per Section 9-b of Exhibit 10.1

TABLE 9.2
Performance Indicator Checklist

PERFORMANCE INDICATOR	2013	2014	2015	2016	2017
Total number of SSOs					
Met required SSO reporting schedule requirements (see Section 6)					
Total volume of SSOs					
Median volume of SSO (gallons)					
Number of repeat SSOs (same location as any previous SSO, regardless of year of occurrence)					
Percentage of total sewer overflow volume contained of total sewer overflow volume spilled					
Percentage of sewer overflow volume recovered and returned to sewer system to total sewer overflow volume spilled					
Percentage of total sewage spilled entering surface waters					
Percentage of SSOs reported as Category 1					
SSO Rate (number of SSOs / 1 mile / year)					
SSO Volume Rate (SSOs volume / 1 mile / year)					
Number of SSOs due to pump station failures					

YOSEMITE NATIONAL PARK UTILITIES BRANCH

SEWER SYSTEM MANAGEMENT PLAN EL PORTAL SANITARY SEWER SYSTEM (CS 5SSO10735)

Attachment Per Section 9-b of Exhibit 10.1

**TABLE 9.2 (Continued)
Performance Indicator Checklist**

PERFORMANCE INDICATOR	2013	2014	2015	2016	2017
Number of SSOs due to pipe failures					
Number of SSOs due to roots					
Number of SSOs due to debris					
Number of SSOs due to other					
Length of pipe CCTV'd (miles)					
Number of overflows due to FOG					
Number of FOG producing facilities inspected					
Percent of FOG producing facilities found to be in compliance					
Number of SSOs due to capacity limitations or wet weather					

YOSEMITE NATIONAL PARK UTILITIES BRANCH

SEWER SYSTEM MANAGEMENT PLAN EL PORTAL SANITARY SEWER SYSTEM (CS 5SSO10735)

This page left intentionally blank.

YOSEMITE NATIONAL PARK UTILITIES BRANCH

SEWER SYSTEM MANAGEMENT PLAN EL PORTAL SANITARY SEWER SYSTEM (CS 5SSO10735)

11.0 COMMUNICATION PROGRAM

YOSEMITE NATIONAL PARK UTILITIES BRANCH

SEWER SYSTEM MANAGEMENT PLAN

EL PORTAL

SANITARY SEWER SYSTEM (CS 5SSO10735)

11.1 REGULATORY REQUIREMENT

The National Park Service (NPS) has developed a comprehensive Sewer System Management Plan (SSMP) for the Yosemite National Park (YNP) that closely adheres to the requirements stipulated in State Water Resource Control Board (SWRCB) Order No. 2006-0003. SWRCB Order No. 2006-0003 requires facilities as part of the SSMP to develop and implement a communication program which details a process for communicating and soliciting public input as to the development, implementation, and performance of the SSMP.

11.2 COMMUNICATING DEVELOPMENT AND IMPLEMENTATION

SSMP development and implementation should consider public input from potential El Portal stakeholders that include: concessionaires, businesses, governmental agencies, residents, and other individuals that may be subject to the requirements of the SSMP. The El Portal sewer collection system does not have any tributary/satellite sewer systems that would otherwise need direct notification. The draft SSMP should be available for public viewing for 30 calendar days prior to final SSMP completion and certification compliance or approval that is issued by the Park Superintendent or his designee. Soliciting public input to the SSMP is a function of the Utilities Facilities Manager or designee that will require notices to be sent to all YNP licensed/contracted concessionaires and businesses, governmental agencies, and to known local residents that are serviced by the El Portal sewer collection system. Though licensed concessionaires and businesses as well as other governmental agencies should be contacted by mailings, other methods such as local site postings, newspaper articles, and flyers may be used to notify stakeholders of the location and time for accessing copies of the SSMP and the ending date for receipt of SSMP comments. A listing of those contacted and their respective contact information should be developed and maintained by the Facilities Manager for subsequent correspondences and notifications. Electronic news mailings and the Park's web page may be used as appropriate. The NPS will provide responses to public comments and/or specifically meet with public who have comments to ensure the public input is appropriately and accurately incorporated into the final SSMP.

YOSEMITE NATIONAL PARK UTILITIES BRANCH

SEWER SYSTEM MANAGEMENT PLAN EL PORTAL SANITARY SEWER SYSTEM (CS 5SSO10735)

The following schedule in Table 11.1 outlines the schedule for SSMP development and implementation.

TABLE 11.1
SSMP Development and Implementation Schedule

Description of SSMP Schedule for Development and Implementation	Completion Date
NPS contractor completes SSMP (draft) with NPS input	June 2013
NPS solicits public input	July 2013
NPS completes final SSMP with public input	October 2013
NPS implements SSMP and submits SSMP certification of compliance to the CIWQS	November 2013
CIWQS: California Integrated Water Quality System	

11.3 COMMUNICATING SEWER SYSTEM PERFORMANCE

All SSOs are electronically reported by the Facilities Manager or designee to the California Integrated Water Quality System (CIWQS) for regulatory reporting and recordkeeping in accordance with Section 6 of this SSMP. SSOs and other sanitary sewer performance information for El Portal are available at the CIWQS public access website: <http://www.waterboards.ca.gov/ciwqs/publicreports.shtml#sso>. SSOs and other sanitary sewer performance information that may affect the public will require subsequent public notifications, using the public notification system described in Section 11.1, but the public should also receive a yearly or bi-yearly update of the sewer system performance. Yearly updates are required if more than one SSO has occurred and/or if there is other significant sewer system performance data that needs to be conveyed to stakeholders, otherwise, bi-yearly updates are appropriate. The yearly or bi-yearly updates are intended to ensure the YNP community is aware of the sewer system

YOSEMITE NATIONAL PARK UTILITIES BRANCH

SEWER SYSTEM MANAGEMENT PLAN

EL PORTAL

SANITARY SEWER SYSTEM (CS 5SSO10735)

improvements since the previous update report, impacts and responses associated with previous SSOs, and any changes or revisions to the SSMP that will affect the responsibilities or procedures associated with sewer system management that includes emergency response actions and the proper management and disposal of cooking fats, oils, and greases (FOG).

Note this Communication Program is included in the SSMP Audit Checklist, presented in Exhibit 10.1.

11.4 EDUCATIONAL INFORMATION

The NPS will continue to conduct public outreach and education for businesses and residents affected by SSOs following SSMP implementation. The NPS will employ the public notification program discussed in Section 11.2 to disseminate information to stakeholders regarding the need and methods to reduce SSOs. Stakeholders shall have access to educational information regarding the prevention and reporting of SSOs and the results of previous audits. The Utilities Branch Management Office in El Portal will keep this information on record for public viewing.

YOSEMITE NATIONAL PARK UTILITIES BRANCH

SEWER SYSTEM MANAGEMENT PLAN EL PORTAL SANITARY SEWER SYSTEM (CS 5SSO10735)

12.0 CERTIFICATION OF COMPLIANCE

This section of the SSMP covers certification of compliance for the El Portal wastewater collection system.

YOSEMITE NATIONAL PARK UTILITIES BRANCH

SEWER SYSTEM MANAGEMENT PLAN EL PORTAL SANITARY SEWER SYSTEM (CS 5SSO10735)

12.1 REGULATORY REQUIREMENTS FOR CERTIFICATION OF COMPLIANCE

The National Park Service (NPS) owns and operates the sanitary sewer system serving El Portal Community and must comply with the provisions contained in California Water Code and the State Water Resource Control Board (SWRCB) Order No. 2006-0003 that requires the development and implementation of Sewer System Management Plans (SSMPs) to prevent sanitary sewer overflows (SSOs) and to minimize their subsequent environmental impacts. The Board Order No 2006-0003 stipulates that the SSMP must be initially certified and updated every five years to include any significant program changes, whereas “*SSMP certification by technically qualified and experienced persons can provide a useful and cost-effective means for ensuring SSMPs are developed and implemented appropriately.*”

The Yosemite National Park Superintendent has been designated to certify the SSMP and all subsequent reporting requirements associated with the SSMP.

The Utilities Branch has set up an SSO database account with the California Integrated Water Quality System (CIWQS) and will maintain the database account as well as retain all records of all SSOs such as, but not limited to and when applicable:

- a. Record of Certified report, as submitted to the online SSO database;
- b. All original recordings for continuous monitoring instrumentation;
- c. Service call records and complaint logs of calls received;
- d. SSO calls;
- e. SSO records;
- f. Steps that have been and will be taken to prevent the SSO from recurring and a schedule to implement those steps.
- g. Work orders, work completed, and any other maintenance records from the previous 5 years which are associated with responses and investigations of system problems related to SSOs;
- h. A list and description of complaints from customers or others from the previous 5 years; and
- i. Documentation of performance and implementation measures for the previous 5 years.

YOSEMITE NATIONAL PARK UTILITIES BRANCH

SEWER SYSTEM MANAGEMENT PLAN

EL PORTAL

SANITARY SEWER SYSTEM (CS 5SSO10735)

The initial SSMP certification process begins with completing and signing the automated forms referred to in the Online SSO Database Questionnaire using CIWQS and submitting hardcopies to the State Water Resources Control Board, Division of Water Quality, Attn: SSO Program Manager, PO Box 100, Sacramento, California 95812.

A draft SSMP is prepared and is available for public viewing for 30 calendar days before the final SSMP is completed, approved, and certified by the Park Superintendent using CIWQS automated form presented as Figure 12.1 at the end of this section.

Thereafter, SSMP implementation requires SSO response reporting as described in Section 6 of the SSMP that also requires report certification by the Park Superintendent prior to report submittal. Potential SSO response reports include:

1. Certifications within 24 hours of spills affecting water bodies that the State Office of Emergency Services and the local health officer or directors of environmental health with jurisdiction over the affected water bodies have been notified of the discharge.
2. Initial Category 1 SSO reports no later than 3 business days following a spill.
3. Final Category 1 SSO reports within 15 calendar days of the spill.
4. All Category 2 SSOs reports within 30 days after the end of the calendar month in which the SSO occurs,
5. Monthly statement reports certifying that there were no SSOs for the designated month.
6. Annual completion and certification of the Collection System Questionnaire.

Updates to any previous spill report can be submitted at any time thereafter; however, the updated report must be certified by the Park Superintendent.

Additionally, the Park Superintendent is required to certify California Waste Discharge Requirement reports (WDRs) for each wastewater facility i.e. El Portal and Wawona.

It should be understood that the general public has access to SSO reporting data to include site specific spill description information and data; therefore, timely and accurate reporting is crucial to reflect a responsive and responsible owner and operator of a sanitary sewer system.

FIGURE 12.1



[Menu](#) | [Help](#) | [Log out](#)

Navigate to:

You are logged-in as: dneubacher . If this account does not belong to you, please log out.

SSO - Sewer System Management Plan (SSMP) ? [SSO Menu](#)

Regional Water Board:	Region 5F - Fresno
Agency:	US Dept of the Interior
Sanitary Sewer System:	EI Portal CS
WDID:	5SSO10735

Last Updated:	2012-08-20 14:13:33.738764
----------------------	----------------------------

SSMP Element	Certification Date
Development Plan and Schedule	<input style="width: 80px;" type="text"/> (Date Format: MM/DD/YYYY)
Section I - Goal	<input style="width: 80px;" type="text" value="08/19/2010"/> (Date Format: MM/DD/YYYY)
Section II - Organization	<input style="width: 80px;" type="text" value="08/19/2010"/> (Date Format: MM/DD/YYYY)
Section III - Legal Authority	<input style="width: 80px;" type="text" value="08/19/2010"/> (Date Format: MM/DD/YYYY)
Section IV - Operation & Maintenance Program	<input style="width: 80px;" type="text"/> (Date Format: MM/DD/YYYY)
Section V - Design & Performance Provisions	<input style="width: 80px;" type="text"/> (Date Format: MM/DD/YYYY)
Section VI - Overflow Emergency Response Plan	<input style="width: 80px;" type="text" value="08/19/2010"/> (Date Format: MM/DD/YYYY)
Section VII - FOG Control Program	<input style="width: 80px;" type="text"/> (Date Format: MM/DD/YYYY)
Section VIII - System Evaluation & Capacity Assurance Plan	<input style="width: 80px;" type="text"/> (Date Format: MM/DD/YYYY)
Section IX - Monitoring, Measurement, and Program Modifications	<input style="width: 80px;" type="text"/> (Date Format: MM/DD/YYYY)
Section X - SSMP Program Audits	<input style="width: 80px;" type="text"/> (Date Format: MM/DD/YYYY)
Section XI - Communication Program	<input style="width: 80px;" type="text"/> (Date Format: MM/DD/YYYY)
Complete SSMP Implementation	<input style="width: 80px;" type="text"/> (Date Format: MM/DD/YYYY)

Note: 'Complete SSMP Implementation' is only available for input only if all its above sections filled.

Note: The Certification Note and Certified By fields disappear after certifying your SSMP. Previous entries can be seen on the Historic SSMP information screen.

Certification Note:	
5-Year Update	<input style="width: 80px;" type="text"/> (Date Format: MM/DD/YYYY)
* Certified by:	

Note: Questions with "*" are required to be answered before CERTIFY.

YOSEMITE NATIONAL PARK UTILITIES BRANCH

SEWER SYSTEM MANAGEMENT PLAN EL PORTAL SANITARY SEWER SYSTEM (CS 5SSO10735)

13.0 RATE ANALYSIS

YOSEMITE NATIONAL PARK UTILITIES BRANCH

SEWER SYSTEM MANAGEMENT PLAN

EL PORTAL

SANITARY SEWER SYSTEM (CS 5SSO10735)

13.1 DIRECTOR'S ORDER PURPOSE AND REQUIREMENTS

The National Park Service (NPS) has completed a comprehensive study of the costs associated with the operation and maintenance of the El Portal sewer collection system for the establishment of a user rate that closely adheres to the Director's Order No. 35B (DO 35B), "Cost Recovery for National Park Service Utilities".

The Director's Order purpose is to recover the operational, maintenance, and capital costs in order to *"bring NPS into alignment with Office of Management and Budget (OMB) guidance and better balance the NPS's need for more complete cost recovery when providing utilities, including annual operating costs, cyclical repair and rehabilitation costs, and capital investment cost, to non-NPS users."*

13.2 DETERMINATION OF RATE STRUCTURES

DO 35B allows the Park to select from three different types of rates structures when determining the most appropriate rate structure for recovering their utilities costs.

These three forms include:

1. Single Unit Rate
The simplest form of rate structure is the single unit rate structure. It is calculated by dividing the total costs by the total number of units of utility service produced. This calculation results in a uniform rate equal to the cost per unit of utility service provided. This rate structure is the easiest to determine, is likely to be more accurate in recovering project costs, and is the simplest to manage administratively.
2. Variable Rate
A variable or differential rate structure is a more complex structure that charges higher rates during what would normally be periods of heavy (peak) usage or to have higher rates for certain thresholds of usage. This practice would result in a rate structure that varies by time of use, time of day, or time of year (season) and usually requires extensive and advanced metering to accomplish. An advantage of this structure is to encourage conservation and reduce energy usage during peak periods, as users are

YOSEMITE NATIONAL PARK UTILITIES BRANCH

SEWER SYSTEM MANAGEMENT PLAN

EL PORTAL

SANITARY SEWER SYSTEM (CS 5SSO10735)

financially motivated to reduce utility usage or shift such usage away from peak periods. The rates for this structure should be set under the assumption that there will be reduced consumption as the customer responds to the price change. In addition to the general benefits of energy and utility conservation, reduced or redistributed usage may eliminate or at least postpone the need to expand the capacity of the physical utility plant providing the utility service.

3. Fixed Fee Plus Variable Rate

A fixed fee plus variable rate has a fixed fee component that is assessed for a period of time (monthly, semiannually, or annually) and addresses fixed items in the rate structure that would occur regardless of usage volume; the structure includes a variable fee component that is associated with the actual usage of the user. This rate structure is useful in situations where the system has a high percentage of fixed costs that would remain even if usage were reduced. With reduced usage, revenues decrease and would not cover the fixed costs that remain. In those cases, a high unit rate may tend to discourage usage, but costs would not be commensurately reduced, and the park unit might find that the charges do not cover the full costs of operations.⁴

4 Reference Manual – 35B Reference Manual for the Cost Recovery for National Park Service Provided Utilities; Park Facility Management Division, February 2012, page 3.

YOSEMITE NATIONAL PARK UTILITIES BRANCH

SEWER SYSTEM MANAGEMENT PLAN EL PORTAL SANITARY SEWER SYSTEM (CS 5SSO10735)

The sanitary sewer collection and treatment system for El Portal consists of five distinct sewer collection systems and one wastewater treatment system. All wastewater generated from the five distinct developed areas are discharged into the sewer main coming from Yosemite Valley and piped to the El Portal wastewater treatment system for final wastewater treatment and disposal; except, sewer from the El Portal Maintenance Complex is directly pumped and piped to the wastewater treatment facility. Manholes (MH #1 through MH #58) are part of the sewer main from Yosemite Valley and are assessed and included in the SSMP for El Portal and its developed area.

The five distinct developed areas of El Portal consist of:

1. The El Portal Maintenance Complex sewer collection system services various administrative and maintenance facilities supporting YNP activities. The facilities include park administration buildings, vehicle and equipment storage, warehouses for material storage, and various maintenance shops to support roads and trails, high voltage, telecom, forestry, locksmith, signs, building and grounds, historic preservation, and vehicle maintenance.

The sewer system for the maintenance complex includes approximately 5 manholes, 1150 linear feet (lf) of 6-inch diameter gravity sewer main, an oil/water separator in the equipment maintenance facility, a lift station with 350 lf of 3 inch diameter force main that pumps wastewater from the administrative offices to a manhole near the northern corner of building 759, and a lift station with 400 lf of 4 inch diameter force main that pumps all Maintenance Complex wastewater to the El Portal wastewater treatment facility.

2. The Rancheria Flat sewer system services approximately 62 apartment units, 42 single family dwellings; community recreational facilities with tennis courts, ball field, and swimming pool, and a public school with library. There are no overnight camping facilities or commercial businesses within Rancheria Flat. The apartment units and single family dwellings within Rancheria Flat are 1 to 4 bedroom structures primarily utilized by NPS full-time and seasonal employees. The sewer system includes approximately 340 lf of 8-inch diameter piping, 6,750 lf 6-inch diameter piping, 75 lf of 4-inch diameter piping, and 77 manholes.

YOSEMITE NATIONAL PARK UTILITIES BRANCH

SEWER SYSTEM MANAGEMENT PLAN

EL PORTAL

SANITARY SEWER SYSTEM (CS 5SSO10735)

3. The Trailer Court area (also known as the Trailer Park (TP)) provides year-round and seasonal hook-ups for trailers and recreational vehicles largely for concession employees. There are approximately 20 permanent trailer homes with capacity to accommodate at least an additional 50 seasonal hookups. There are no commercial businesses within the Trailer Court area, except for a small coin-operated laundry facility. The sewer system within the Trailer Court consists of approximately 30 manholes, 4,120 lf of 6 inch diameter piping, and one sewer lift station with 350 lf of 4 inch diameter force main. The lift station consists of duplex 30 hp grinder pumps that conveys sewer from the Trailer Court to the sewer manhole RF 34A serving Rancheria Flat. A diesel powered generator is housed adjacent to the lift station for emergency use.
4. The Old El Portal area is the largest of the sewer service areas within El Portal and is comprised of various community services and housing for NPS and other park staff. Community services include fire station, community hall, post office, grocery and deli, park ranger station, Motor Inn cabins, chapel, fuel storage and distribution facility, fuel service station, and community park. There are approximately 80 residences within Old El Portal that are 2 and 3 bedroom single residence structures. The sewer system consists of approximately 94 manholes, 40 lf of 3 inch diameter sewer laterals, 900 lf of 4 inch diameter gravity sewer piping, 8,000 lf of 6 inch diameter gravity sewer piping and four small sewer lift stations that service 1) the fuel storage and distribution facility, 2) ranger station, 3) the Old Hotel and Motor Inn Cabins, and 4) a residential area near building 5638.
5. The Yosemite View Lodge lies in the eastern sector of El Portal and provides tourist accommodations in a multi-story lodging complex that includes: 335 guest rooms and suites with kitchenettes, one indoor and three outdoor pools, indoor and several outdoor spas, two onsite restaurants, onsite laundry facility, and convenience store. A description of the sewer system within Yosemite View Lodge area is not available. Sewer flows from the Yosemite View Lodge are discharged into MH 48 that flows westward to the El Portal wastewater treatment facility.

YOSEMITE NATIONAL PARK UTILITIES BRANCH

SEWER SYSTEM MANAGEMENT PLAN

EL PORTAL

SANITARY SEWER SYSTEM (CS 5SSO10735)

The developed areas are mapped in Section 4, Figures 4.3 through 4.9.

Most of the El Portal system is not metered. Many of the users are NPS facilities that are not charged sewer fees. Some of the facilities that are operated commercially or by a concessionaire and that pay sewer fees through contract with NPS include:

- Trailer Park concessionaire employee housing with coin operated laundry,
- El Portal fire station, community hall, post office, grocery and deli, Motor Inn cabins, chapel, fuel storage and distribution facility, fuel service station, and community park,
- Yosemite View Lodge

Currently, the concessionaire is charged a combined rate of \$31.23 for water and sewer per 1,000 gallons of water used. With the water rate currently set at \$10.43/1,000gal and the sewer rate set at \$20.80/1,000gal. Where sewer consists of two thirds of the combined rate. Meter reading and billing is processed through the Park's Utility Star program and mailed to the concessionaire by the Park's Administrative Division.

The single unit rate was determined as the most equitable rate structure for all users in the El Portal sewer collection system because the operation and maintenance costs of the collection system do not include a significant proportion of variable costs associated with volume of usage. The operation and maintenance costs are primarily proportional to the sewer service provided. In addition, there is not a portion of the sewer collection system that is isolated from the remainder of the collection system. This type of configuration can result in a disproportionate amount of operation and maintenance costs associated with the isolated facility if it has a long sewer collection main that serves a limited number of sewer connections.

The single unit rate for a wastewater utility should be set using some sort of measuring device. Measurements of wastewater quantities through sewer flow metering practices for single residential flows typically are not reliable. However, there has been a long standing relationship between the quantity of water used in a single-family residential home and the quantity of sewer outflow produced. Some water is used for drinking water or irrigation and does not become sewerage flow however, the amount of water consumed in a household is small and very little water is used for irrigation purposes in El Portal. As such, quantifying wastewater usage can be achieved through metering of domestic water of all facilities for both NPS and non-NPS users. Although there is no

YOSEMITE NATIONAL PARK UTILITIES BRANCH

SEWER SYSTEM MANAGEMENT PLAN EL PORTAL SANITARY SEWER SYSTEM (CS 5SSO10735)

mandate, a set charge per unit quantity of water utilized could be the common measurement. The El Portal water system is slated for meter installations for xxxx.

13.3 COLLECTION SYSTEM COSTS

There are a variety of components and systems that are associated with providing sewer collection services. It is necessary to capture the associated costs from these various components and systems in the determination of a representative and equitable rate for the recovery of those costs. The costs for the operation and maintenance of the El Portal sewer collection system are completed by NPS staff tasked solely with the responsibility for the operation of the El Portal sewer collection system. As a result, there are staff, equipment, and facilities available year round to contribute directly to the operation and maintenance of the El Portal sewer collection system. The basis for the assignment of costs will be based on the operation and maintenance schedules of this manual.

Utility Systems Repairer Operator (USRO) staff labor-rate assumptions were taken from NPS data sheets. Representative labor rates were identified from Salary Table 2010-RUS effective January 2010 and are subject to adjustment. Job titles and pay grades were selected from Yosemite organization charts and may be subject to adjustment for actual personnel.

Generally, labor rates used for budgeting reflect median step for the identified grade. For example, a Grade -10 uses a base pay rate of \$28.38 for step 5, and is assigned a benefit of 35% for a total cost of \$38.31/hour. The base pay rate does not include indirect labor costs such as annual and sick leave. These indirect labor costs are determined by adding a leave surcharge to the total personal service charges. A leave surcharge of 16 percent is representative of the overall average of indirect costs for leave across the NPS⁵. Inflationary factors for federal pay comparability increases and training costs have not been taken into account for base pay rate analysis.

For utility collection-cost labor purposes, the following summary of persons and rates have been employed to derive representative maintenance budgets.

5 Reference Manual – 35B Reference Manual for the Cost Recovery for National Park Service Provided Utilities; Park Facility Management Division, February 2012, page 9

YOSEMITE NATIONAL PARK UTILITIES BRANCH

SEWER SYSTEM MANAGEMENT PLAN

EL PORTAL

SANITARY SEWER SYSTEM (CS 5SSO10735)

TABLE 13.1
Utility Systems Repairer Operator (USRO)
Representative Staff Labor-Rates

Description	Grade / Step 5	Base Rate	Benefit (35%)	Leave Surcharge (16%)	Total Cost
Leader	10	\$30.77	\$9.93	\$6.13	\$46.83
Electrician	10	\$28.38	\$9.93	\$6.13	\$44.44
USRO	9	\$25.77	\$9.02	\$5.57	\$40.36
USRO	7	\$21.07	\$7.37	\$4.55	\$32.99
Admin. Support	5	\$17.00	\$5.95	\$3.67	\$26.62

Incurring costs captured are separated into three groups; operations and maintenance, component renewal, and recapitalization/new capital improvement.

13.3.1 SYSTEM OPERATION AND MAINTENANCE COSTS (RECOVERY OF O&M COSTS)

The operation and maintenance costs for the El Portal sewer collection system consists of costs for all personnel services, supplies, power, and equipment repairs necessary for the sewer collection system to continue to function. These costs are associated in the following areas:

1. Routine manhole inspections (Section 4.3.2),
2. Routine sewer line cleaning (Section 4.3.2)
3. Lift Station
 - a. Electrical power,
 - b. Routine Lift Station Inspection (Section 4.3.3),
 - c. Repair of pumps, motors, and electrical and mechanical equipment,
 - d. Cost of maintaining standby power
4. Oil/water separator (Section 4.3.5)

YOSEMITE NATIONAL PARK UTILITIES BRANCH

SEWER SYSTEM MANAGEMENT PLAN EL PORTAL SANITARY SEWER SYSTEM (CS 5SSO10735)

A. ROUTINE MANHOLE INSPECTION COST RECOVERY

Section 4.3.2 identifies the El Portal sewer collection system manholes that are scheduled to be visually inspected in Table 4.1. Except for the 16" mainline, the NPS plans to visually inspect every sewer manhole and cleanout in the wastewater collection system once every 5 years with its USRO staff with the 16" mainline receiving inspection every 3 years. For the purpose of this study, a five year recurrence will be used. The inspection schedules calls for 10 manhole inspections in the first year, 25 manhole inspections in the second year, 86 manhole inspections in the third year, and 23 manhole inspections in the fourth year, and 34 manhole inspections in the final year. Therefore, the average manhole inspection frequency is 35.6 manhole inspections per year.

The inspection procedure discussed in Section 4.3.2 involve the visual inspection of a manhole, completing Exhibit 4.2, Manhole Inspection Form, and reporting in summary form the conditions of the inspected manhole. "Normally, O&M rates are calculated on a unit cost basis from the previous year's usage and O&M costs."⁶ The Park does not have historical cost data from FMSS as the manhole inspection requirement is a new condition of this Sewer System Management Plan (SSMP). Therefore, a study was conducted under field conditions to quantify the time involved in conducting the inspections.

A two-person crew assembled the necessary gear from a field office to conduct the survey. In addition to personnel safety clothing and vests, field gear was listed as:

- Pickup Truck equipped with Traffic Cones or Portable Barricades,
- Handheld Garmin eTrex Venture HC, and
- Spotlight, Tape Measure, Broom, Small Sledge Hammer and Manhole Lid Hook.

Other essentials included a map of manhole locations, clipboard, and multiple copies of the manhole inspection form. Maps with manhole designation and inspection forms were printed as part of the preparation of field equipment.

⁶ Section 5.1.1 Reference Manual 35B, page 8.

YOSEMITE NATIONAL PARK UTILITIES BRANCH

SEWER SYSTEM MANAGEMENT PLAN

EL PORTAL

SANITARY SEWER SYSTEM (CS 5SSO10735)

The work consisted of arriving at an identified manhole, stopping the vehicle in close proximity with warning lights flashing, and placement of traffic cones about vehicle and site. Where the manholes were in a roadway with traffic, care was taken not to impede traffic. Dirt and debris were removed from the perimeter of the manhole lid before removal to minimize impact to the collection lines. The GPS unit was activated and coordinates and other location data was gathered. The lid was removed. While one person filled out the form, the other performed the assessment. The manhole ring was cleared of debris to insure the lid would set firmly back in place. Once the data was gathered and the lid set back and checked, the cones were gathered up and the vehicle was moved to the next site. At the office, the field notes and coordinates were entered into the database. Field equipment was stored and a spreadsheet summary with recommended action was printed for management review.

Eleven manholes were inspected and data filed. The total lapsed time was 3.75 hours for the two person crew. This resulted in 20.5 minutes per manhole. A time of 20 minutes per manhole accounted for preparation time, travel time between manholes, field time, and the office reporting tasks.

The manhole inspections are planned to be completed by a two person crew consisting of two (2) USROs. The personnel to perform the manhole inspections are based in El Portal therefore travel time is not shown in Table 13.2 as an additional time. The total personnel hours required to fulfill the routine manhole inspection requirements of Section 4.3.2 are:

YOSEMITE NATIONAL PARK UTILITIES BRANCH

SEWER SYSTEM MANAGEMENT PLAN EL PORTAL SANITARY SEWER SYSTEM (CS 5SSO10735)

TABLE 13.2
Annual – 5 Year Revolving Manhole Inspection Costs

Position Description (Grade)	Rate (\$/hr)	Hour	Total
USRO (9)	\$40.36	0.33	\$13.32 / MH
USRO (7)	\$32.99	0.33	\$10.89 / MH
Total per Manhole			\$24.21 / MH
Total Inspection per Year (35.6 Manholes)		11.75 / Helper	\$861.88 / year
Total			\$861.88 / year
Administrative Overhead (15%) ⁷			\$129.28 / year
Total per Year			\$991.16 / year

B. ROUTINE SEWER LINE CLEANING COST RECOVERY

Section 4.3.2 identifies the frequency of sewer line cleaning and the locations within the El Portal collection system. NPS plans to clean the pipe segments shown in Table 4.2 at least once every 5 years.

The Park anticipates that these cleaning services will be performed by an independent contractor. The Class C cost estimates for the pipelines identified in Table 4.2 in 2017 are \$13,348.70.

⁷ Reference Manual – 35B Reference Manual for the Cost Recovery for National Park Service Provided Utilities; Park Facility Management Division, February 2012, page 8.

YOSEMITE NATIONAL PARK UTILITIES BRANCH

SEWER SYSTEM MANAGEMENT PLAN

EL PORTAL

SANITARY SEWER SYSTEM (CS 5SSO10735)

The applications of these costs to the sewer collection rate are distributed over the equivalent service life of each service. The equivalent service life of the cleaning to be performed in 2017 is 5 years. Therefore, the distributed equivalent costs shall be 1/5 of \$13,348.70 for a total of \$2,669.74/year.⁸

C. ROUTINE LIFT STATION INSPECTION & MAINTENANCE COST RECOVERY

Section 4.3.3 identifies the inspection frequency and content for the following seven lift stations in El Portal sewer collection system.

One large and one small lift station in the Maintenance Complex area. [The submittal of asset numbers by the park for these lift stations is pending.

One large lift station in Abbyville serving the Trailer Court/Park area with asset no. 31037.

Four small lift stations in the Old El Portal area that includes:

- i. Lift station serving the Motor Inn, asset no. 1019374
- ii. Lift station serving the El Portal Market, asset no. 31035.
- iii. Lift station serving the Resource Management & Science, asset no. 31038.
- iv. Lift station serving the petroleum bulk plant, asset no. 1090747.

For the purpose of this rate study, maintenance of the lift stations will be separated into two categories. One for the large lift stations and one for the small lift stations.

The Utility Systems Repairer Operator (USRO) staff performs daily, weekly, quarterly, bi-annual and annual inspections of the lift stations. NPS has planned periodic inspections to ensure that the pump stations are being operated in accordance to the manufacturers' recommendation and specific conditions that the USRO staff has developed based on their observations and experience of the pump stations operation in the local conditions of the Park. The Park does not have historical cost data from FMSS as the lift station inspection requirement is a new condition of this SSMP. The personnel to perform the lift station inspections are based in El Portal therefore travel time is not given.

⁸ Reference Manual – 35B Reference Manual for the Cost Recovery for National Park Service Provided Utilities; Park Facility Management Division, February 2012, page 10

YOSEMITE NATIONAL PARK UTILITIES BRANCH

SEWER SYSTEM MANAGEMENT PLAN

EL PORTAL

SANITARY SEWER SYSTEM (CS 5SSO10735)

C.1 DAILY / WEEKLY ROUTINE LIFT STATION INSPECTION COST RECOVERY

USRO staff performs daily/weekly inspection of the lift station. This inspection is a cursory inspection of the facility to ensure that the lift station is operational and there have been no SSOs. The staff will record pump hours for each pump and the amount of pumped flow if the lift station has a flow meter. A check is made for signs of leaks around valves and piping that might indicate wear, failure, excessive vibration, or abnormal sounds. A check is made for abnormal grease balls and cake buildup. The lift station pumps are run in manual mode and test the alarm system to ensure proper operation of each function. Trash and debris is removed from the wet well. The wet well is washed down with a portable jet spray as needed. Once a week, the emergency generator is checked for fuel, oil, water and battery cell levels. It is also checked for fuel line leaks. The generator amp meter is checked and the generator is tested for automatic start up. This would include a SCADA check as all three lift stations have alarm capability through SCADA and local alarm lighting.

Based upon staff experience, the daily inspection can be accomplished by a collection system helper in approximately 2 man hours⁹. The weekly inspection can be accomplished by a collection system helper in approximately 3 man hours⁶. The total costs required to fulfill the daily lift station inspection requirements of Section 4.3.3 are shown in Table 13.3 and the total costs required to fulfill the weekly lift station inspection requirements of Section 4.3.3 are shown in Table 13.4.

⁹ Inspection times for lift station inspection tables are based on times similar to those shown in Wawona Lift Station Section 9.03 Bullet Operations Plan for 2-20hp pumps and adjusted to SSMP O&M inspection guidelines.

YOSEMITE NATIONAL PARK UTILITIES BRANCH

SEWER SYSTEM MANAGEMENT PLAN EL PORTAL SANITARY SEWER SYSTEM (CS 5SSO10735)

**TABLE 13.3
Daily Routine Lift Station Inspection Costs**

Position Description	Rate	Hour	Total
USRO (9)	\$40.36	2	\$80.72 / inspection / station
Total per Inspection			\$80.72 / inspection / station
Subtotal per Year (Total 313 inspection days/year) ¹⁰		626	\$25,265.36 / year / station
Administrative Overhead (15%) ¹¹			\$3,789.80 / year / station
Total per Year per station			\$29,055.16
Total for seven stations per Year			\$203,386.15

10 The Park inspects the lift station every day of the year. However, the daily inspections will occur as part of the weekly, monthly, quarterly, bi-annual, and annual inspections. Therefore, the total days of daily inspections are 313 days.

11 Reference Manual – 35B Reference Manual for the Cost Recovery for National Park Service Provided Utilities; Park Facility Management Division, February 2012, page 8.

YOSEMITE NATIONAL PARK UTILITIES BRANCH

SEWER SYSTEM MANAGEMENT PLAN

EL PORTAL

SANITARY SEWER SYSTEM (CS 5SSO10735)

TABLE 13.4
Weekly Routine Lift Station Inspection Costs

Position Description	Rate	Hour	Total
USRO (9)	\$40.36	3	\$121.08 / inspection / station
Total per Inspection			\$121.08 / inspection / station
Subtotal per Year (Total days X 40) ¹²		120	\$4,843.20 / year / station
Administrative Overhead (15%) ¹³			\$726.48 / station
Total per Year per station			\$5,569.68
Total for seven stations per Year			\$38,987.76

C.II MONTHLY ROUTINE LIFT STATION INSPECTION COST RECOVERY

USRO staff performs monthly inspection of the collection system lift stations as described in Section 4.3.3. The monthly inspections are more extensive inspections of the facility than both the daily and weekly inspections. The monthly inspections are intended to ensure that the other components of the lift station are in an operational position. The staff will perform the daily and weekly inspection and will also visually inspect the wet well by pumping the water levels down. Hose the wet well down during the pump down process. Clean and inspect floats of any grease buildup or rags. Record amp readings on each motor in the lift station.

12 The Park inspects the lift station every day of the year. However, the weekly inspections will occur as part of the monthly, quarterly, bi-annual, and annual inspections. Therefore, the total days of daily inspections are 40 days.

13 Reference Manual – 35B Reference Manual for the Cost Recovery for National Park Service Provided Utilities; Park Facility Management Division, February 2012, page 8

YOSEMITE NATIONAL PARK UTILITIES BRANCH

SEWER SYSTEM MANAGEMENT PLAN

EL PORTAL

SANITARY SEWER SYSTEM (CS 5SSO10735)

Based upon staff experience, the monthly inspection can be accomplished by a collection system leader and USRO in approximately 4 man hours. The total costs required to fulfill the monthly lift station inspection requirements of Section 4.3.3 are shown in Table 13.5.

TABLE 13.5
Monthly Routine Lift Station Inspection Costs

Position Description	Rate	Hour	Total
Leader (10)	\$46.83	2.0	\$93.66 / inspection / station
USRO (9)	\$40.36	2.0	\$80.72 / inspection / station
Total per Inspection per station			\$174.38
Total per Year		(8) ¹⁴	\$1,395.04 / year / station
Administrative Overhead (15%) ¹⁵			\$209.26 / station
Total per Year per station			\$1,604.30
Total for seven stations per Year			\$11,230.07

14 The total of monthly inspections are reduced to eight with the assumption that the quarterly, bi-annual and annual inspection will be completed in place of the monthly inspection schedule.

15 Reference Manual – 35B Reference Manual for the Cost Recovery for National Park Service Provided Utilities; Park Facility Management Division, February 2012, page 8.

YOSEMITE NATIONAL PARK UTILITIES BRANCH

SEWER SYSTEM MANAGEMENT PLAN EL PORTAL SANITARY SEWER SYSTEM (CS 5SSO10735)

C.III QUARTERLY ROUTINE LIFT STATION INSPECTION COST RECOVERY

USRO staff performs a quarterly inspection of the lift station. This inspection is more extensive in detail of the facility than the daily, weekly and monthly inspections. The staff will also perform the daily and weekly inspection. The quarterly inspection of pumps is intended to ensure that the pump impellers are free of debris. The generator is also operated under load for 15 minute duration upon tripping the power to test for successful transfer to generator power. All wire terminations are checked for tightness and tightened as needed. All electrical devices are checked.

The quarterly inspection will be accomplished by collection system leader, electrician and USRO. The length of time to perform the quarterly inspection is approximately 4.5 man hours. The total costs required to fulfill the monthly lift station inspection requirements of Section 4.3.3 are shown in Table 13.6.

YOSEMITE NATIONAL PARK UTILITIES BRANCH

SEWER SYSTEM MANAGEMENT PLAN EL PORTAL SANITARY SEWER SYSTEM (CS 5SSO10735)

TABLE 13.6
Quarterly Routine Lift Station Inspection Costs

Position Description	Rate	Hour	Total
Leader (10)	\$46.83	1.5	\$70.25 / inspection / station
Electrician (10)	\$44.44	1.5	\$66.66 / inspection / station
USRO (9)	\$40.36	1.5	\$60.54 / inspection / station
Total per Inspection per station			\$197.45
Total per Year per station		(2) ¹⁶	\$394.89 / year
Administrative Overhead (15%) ¹⁷			\$59.23
Total per Year per station			\$454.12
Total for seven stations per Year			\$3,178.86

16 The total of quarterly inspections are reduced to two with the assumption that the quarterly, bi-annual and annual inspection will be completed in place of the quarterly inspection schedule.

17 Reference Manual – 35B Reference Manual for the Cost Recovery for National Park Service Provided Utilities; Park Facility Management Division, February 2012, page 8.

YOSEMITE NATIONAL PARK UTILITIES BRANCH

SEWER SYSTEM MANAGEMENT PLAN EL PORTAL SANITARY SEWER SYSTEM (CS 5SSO10735)

C.IV BI-ANNUAL ROUTINE LIFT STATION INSPECTION COST RECOVERY

USRO staff performs a bi-annual inspection of the lift station. Measure total dynamic suction head and discharge head as a test. This is especially important where the fluid being pumped tends to form a deposit on internal surfaces. The bi-annual inspection checks for long term wear of system components such as impellers, wear rings, discharge connector seals and includes exercising of the discharge (check) valves and checking for water intrusion into the pumps. The bi-annual inspections are intended to ensure that major components of the lift station maintain an efficient operational condition. The staff will also perform the daily, weekly and monthly inspection.

The bi-annual inspection will be accomplished by collection system leader, electrician and USRO. The length of time to perform the bi-annual inspection is approximately 12 man hours. The total costs required to fulfill the bi-annual lift station inspection requirements of Section 4.3.3 are shown in Table 13.7.

YOSEMITE NATIONAL PARK UTILITIES BRANCH

SEWER SYSTEM MANAGEMENT PLAN EL PORTAL SANITARY SEWER SYSTEM (CS 5SSO10735)

**TABLE 13.7
Bi-Annual Routine Lift Station Inspection Costs**

Position Description	Rate	Hour	Total
Leader (10)	\$46.83	4.0	\$187.32 / inspection / station
Electrician (10)	\$44.44	4.0	\$177.60 / inspection / station
USRO (9)	\$40.36	4.0	\$161.44 / inspection / station
Total per Inspection per station			\$526.36
Total per Year per station		(1) ¹⁸	\$526.36 / year
Administrative Overhead (15%) ¹⁹			\$78.95
Total per Year per station			\$605.31
Total for seven stations per Year			\$4,237.20

18 The total of bi-annual inspections are reduced to one with the assumption that the annual inspection will be completed in place of the bi-annual inspection schedule.

19 Reference Manual – 35B Reference Manual for the Cost Recovery for National Park Service Provided Utilities; Park Facility Management Division, February 2012, page 8.

YOSEMITE NATIONAL PARK UTILITIES BRANCH

SEWER SYSTEM MANAGEMENT PLAN EL PORTAL SANITARY SEWER SYSTEM (CS 5SSO10735)

C.V ANNUAL ROUTINE LIFT STATION INSPECTION COST RECOVERY

USRO staff performs an annual inspection of the lift station. The pumps should be removed annually and inspected in accordance with the pump manufacturer's O&M manual. Remove the rotating element and inspect it thoroughly for wear. Order replacement parts if necessary. Check wearing clearances. Remove any deposits or scaling. The staff will also perform the daily, weekly, monthly, quarterly and bi-annual inspection.

The annual inspection will be accomplished by collection system leader, electrician and USRO. The length of time to perform the annual inspection is approximately 15 man hours. The total costs required to fulfill the annual lift station inspection requirements of Section 4.3.3 are shown in Table 13.8.

YOSEMITE NATIONAL PARK UTILITIES BRANCH

SEWER SYSTEM MANAGEMENT PLAN
EL PORTAL
SANITARY SEWER SYSTEM (CS 5SSO10735)

TABLE 13.8
Annual Routine Lift Station Inspection Costs

Position Description	Rate	Hour	Total
Leader (10)	\$46.83	5.0	\$234.15 / inspection / station
Electrician (10)	\$44.44	5.0	\$222.20 / inspection / station
USRO (9)	\$40.36	5.0	\$201.80 / inspection / station
Total per Inspection per station			\$658.15
Total per Year per station		1	\$658.15 / year / station
Administrative Overhead (15%) ²⁰			\$98.72 / station
Total per Year per station			\$756.87
Total for seven stations per Year			\$5,298.11

20 Reference Manual – 35B Reference Manual for the Cost Recovery for National Park Service Provided Utilities; Park Facility Management Division, February 2012, page 8.

YOSEMITE NATIONAL PARK UTILITIES BRANCH

SEWER SYSTEM MANAGEMENT PLAN EL PORTAL SANITARY SEWER SYSTEM (CS 5SSO10735)

D. OIL / WATER SEPARATOR CLEANING AND INSPECTION COST RECOVERY

Section 4.3.5 identifies the frequency of oil/water separator inspection and cleaning within the El Portal collection system. The NPS should plan to visually inspect the oil/water separator weekly and quarterly as well as during and immediately following maintenance activities and equipment washing. Sludge depths should be determined during the spring and fall months and more frequently during heavy equipment maintenance activities. Sludge removal cycles shall be no greater than five years and may require a shorter cycle based on loading. The tank leak test cycles shall be ten years. Normally, O&M rates are calculated on a unit cost basis from the previous year's usage and O&M costs.²¹ The Park does not have historical cost data from FMSS as the oil/water separator inspection, cleaning and testing requirement is a new condition of this Sewer System Management Plan (SSMP).

D.1 OIL / WATER SEPARATOR INSPECTION COST RECOVERY

The labor required for inspection of the oil/water separator is not expected to vary for the weekly and quarterly inspections. USRO staff performs inspection of the oil/water separator and will be accomplished by USRO. The length of time to perform inspections is approximately 0.5 man hours. The total costs required to fulfill inspection requirements of Section 4.3.5 is shown in Table 13.9.

²¹ Section 5.1.1 Reference Manual 35B, page 8.

YOSEMITE NATIONAL PARK UTILITIES BRANCH

SEWER SYSTEM MANAGEMENT PLAN EL PORTAL SANITARY SEWER SYSTEM (CS 5SSO10735)

TABLE 13.9
Weekly / Quarterly Routine
Oil / Water Separator Inspection Costs

Position Description	Rate	Hour	Total
USRO (9)	\$40.36	0.5	\$20.18 / inspection
Total per Inspection			\$20.18
Total Inspections per Year		52	\$1,049.36 / year
Administrative Overhead (15%) ²²			\$157.40
Total per Year			\$1,206.76

D.II OIL / WATER SEPARATOR SLUDGE REMOVAL COST RECOVERY

Sludge removal shall be based on a five year cycle however, sludge depths exceeding 12 inches, or exceeding 20% tank volume requires sludge removal and may occur more frequently. Hazwaste contractor performs sludge removal from the oil/water separator and will be accomplished by a service contract. After regulatory characterization of the sludge is made it may be pumped out. The service contract shall include pumping, transport, manifesting and disposal off site.

D.III OIL / WATER SEPARATOR LEAK TEST COST RECOVERY

The oil/water separator leak test is accomplished by a service contract.

22 Reference Manual – 35B Reference Manual for the Cost Recovery for National Park Service Provided Utilities; Park Facility Management Division, February 2012, page 8.

YOSEMITE NATIONAL PARK UTILITIES BRANCH

SEWER SYSTEM MANAGEMENT PLAN

EL PORTAL

SANITARY SEWER SYSTEM (CS 5SSO10735)

E. TRAINING, ENERGY & PARTS, MATERIALS SUPPLIES, TOOLS, VEHICLE TOOL COST RECOVERY

Other costs for the operation and maintenance of the sewer system's annual cost include;

1. staff training;
2. energy costs;
3. parts, materials supplies, tools and vehicle tool costs.²³

The annual estimated cost for staff training ranges from \$750 to \$1,400 per year per employee. According to a 2002 report by the American Society of Training and Development, which surveyed more than 375 major corporations, companies spend 1 percent to 3 percent of their total payroll on training. On a per-person basis, the average spent on training is more than \$700 per year. At leading-edge companies, that figure doubles to more than \$1,400 per employee per year.²⁴

An annual cost of \$1,000 per man year will be used for this study. The total number of man hours used for operation and maintenance is approximately 5,731 man hours. Given that 2,080 man hours is equal to one man year we get approximately 2.76 man years. Hence, the cost per year per person for training is estimated at \$2,760. Energy costs, along with parts, materials supplies, tools and vehicle tool costs were derived from the FY2011 Valley Utilities account spending plan along with the 2009 Wastewater Treatment annual totals. The 2009 waste water treatment totals yielded an assumed annual total flow contribution for El Portal of approximately 30%. Associated cost items in FY2011 Valley Utilities account spending plan were prorated using 30% for an estimated annual cost. The total energy cost is estimated at \$51,000 and the total cost for parts, materials supplies, tools and vehicle tool costs is estimated at \$4,500. This information is used to complete a modified "Utility Rate Computation Summary" form presented as Appendix B following Table 13.13 at the end of the rate study and was taken from Appendix H in RM-35B.

²³ NPS RM-35B, Appendix H

²⁴ Tom Casey and Carey Guggenheim, Buck Consultants, June 6, 2005.

YOSEMITE NATIONAL PARK UTILITIES BRANCH

SEWER SYSTEM MANAGEMENT PLAN EL PORTAL SANITARY SEWER SYSTEM (CS 5SSO10735)

13.3.2 COMPONENT RENEWAL (RECOVERY OF FM-PMIS PROJECT WORK COSTS)

As described in RM 35B, Appendix “C”, “Wastewater Utilities Business Practice”, typical projects considered as component renewal include video inspection of lines, CCTV. This type of work is captured in FMSS work orders that are associated with PMIS projects and contribute to the rate as an amortized amount based on the design life of the component.

Section 4.3.2 identifies the frequency of sewer line closed circuit televised (CCTV) inspection and the locations within the El Portal collection system. The NPS plans to proactively CCTV inspect each sewer pipe segment at least once every 15 years.

The Park anticipates that these CCTV inspection services will be performed by an independent contractor. The Class C cost estimate for the CCTV inspection of the El Portal collection system in 2024 is \$22,486.80 for work performed by an independent contractor. The applications of these costs to the sewer collection rate are distributed over the equivalent service life of the component. The equivalent service life of the CCTV inspection to be performed in 2024 is 15 years. Therefore, the distributed equivalent costs shall be 1/15 of \$22,486.80 for a total of \$1,499.12²⁵ for work performed by an independent contractor.

13.3.3 RECAPITALIZATION / CAPITAL IMPROVEMENT COSTS (FY 2012 TO PRESENT)

The sewer collection system in El Portal is fixed and as such is treated as Fixed Capital Equipment (FCE). It is considered to be a part of the rate and only Capital Improvement (CI) work completed during FY 2012 and later may be included in the rate determination. In addition, actual costs are used and they contribute to the rate as an amortized amount based on a design life of 40 years²⁶. This is done only after the actual cost of the work is known and the work order is closed and the total cost of the work is amortized. No FM-PMIS project work orders for CI work have been completed during FY 2012 to be included in this section.

25 Reference Manual – 35B Reference Manual for the Cost Recovery for National Park Service Provided Utilities; Park Facility Management Division, February 2012, page 10

26 RM-35B, Section 5.1.2, page 9

YOSEMITE NATIONAL PARK UTILITIES BRANCH

SEWER SYSTEM MANAGEMENT PLAN

EL PORTAL

SANITARY SEWER SYSTEM (CS 5SSO10735)

13.3.4 CAPITAL IMPROVEMENT PLAN FUTURE COSTS

El Portal sewer pipeline rehabilitation / replacement is considered a Fixed Capital Equipment (FCE). Section 4.4.2 Capital Improvement Plan provides an outline for pipeline rehabilitation / replacement based on an assessment of the sewer line condition utilizing the PACP grading criteria and converting it into an FMSS urgency code index. This section covers capital improvement plan future costs generated from class “C” cost estimates for capital improvement projects to be performed in (0 to 2, 2 to 10 and 10 to 20 years) corresponding to FMSS urgency code indices of 1, 2 or 3 respectively. At this time, El Portal’s sewer collection system has the following sewer pipeline segments, identified in Section 4.4.2, scheduled for rehabilitation / replacement:

- Two segments with an FMSS urgency code of 1 (between 0 to 2 years).
- Forty three segments with an FMSS urgency code of 2 (between 2 to 10 years).
- No segments with an FMSS urgency code of 3 between (10 to 20 years)

The Park anticipates that these CI projects will be performed by an independent contractor. The total cost for the two pipeline segments with FMSS Urgency Index Code No. 1, to be completed within 0 to 2 years is \$34,709, using a two year inflation escalation. The total cost for the forty three pipeline segments with FMSS Urgency Index Code No. 2, to be completed within 2 to 10 years is \$1,353,558, using a ten year inflation escalation. The estimated cost will decrease if projects are completed earlier. The applications of these costs to the sewer collection rate are distributed over the equivalent service life of each service. The equivalent service life of the sewer line is 40 years. Therefore, the distributed equivalent costs shall be 1/40 of \$34,709 and 1/40 of \$1,353,558 for a total of \$34,706.68/year.²⁷

27 Reference Manual – 35B Reference Manual for the Cost Recovery for National Park Service Provided Utilities; Park Facility Management Division, February 2012, page 10

YOSEMITE NATIONAL PARK UTILITIES BRANCH

SEWER SYSTEM MANAGEMENT PLAN EL PORTAL SANITARY SEWER SYSTEM (CS 5SSO10735)

13.3.5 O&M, COMPONENT RENEWAL AND CAPITAL IMPROVEMENT COST SUMMARY

Table 13.10 provides a cost summary for Operation and Maintenance (O&M), Component Renewal (Recovery of FM-PMIS Project Work Costs), Recapitalization Capital Improvement Costs (2012 to Present) and Future Capital Improvement. This information is used to complete a modified "Utility Rate Computation Summary" form presented as Appendix B following Table 13.10 and was taken from Appendix H in RM-35B.

YOSEMITE NATIONAL PARK UTILITIES BRANCH

SEWER SYSTEM MANAGEMENT PLAN EL PORTAL SANITARY SEWER SYSTEM (CS 5SSO10735)

**TABLE 13.10
O&M and Capital Improvement Cost Summary**

Rate Capture Method	Cost Description	Total
Operation and Maintenance (O&M)	Routine Manhole Inspection	\$991.16 / year
	Routine Sewer Line Cleaning	\$2,669.74 / year
	7 Lift Stations Inspection (Daily)	\$203,386.12 / year
	7 Lift Stations Inspection (Weekly)	\$38,987.76 / year
	7 Lift Stations Inspection (Monthly)	\$11,230.07 / year
	7 Lift Stations Inspection (Quarterly)	\$3,178.86 / year
	7 Lift Stations Inspection (Bi-Annual)	\$4,237.20 / year
	7 Lift Stations Inspection (Annual)	\$5,298.11 / year
	Oil/Water Separator Inspection (Weekly / Quarterly)	\$1,206.76 / year
	Training	\$2,760.00 / year
	Energy	\$51,000.00 / year
	Parts, Materials, Supplies, Tools, Vehicle Tool Costs	\$4,500.00 / year

YOSEMITE NATIONAL PARK UTILITIES BRANCH

SEWER SYSTEM MANAGEMENT PLAN
EL PORTAL
SANITARY SEWER SYSTEM (CS 5SSO10735)

TABLE 13.10 (Continued)
O&M and Capital Improvement Cost Summary

Rate Capture Method	Cost Description	Total
Component Renewal (Recovery of FM-PMIS Project Work Costs)	Routine Sewer Line CCTV	\$1,499.12 / year
Recapitalization Capital Improvement Costs (2012 to Present)	None Available	\$0 / year
Future Capital Improvement	Pipe Replacement	\$34,706.68 / year
	Total per Year	\$365,651.58

YOSEMITE NATIONAL PARK UTILITIES BRANCH

SEWER SYSTEM MANAGEMENT PLAN EL PORTAL SANITARY SEWER SYSTEM (CS 5SSO10735)

GLOSSARY

YOSEMITE NATIONAL PARK UTILITIES BRANCH

SEWER SYSTEM MANAGEMENT PLAN EL PORTAL SANITARY SEWER SYSTEM (CS 5SSO10735)

GLOSSARY

ABS

Acrylonitrile-Butadiene-Styrene

ANSI

American National Standards Institute: A private non-profit organization that oversees the development of voluntary consensus standards for products, services, processes, systems, and personnel in the United States.

ASTM

American Society for Testing and Materials: An international standards organization that develops and publishes voluntary consensus technical standards for a wide range of materials, products, systems, and services.

AWG

American Wire Gage

AWWA

American Water Works Association

BCU

Back Country Utilities

Blockage

A build up of debris in the sewer, which stops the flow of wastewater and allows the water to back up behind the stoppage, sometimes causing an overflow. Also called a stoppage.

YOSEMITE NATIONAL PARK UTILITIES BRANCH

SEWER SYSTEM MANAGEMENT PLAN

EL PORTAL

SANITARY SEWER SYSTEM (CS 5SSO10735)

BMP

Best Management Practices: Activities, practices, facilities, and/or procedures that when implemented to the maximum extent practicable will prevent or reduce pollutants in discharges.

Building Sewer

The piping that conveys sewage within a building or residence.

CCTV

Closed Circuit Television: Refers to the process and camera equipment that are used to internally inspect the condition of gravity sewers.

Certification of SSO Reports

The SWRCB requires the Legally Responsible Official to login to CIWQS within a given time period to electronically sign submitted reports thereby stating that to the best of his/her knowledge and belief, the information submitted is true, accurate, and complete.

CIP Program

Capital Improvement Plan: Refers to the document that identifies planned capital improvements for the wastewater collection systems within the Yosemite National Park.

CIWQS

California Integrated Water Quality System: Refers to the State Water Resources Control Board online electronic reporting system that is used to report SSOs, certify completion of the SSMP, and provide information on the sanitary sewer system. The electronic reporting requirement became effective on January 2, 2007 for Region 6.

YOSEMITE NATIONAL PARK UTILITIES BRANCH

SEWER SYSTEM MANAGEMENT PLAN EL PORTAL SANITARY SEWER SYSTEM (CS 5SSO10735)

CO

Clean Out: An engineered Y-Branch or TEE in the sewer piping system with a cap on the end used for cleaning out the sewer lateral lines between the sewer piping mainline and structures.

Collection System

See Wastewater Collection System.

CSM

Collection Systems Maintenance Grade

CVRWQC Board

Central Valley Regional Water Quality Control Board

CWEA

California Water Environment Association

CY

Calendar Year: Period from January 1st through December 31st.

DR

Dimension Ratio

YOSEMITE NATIONAL PARK UTILITIES BRANCH

SEWER SYSTEM MANAGEMENT PLAN EL PORTAL SANITARY SEWER SYSTEM (CS 5SSO10735)

DVD

Digital Video Disk

EPA

The United States Environmental Protection Agency.

FMSS

Facilities Management Software System that is used to manage maintenance and condition assessment data including the production of work orders and the recording of work completed.

FOG

Fats, Oils, and Grease: Refers to fats, oils, and grease typically associated with food preparation and cooking activities that can cause blockages in the sanitary sewer system.

Force Main

A pressure sewer used to convey wastewater from a lift station to the point of discharge into a gravity sewer line.

FSE

Food Service Establishment: Refers to commercial or industrial facilities where food is handled/prepared/served that discharge to the wastewater collection system.

FY

Fiscal Year: The federal fiscal year starts in October 1st and ends September 30th.

YOSEMITE NATIONAL PARK UTILITIES BRANCH

SEWER SYSTEM MANAGEMENT PLAN

EL PORTAL

SANITARY SEWER SYSTEM (CS 5SSO10735)

GIS

Geographical Information System: A computer software system utilized by Design and Engineering Branch for Yosemite National Park that captures, stores, analyzes, and manages geospatial data associated with the Park's wastewater collection system assets. The database is linked to mapping, which includes various layers of information used by government officials. Examples of information found on a GIS include a sewer map and sewer features such as pipe location, diameter, material, condition, and last date cleaned or repaired. The GIS also typically contains base information such as streets and parcels.

GMP

Grease Management Plan: A plan implemented to substantially reduce or eliminate the discharge of grease into the sewer system.

GPD

Gallons Per Day: Units of flow measurement.

GPM

Gallons Per Minute: Units of flow measurement.

GPS

Global Positioning System: The handheld unit used to determine the longitude and latitude of sanitary sewer overflows for use in meeting CIWQS reporting requirements.

GRD

Grease Removal Device: Refers to grease traps or grease interceptors that are installed to remove FOG from the wastewater flow at food service establishments.

YOSEMITE NATIONAL PARK UTILITIES BRANCH

SEWER SYSTEM MANAGEMENT PLAN EL PORTAL SANITARY SEWER SYSTEM (CS 5SSO10735)

GRD –Hotspot

A gravity sewer identified as requiring frequent preventive maintenance to reduce the likelihood of SSOs.

HDPE

High Density Polyethylene

hp

Horsepower: Unit of energy.

IBM

International Business Machine: Hardware and software manufacturing company.

ID

Identification

IDP

Individual Development Plan: A typical worker development and training program for NPS wastewater collections staff. Synonymous with ITP.

YOSEMITE NATIONAL PARK UTILITIES BRANCH

SEWER SYSTEM MANAGEMENT PLAN

EL PORTAL

SANITARY SEWER SYSTEM (CS 5SSO10735)

I & I

Infiltration / Inflow: The combined affects from infiltration and inflow. Infiltration enters the sewer system through openings such as: displaced or open pipe joints; cracks, fractures and breaks in the fabric of the main sewer and lateral connections, and manhole chambers. Maximum infiltration typically occurs during periods of high groundwater caused from snow melt, spring runoff, precipitation, and/or irrigation. Inflow results from faulty manhole covers, improper sewer connections such as downspouts and groundwater sump pumps discharge water into the sewer system, and from surface water sewers/drains and land drainage connections.

IPS

Iron Pipe Size

ITP

Individual Training Program, synonymous with IDP.

Lateral

See Sewer Service Lateral.

Lift Station

Used interchangeably with the term pump station.

MGD or mgd

Million Gallons per Day

YOSEMITE NATIONAL PARK UTILITIES BRANCH

SEWER SYSTEM MANAGEMENT PLAN EL PORTAL SANITARY SEWER SYSTEM (CS 5SSO10735)

MH

Manhole: An engineered structure that is intended to provide access to a sanitary sewer for maintenance and inspection.

MRP

Monitoring and Reporting Program

MS4

Municipal Separate Storm Sewer Systems

NA

Not Applicable

NASCCO

National Association of Sewer Service Companies: www.nassco.org.

Notification of an SSO

The regulatory reporting of sewer system overflows when the USRO staff first becomes aware of the SSO incident.

NPDES

National Pollution Discharge Elimination System: The regulatory program administered by EPA for permitting and controlling wastewater discharges to Waters of the State.

NPS

National Park Service

YOSEMITE NATIONAL PARK UTILITIES BRANCH

SEWER SYSTEM MANAGEMENT PLAN EL PORTAL SANITARY SEWER SYSTEM (CS 5SSO10735)

NPT

National Pipe Thread

OD

Outer Diameter

OERP

Overflow Emergency Response Plan: A plan within the Sewer System Management Plan that is designed to provide written guidance for staff to properly and effectively respond, contain, secure, and report sewer system overflows while minimizing environmental impacts that may be created from sewer system overflows.

OES

Office of Emergency Services: The California Governor's Office of Emergency Services; also referred to as Emergency Management Agency.

O&M

Operations and Maintenance

Online SSO Reporting System

The California Integrated Water Quality System (CIWQS).

OSHA

Occupational Safety and Health Administration

YOSEMITE NATIONAL PARK UTILITIES BRANCH

SEWER SYSTEM MANAGEMENT PLAN EL PORTAL SANITARY SEWER SYSTEM (CS 5SSO10735)

PACP

NASSCO Pipeline Assessment Certification Program

PE

- Polyethylene
- Professional Engineer

PI

Performance Indicator: An indication of the level of performance of an SSMP element.

PLSD

Private Lateral Sewage Discharge: A category of sewage discharge caused by blockages or other problems within a privately owned lateral.

PM

Preventative Maintenance: Maintenance activities intended to prevent failures of the wastewater collection system facilities (e.g. cleaning, CCTV, inspection).

POC

Point of Contact

PPE

Personal Protective Equipment to include headgear, eyewear, coveralls, footgear, gloves, respirators, etc.

YOSEMITE NATIONAL PARK UTILITIES BRANCH

SEWER SYSTEM MANAGEMENT PLAN EL PORTAL SANITARY SEWER SYSTEM (CS 5SSO10735)

psig

Pressure per Square Inch Gage

Pump Station

Used interchangeably with the term lift station.

PVC

Polyvinyl Chloride pipe

QA/QC

Quality Assurance and Quality Control

R&R

Rehabilitation and Replacement

SCADA

Supervisory Control and Data Acquisition system: An electronic system that is used to monitor lift station performance and to initiate alarms when monitored parameters exceed pre-set limits.

SDR

Standard Dimension Ratio: A method of rating pressure piping and is the ratio of pipe diameter to wall thickness.

YOSEMITE NATIONAL PARK UTILITIES BRANCH

SEWER SYSTEM MANAGEMENT PLAN EL PORTAL SANITARY SEWER SYSTEM (CS 5SSO10735)

SECA Plan

System Evaluation and Capacity Assurance Plan

Sensitive Area

Areas where an SSO could result in a fish kill or pose an imminent or substantial danger to human health (e.g. parks, aquatic habitats, etc.)

Sewer Main

The primary piping for the conveyance of wastewater to the wastewater treatment facility. Sewer mains are owned and maintained by National Park Service, Yosemite National Park.

Sewer Service Lateral

The piping that conveys sewage from the building to the wastewater collection system.

Sewer System

See Wastewater Collection System.

SOP

Standard Operating Procedures: Written procedures that pertain to specific activities employed in the operation and maintenance of the wastewater collection system.

SSMP

Sewer System Management Plan

YOSEMITE NATIONAL PARK UTILITIES BRANCH

SEWER SYSTEM MANAGEMENT PLAN

EL PORTAL

SANITARY SEWER SYSTEM (CS 5SSO10735)

SSO

Sanitary Sewer Overflow: Any overflow, spill, release, discharge or diversion of untreated or partially treated wastewater from a sanitary sewer system. SSOs include:

- (i) Overflows or releases of untreated or partially treated wastewater that pipe segment waters of the United States;
- (ii) Overflows or releases of untreated or partially treated wastewater that do not pipe segment waters of the United States; and
- (iii) Wastewater backups into buildings and on private property that are caused by blockages or flow conditions within the publicly owned portion of a sanitary sewer system.

Stoppage

A build up of debris in the sewer, which stops the flow of wastewater and allows the water to back up behind the stoppage, sometimes causing an overflow. Also called blockage.

Surface Waters

See Waters of the State.

SWRCB

State Water Resources Control Board: The California Environmental Protection Agency (EPA) State Water Resources Control Board and staff responsible for protecting the State's water resources.

TCP

Technical Certification Program

YOSEMITE NATIONAL PARK UTILITIES BRANCH

SEWER SYSTEM MANAGEMENT PLAN EL PORTAL SANITARY SEWER SYSTEM (CS 5SSO10735)

THHN

Thermoplastic High Heat Resistant Nylon-coated: Insulation for electrical wiring.

THWN

Thermoplastic Heat & Water Resistant Nylon-coated: Insulation for electrical wiring.

UF

Underground electrical Feeder: A rating used for electrical wiring.

U.L.

Underwriter Laboratories

UPC - California

Uniform Plumbing Code: California State code standard requirements governing the design and sizing of plumbing piping and fixtures and devices.

USA

Underground Service Alert: A nationwide utility locating service to call before you dig.

USB

Universal Serial Bus

USRO staff

Field staff of the Utilities Branch who operate and maintain the wastewater collection system.

YOSEMITE NATIONAL PARK UTILITIES BRANCH

SEWER SYSTEM MANAGEMENT PLAN EL PORTAL SANITARY SEWER SYSTEM (CS 5SSO10735)

VCP

Vitrified Clay Pipe used for sewer main and laterals.

Volume Captured

The amount of spilled sewage that is returned to the wastewater collection system. When recording the volume that is captured, the volume of water used for flushing and/or cleaning should not be included.

Wastewater Collection System

The portion of the sanitary sewer facilities that are owned and operated by the National Park Service to include all pipelines, pump stations, and other facilities upstream of the headworks of the wastewater treatment plant that transport wastewater from its source to the wastewater treatment plant.

Water Body

A water body is any stream, creek, river, pond, impoundment, lagoon, wetland, or bay.

Waters of the State

Waters of the State (or waters of the United States) means any water, surface or underground, including saline waters, within the boundaries of California. In case of a sewage spill, storm drains are considered to be waters of the State unless the sewage is completely contained and returned to the wastewater collection system and that portion of the storm drain is cleaned.

WDR

General Waste Discharge Requirements: The State Water Resources Control Board Order No. 2006-0003, Statewide General Waste Discharge Requirements for Sanitary Sewer Systems, dated May 2, 2006, as revised on February 20, 2008.

YOSEMITE NATIONAL PARK UTILITIES BRANCH

SEWER SYSTEM MANAGEMENT PLAN EL PORTAL SANITARY SEWER SYSTEM (CS 5SSO10735)

WO

Work Order: A document (paper or electronic) that is issued by the FMSS Help DESK and is used to assign maintenance or system improvements to USRO staff.

WWTP

Waste Water Treatment Plant: A sewer treatment plant where raw sewer is treated.

VFD

Variable Frequency Drive

YNP

Yosemite National Park

YOSE

Yosemite

YOSEMITE NATIONAL PARK UTILITIES BRANCH

SEWER SYSTEM MANAGEMENT PLAN EL PORTAL SANITARY SEWER SYSTEM (CS 5SSO10735)

This page left intentionally blank.

YOSEMITE NATIONAL PARK UTILITIES BRANCH

SEWER SYSTEM MANAGEMENT PLAN EL PORTAL SANITARY SEWER SYSTEM (CS 5SSO10735)

APPENDIX A: FOG CONTROL SUPPLEMENT

YOSEMITE NATIONAL PARK UTILITIES BRANCH

SEWER SYSTEM MANAGEMENT PLAN

EL PORTAL

SANITARY SEWER SYSTEM (CS 5SSO10735)

FATS, OILS & GREASE (FOG) CONTROL SUPPLEMENT

- A. Title: This document shall be referred to as the "Yosemite National Park FOG Control Supplement" or "FOG supplement agreement."
- B. Purpose: The purpose of the FOG supplement agreement is to reduce Sanitary Sewer Overflows and blockages, and to protect public health and the environment by minimizing public exposure to unsanitary conditions. By controlling the discharge of fats, oils and grease to the wastewater collection system, excessive buildup in sewer lines can be lessened, thereby increasing the system's operating efficiency and reducing the number of sewer line blockages and overflows.
- C. General FOG Discharge Prohibitions: No Food Service Establishment (FSE) operated by the concessionaire shall discharge or cause to be discharged into the sewer system FOG that may accumulate and/or cause or contribute to blockages in the sewer system or at the sewer lateral which connects the Food Service Establishment to the sewer system.
- D. Specific FOG Prohibitions: The following specific prohibitions shall apply to all Food Service Establishments:
1. Discharge of any FOG-containing wastewater that is not connected to a grease removal device is prohibited.
 2. Non-grease laden sources such as, but not limited to, hand-wash sinks, toilets, urinals, and stormwater, shall not be connected to a grease removal device.
 3. No dishwasher shall be connected to a grease trap.
 4. Discharge of wastewater with temperatures in excess of 140° F (60° C) into any grease trap is prohibited.
 5. Garbage disposals (food grinders) shall be prohibited at all New Food Service Establishments. Existing Food Service Establishments shall remove all garbage disposals when they remodel or within one hundred eighty (180) days from receiving a notice from YNP to remove its garbage disposal(s) based on the Utilities Manager's finding that the FSE at any time caused or contributed to an SSO.

YOSEMITE NATIONAL PARK UTILITIES BRANCH

SEWER SYSTEM MANAGEMENT PLAN

EL PORTAL

SANITARY SEWER SYSTEM (CS 5SSO10735)

6. Direct disposal of any waste cooking oil into any drain or cleanout that is connected to the sewer system is prohibited.
 7. Introduction of any additive into a grease removal device or directly into the sewer system for the purpose of emulsifying FOG, biologically/chemically treating FOG for grease remediation, or as a supplement to any grease removal device maintenance is prohibited, unless specifically authorized in writing by YNP's Utilities Manager. Discharge of any waste which has been removed from a grease removal device into the sewer system is prohibited.
- E. FOG Wastewater Discharge Contract Provision Required: All Food Service Establishments shall sign a FOG Wastewater Discharge Contract Provision. Nothing in the contract provision is intended to relieve the Food Service Establishment operated by the Concessionaire of any state, or federal regulation. The contract provision will be reviewed between the YNP Superintendent and the Concessionaire.
- F. Contract Provision Requirements: FOG Wastewater Discharge Contract Provisions shall include the following information:
1. Name, address, telephone number, description of the Food Service Establishment operated by the Concessionaire and service activities.
 2. Name of any and all managers of the Food Service Establishment operated by the Concessionaire where the Food Service Establishment is located.
 3. Floor, site and plumbing plans showing detailed sewer connections and grease removal devices.
 4. Specifications of all grease removal devices.
 5. Operational statement of FSE.
 6. Any other information as may be specified in the Contract Provision.
- G. FOG Wastewater Discharge Contract Provision Conditions:
1. FOG Wastewater Discharge Contract Provision must contain the following:
 - a. A statement that indicates the wastewater discharge contract provision duration.
 - b. A statement that the wastewater discharge contract provision is nontransferable.
 - c. A statement of applicable civil and criminal penalties for violation of contract provisions related to FOG.

YOSEMITE NATIONAL PARK UTILITIES BRANCH

SEWER SYSTEM MANAGEMENT PLAN

EL PORTAL

SANITARY SEWER SYSTEM (CS 5SSO10735)

2. FOG Wastewater Discharge contract provision may contain the following conditions or limits if found necessary to meet the intent of this Agreement by the YNP:
 - a. Limits on discharge of FOG and other pollutants.
 - b. Requirements to install, operate, and maintain adequate pretreatment devices including grease removal devices.
 - c. Requirements for proper operation and maintenance of all pretreatment devices.
 - d. Grease removal device maintenance frequency and schedule.
 - e. Requirements for implementing, maintaining, and reporting on the status of Best Management Practices.
 - f. Requirements for maintaining and submitting logs and records, including waste hauling records and manifests and to have such records available for inspection.
 - g. Requirements to self-monitor.
 - h. Additional requirements as may be determined to be reasonably appropriate by the YNP or as specified by other Regulatory Agencies to protect the collection system.
 - i. Other terms and conditions, which may be reasonably applicable to ensure compliance with the FOG Control Supplement.
- H. FOG Wastewater Discharge contract provision Modifications: FOG Wastewater Discharge contract provision modifications are subject to and are consistent with the terms, requirements and policies in this section.
- I. Best Management Practices: All Food Service Establishments shall implement Best Management Practices (BMPs) in an effort to minimize the discharge of FOG to the sewer system, including, but not limited to, the following, as applicable:
 1. Installation of Drain Screens. Drain screens shall be installed on all drainage pipes in food preparation areas.
 2. Segregation and Collection of Waste Cooking Oil. All waste cooking oil shall be collected and stored properly in recycling receptacles such as barrels or drums. Such recycling receptacles shall be maintained properly to insure that they do not leak. Licensed waste haulers or an approved recycling facility must be used to dispose of waste cooking oil.

YOSEMITE NATIONAL PARK UTILITIES BRANCH

SEWER SYSTEM MANAGEMENT PLAN

EL PORTAL

SANITARY SEWER SYSTEM (CS 5SSO10735)

3. Disposal of Food Waste. All food waste should be disposed of directly into the trash or garbage and not into sinks and shall be disposed of in a manner that will ensure against leakage in the trash container or anywhere else.
 4. Employee Training. Employees of the Food Service Establishment shall be trained by ownership/management periodically as specified in the FOG wastewater discharge contract provision on the following subjects:
 - a. Dry-wiping pots, pans, dish ware and work areas before washing to remove grease.
 - b. Properly disposing food waste and solids in plastic bags prior to disposal in trash bins or containers to prevent leaking and odors.
 - c. The location and use of absorption products to clean under fryer baskets and other locations where grease may be spilled or dripped.
 - d. Properly disposing grease or oils from cooking equipment into a proper grease receptacle without spilling.
 - e. Training shall be documented along with employee signatures. Training records shall be available for review at any time by YNP Utilities Manager.
 5. Maintenance of Mechanical Exhaust Ventilation Filters. Filters shall be cleaned as frequently as necessary to be maintained in good operating condition. The wastewater generated from cleaning exhaust filters shall be disposed of properly.
 6. Kitchen Signage. Best management and waste minimization practices shall be posted conspicuously in the food preparation and dishwashing areas at all times.
- J. FOG Pretreatment Required for New and Existing Food Service Establishments: Food Service Establishments are required to install, operate and maintain an approved type and adequately sized grease interceptor necessary to maintain compliance with the objectives of this section, subject only to the variance and waiver provisions and other exceptions of this section. The grease interceptor shall be adequate to separate and remove FOG contained in wastewater discharges from FSE's prior to discharge to the sewer system. Fixtures, equipment, and drain lines located in the food preparation and cleanup areas of FSE's that are sources of FOG discharges shall be connected to the grease interceptor.

YOSEMITE NATIONAL PARK UTILITIES BRANCH

SEWER SYSTEM MANAGEMENT PLAN

EL PORTAL

SANITARY SEWER SYSTEM (CS 5SSO10735)

1. New FSE's shall include and install grease interceptors prior to commencing discharges of wastewater to the sewer system.
 2. Existing FSE's shall install grease interceptors in any of the following circumstances:
 - a. When the FSE changes ownership;
 - b. When any change in operation results in or has the potential to result in the increase of the amount of FOG generated and/or discharged by FSE in an amount that alone or collectively causes or creates a potential SSO to occur;
 - c. When it is determined by the YNP Utilities Manager that the FSE caused or contributed to grease-related blockages in the sewer system, has sewer laterals connected to hot spots, or has been determined to contribute significant FOG to the sewer system, based on inspection and sampling;
 - d. During a remodel;
 - e. Any other time the YNP Utilities Manager reasonably determines that installation of a grease interceptor is necessary to avoid an adverse impact to the sewer system.
 3. Any Existing FSE that receives a notice from the YNP Utilities Manager to install a grease interceptor must install the interceptor within 30 days unless otherwise required by the YNP Utilities Manager.
- K. Variance of Grease Interceptor Requirement: Notwithstanding any other provision in this section, an existing FSE may obtain a variance, at the YNP Utilities Manager discretion, from the grease interceptor requirement to allow alternative pretreatment technology that is equally effective in controlling the FOG discharge in lieu of a grease interceptor. One such type of alternative pretreatment technology is a grease trap. Consideration of granting the variance will be based on the following:
1. There is insufficient space for installation and/or maintenance of a grease interceptor.
 2. There is inadequate slope for gravity flow between kitchen plumbing fixtures and the grease interceptor and/or between the grease interceptor and the private collection line or the public sewer.

YOSEMITE NATIONAL PARK UTILITIES BRANCH

SEWER SYSTEM MANAGEMENT PLAN

EL PORTAL

SANITARY SEWER SYSTEM (CS 5SSO10735)

3. The FSE can demonstrate, to the satisfaction of the YNP Utilities Manager, that the alternative pretreatment technology is equivalent or better than a grease interceptor in controlling FOG. In addition, the FSE must be able to demonstrate, after installation of the proposed alternative pretreatment technology, its continued ability to effectively control FOG discharge.
 4. The variance may be rescinded if subsequent monitoring shows accumulation of FOG in the sewer lateral or the collection system downstream of the FSE's connection or if the FSE caused or contributed to a Sanitary Sewer Overflow. A grease interceptor must be installed within 30 days of the rescission of a variance.
- L. Waiver from Grease Removal Device Requirement: When granting a variance is not possible because the installation of a grease interceptor is not feasible and no equivalent alternative pretreatment can be implemented, an FSE may apply for and be granted a conditional waiver with the imposition of line maintenance cost recovery charges as established in the Master Fee Schedule. An FSE requesting a waiver must demonstrate that it has negligible FOG discharge and insignificant impact to the sewer system. Although a waiver may be granted, the YNP Utilities Manager may impose additional requirements including, but not limited to, the requirement to provide space and plumbing segregation for future installation of a grease interceptor.
- M. Cost Recovery: All costs incurred for cleaning the sewer line to remove FOG buildup caused or contributed to by an FSE shall be reimbursed to the park by the FSE. Factors for determining responsible parties for cost recovery charges include the FSEs that are discharging into the affected sewer line, the presence of grease removal devices or alternative pretreatment in the FSE, proper maintenance of grease removal devices by the FSE, implementation of BMPs, and any waivers or variances granted.
- N. Drawing Submittal Requirements: At the time of signing a FOG Wastewater Discharge Contract provision or upon request by the YNP:
1. FSEs will be required to submit copies of design and as-built facility site plans, mechanical and plumbing plans and details to show all sewer locations and connections. The documents shall be in a form acceptable to the YNP for review of existing grease control devices, monitoring facilities, metering

YOSEMITE NATIONAL PARK UTILITIES BRANCH

SEWER SYSTEM MANAGEMENT PLAN

EL PORTAL

SANITARY SEWER SYSTEM (CS 5SSO10735)

- facilities and operating procedures. The review of plans and procedures shall in no way relieve the FSE of the responsibility to modify the facilities or procedures in the future, as necessary to produce an acceptable discharge and to meet the requirements of this FOG Control Supplement.
2. FSE's will be required to submit a schematic drawing of the grease removal device or alternative pretreatment, piping and instrumentation diagram, and wastewater characterization report.
 3. At the Park's discretion, all drawings and/or reports will be required to be prepared by a California Registered Civil, Mechanical, Chemical, or Electrical Engineer.
- O. Grease Interceptor Requirements: Any FSE that is required to provide FOG pretreatment shall install operate and maintain an approved type and properly sized grease interceptor, or other grease removal device authorized under an approved variance, necessary to maintain compliance with the purpose of the FOG Control Supplement.
1. Approved grease interceptor sizing and installation shall conform to the latest approved edition of the California Uniform Plumbing Code.
 2. Grease interceptors shall be constructed in accordance with the design approved by the Park and shall have a minimum of two compartments with fittings designed for grease retention.
 3. Grease interceptors shall be installed at a location where it shall be at all times easily accessible for inspection, cleaning and removal of accumulated grease.
 - a. Grease interceptors may not be installed in any part of the building where food is handled.
 - b. If a location is not available on the site of the FSE, a street encroachment contract provision may be requested to authorize installation of a grease interceptor in a public access area such as the street or sidewalk area.
 - c. There will be no obstruction from landscaping or parked vehicles, with the exception of parked vehicles in a public access area as granted through a street encroachment contract provision.

YOSEMITE NATIONAL PARK UTILITIES BRANCH

SEWER SYSTEM MANAGEMENT PLAN

EL PORTAL

SANITARY SEWER SYSTEM (CS 5SSO10735)

4. Access manholes, with a minimum diameter of twenty-four (24) inches, shall be provided over each grease interceptor chamber and sanitary tee. The manholes shall also have readily removable covers to facilitate inspection, grease removal and wastewater sampling activities.
 5. The original design of the grease interceptor shall not be modified unless the manufacturer recommends the modification in writing.
 - a. Any modification will be at the expense of the Concessionaire operating the Food Service Establishment.
 - b. YNP is not liable for any non-compliance as a result of any modification.
- P. Grease Interceptor Maintenance Requirements: Grease interceptors shall be maintained in efficient operating condition by periodic complete removal of all contents of the devices including wastewater, accumulated FOG, floating materials, sludge and solids.
1. No FOG that has accumulated in a grease interceptor shall be allowed to pass into any sewer lateral, sewer system, storm drain, or Park right of way during maintenance activities.
 2. FSE's that are located in an area that is considered to be a hot spot will be required to submit data and information necessary to establish a maintenance frequency for their grease interceptor.
 3. The maintenance frequency for all FSE's with a grease interceptor shall be determined in one of the following methods:
 - a. Grease interceptors shall be fully pumped out and cleaned at a frequency such that the combined FOG and solids accumulation does not exceed the 25% Rule. Regardless, the interval between cleaning shall not exceed six (6) months. The 25% rule is defined as, "When the FOG layer and food solids layer are 25% or greater than the depth of the tank then the tank needs to be pumped."²⁸
 - b. The operator of a FSE may submit a request to the Park asking for a change in the maintenance frequency at any time. The FSE has the burden of responsibility to prove that the change reflects actual operating conditions based on the average FOG accumulation over time, and meets the requirements of the 25% Rule. The FSE's must also show that it is in full compliance with the conditions of its FOG Wastewater

28 http://www.swrcb.ca.gov/rwqcb7/water_issues/programs/pretreatment/docs/intro_fog_inspections.pdf

YOSEMITE NATIONAL PARK UTILITIES BRANCH

SEWER SYSTEM MANAGEMENT PLAN

EL PORTAL

SANITARY SEWER SYSTEM (CS 5SSO10735)

Discharge Contract provision and this section. Upon approval by the Park, the FOG Wastewater Discharge Contract provision will be modified accordingly to reflect the change in maintenance frequency.

- c. If the grease interceptor contains, at any time, FOG and solids accumulation that exceeds the 25% Rule, the FSE shall be required to have the grease interceptor serviced immediately so that all FOG, sludge and other materials are completely removed from the interceptor. If necessary, the FSE may be required to increase the maintenance frequency of the grease interceptor from its current frequency.
 4. Wastewater, accumulated FOG, floating materials, sludge, solids, and other materials removed from the grease interceptor shall be disposed offsite properly by licensed waste haulers in accordance with federal, state, county and contract agreement.
- Q. Grease Trap Requirements: Grease traps may be authorized by the Park through a variance under Subsection (k) with the following conditions:
1. Grease traps shall be installed in waste lines leading from drains, sinks and other fixtures or equipment where grease may be introduced into the sewer system in quantities that can cause blockage.
 2. Grease traps shall be properly sized and installed in accordance with the latest approved edition of the California Uniform Plumbing Code.
 3. The original design of the grease trap shall not be modified unless the manufacturer recommends the modification in writing.
 - a. Any modification will be at the FSE's expense.
 - b. The Park is not liable for any non-compliance as a result of any modification.
 4. Grease traps shall be maintained in efficient operating conditions by removing accumulated grease. The interval between cleaning will be established by the Park, but shall not exceed two (2) weeks. Baffles shall be removed and cleaned during the maintenance process, when applicable.
 5. Grease traps shall be kept free of all food residues and any FOG waste removed during the cleaning and scraping process.
 6. Grease traps shall be inspected periodically to check for leaking seams and pipes and for effective operation of the baffles and flow regulating devices.
 7. Grease traps and their baffles shall be maintained free of all caked on FOG and waste.

YOSEMITE NATIONAL PARK UTILITIES BRANCH

SEWER SYSTEM MANAGEMENT PLAN

EL PORTAL

SANITARY SEWER SYSTEM (CS 5SSO10735)

8. Dishwashers and food waste disposal units shall not be connected to or discharged into any grease trap.
9. The temperature of any water entering a grease trap shall not exceed 140° F (60° C).

R. Monitoring Requirements:

1. The Park may require, through the FOG Wastewater Discharge Contract provision or at any time, an FSE to construct and maintain in proper operating condition, at the FSE's sole expense, flow monitoring, constituent monitoring, and/or sampling devices.
2. The location of monitoring or metering devices shall be subject to approval by the Park.
3. At all times, FSEs shall provide immediate, clear, safe and uninterrupted access to YNP USRO staff to all monitoring and metering devices.
4. FSEs may be required by the Park to submit waste analysis plans, contingency plans, and meet other necessary requirements to ensure proper operation and maintenance of any grease removal device and compliance with this section, (s) Record Keeping Requirements. FSEs shall keep all records, including manifests, receipts and invoices of all cleaning and maintenance of grease removal devices. All records shall be made available to YNP Utilities Management upon request. In addition to the above mentioned documents, records include logbooks of maintenance activity, BMPs and employee training, sampling data, spill reports, line cleaning reports, and any other information deemed appropriate by the Park to ensure compliance with the FOG Control Supplement and this section.

YOSEMITE NATIONAL PARK UTILITIES BRANCH

SEWER SYSTEM MANAGEMENT PLAN

EL PORTAL

SANITARY SEWER SYSTEM (CS 5SSO10735)

RIGHTS OF INSPECTION AND SAMPLING

- A. Rights of Entry: The Park shall have the right to enter premises of any user to determine whether the user is complying with all requirements of the contract and any wastewater discharge contract provision or order issued hereunder. Concessionaires owners or occupants of premises where wastewater is created or discharged shall allow the EPA, the State, or Park's representative ready access at all reasonable times to all parts of the premises for the purpose of inspection, sampling or record examination, or in performance of any of their duties.
- B. Rights to Monitor: Yosemite NPS shall have the right to set up on the user's property such devices as are necessary to conduct sampling inspections, compliance monitoring and/or metering operations. Yosemite NPS shall also have the right to conduct unbeknown surveillance monitoring of the user's wastewater discharge offsite of the facility premises, taking into consideration all potential contributors to the same wastestream, and enforcing all applicable provisions of this article as necessary. Nothing provided herein is intended to limit the rights of the Park in any way in regards to its use and control of the Park's facilities.
- C. Access to Facilities: Where a user has security measures in force which would require proper identification and clearance before entry onto the premises, the user shall make necessary arrangements with his security staff so that, upon presentation of suitable identification, personnel from the Yosemite NPS will be contract provisioned to enter without delay for purposes of performing their specific responsibilities.
- D. Obstructions to Access: Any temporary or permanent obstruction to safe and easy access to the facility to be inspected and/or sampled or monitored shall be promptly removed by the user at the written or verbal request of the Yosemite NPS and shall not be replaced. The costs of clearing such access shall be born by the user.

YOSEMITE NATIONAL PARK UTILITIES BRANCH

SEWER SYSTEM MANAGEMENT PLAN

EL PORTAL

SANITARY SEWER SYSTEM (CS 5SSO10735)

- E. Access Delayed or Refused: Unreasonable delays in allowing the Yosemite NPS access to a user's premises or refusing access to the Yosemite NPS to a user's premises shall be a violation of this contract.

- F. Administrative Inspection Warrant: If an occupant, concessionaire or agent refuses permission to enter, or inspect, the Yosemite NPS may seek further legal action under law and or remedies pursuant to the contract, to perform the duties imposed upon the Yosemite NPS.

YOSEMITE NATIONAL PARK UTILITIES BRANCH

SEWER SYSTEM MANAGEMENT PLAN EL PORTAL SANITARY SEWER SYSTEM (CS 5SSO10735)

This page left intentionally blank.

YOSEMITE NATIONAL PARK UTILITIES BRANCH

SEWER SYSTEM MANAGEMENT PLAN EL PORTAL SANITARY SEWER SYSTEM (CS 5SSO10735)

APPENDIX B: UTILITY RATE COMPUTATION SUMMARY

YOSEMITE NATIONAL PARK UTILITIES BRANCH

SEWER SYSTEM MANAGEMENT PLAN

EL PORTAL

SANITARY SEWER SYSTEM (CS 5SSO10735)

UTILITY RATE COMPUTATION SUMMARY - El Portal

PREPARER'S NAME:

PARK NAME: Yosemite National Park

DATE PREPARED: 6/1/2013

UTILITY: Sewer

DURATION OF RATE: Jan 1-Dec 31, 2013

TOTAL ANNUAL UNITS PRODUCED: xxxx

UNIT OF MEASURE (ie - 1000's gallons, tons, kWh) xxxx

OPERATIONS AND MAINTENANCE

1 LABOR	\$233,492.31
2 LABOR (TRAVEL)	\$0.00
3 15% ADMINISTRATIVE OVERHEAD	\$35,023.79
4 PARTS, MATERIALS, SUPPLIES, TOOLS, VEHICLE TOOL COSTS	\$4,500.00
5 FEES AND CONTRACTED SERVICES	\$2,669.74
6 ENERGY COSTS (INCLUDING FUEL COSTS BUT NO VEHICLE FUEL)	\$51,000.00
7 TRAINING	\$2,760.00
8 TOTAL OF LINES 1 THROUGH 7	\$329,445.84

9 NUMBER OF UNITS PRODUCED	xxxx
10 O&M RATE (DOLLARS PER UNIT OF MEASURE) LINE 8 DIVIDED BY LINE 9) per unit	per unit

CYCLIC MAINTENANCE (Amortized portion)

11 COMPONENT RENEWAL Yearly Cyclic Maintenance (From Cyclic Maintenance Amortization Schedule)	\$1,499.12
12 COMPONENT RENEWAL RATE (LINE 11 DIVIDED BY LINE 9) per unit	per unit

RECAPITALIZATION/NEW CAPITAL

13 (FROM RECAPITALIZATION/NEW CAPITAL/FUTURE CAPITAL AMORTIZATION SCHEDULE)	\$34,706.68
14 CAPITAL RECOVERY RATE (LINE 13 DIVIDED BY LINE 9) per unit	per unit

UTILITY RATE

19 TOTAL RATE ((LINE 8 + LINE 11 + LINE 13) DIVIDED BY LINE 9) per unit	per unit
---	----------