



BULLETIN

Volume 7: No. 3 Cultural Resources Management • A National Park Service Technical Bulletin October 1984

Strategic Goals For Cultural Resources

The following cultural resources goals were approved by Director Dickenson in July, 1984. What follows is an excerpt from his cover memorandum addressed to the Field Directorate, as well as the goals themselves.

The Editor

The goals in this paper have been drawn from hundreds of contacts, formal and informal, with field, regional, and WASO people. The intent is to guide, rather than to instruct. This is not a plan I am asking

you to execute, but a direction I am asking you to pursue. For convenience only, the goals are grouped in two broad categories. *Cultural Resource Management* refers to our responsibilities to manage cultural resources that are in the National Park System. *National Register Programs* refers to our broader responsibility to guide and encourage cultural resource programs in other Federal agencies, States, local governments and the private sector. No ex-

clusive jurisdiction is intended by the two categories, and no order of priority is intended by the order in which goals are presented.

Our cultural resources mission is extremely diverse, so not every goal will be relevant to every employee. In the final analysis, however, we are one Service with one mission, and I hope every reader will consider these goals in that sense. I would like the

continued on page 2

Keane Wonder Mine Structure Stabilization Project

Edwin L. Rothfuss

Two PRIP program packages totaling \$152,000 were approved for FY 1983 to reduce hazards to the public at the historic Keane Wonder Mine. The hazards consisted of failing upper and lower terminal and breakover tower timber structures supporting the track cables of the 4700-foot-long aerial tramway on which the ore had been lowered 1,600 feet from the mine to the mill at the base of the mountain, and the shafts, adits and other mine openings. The mine and mill property had been acquired by the National Park Service (NPS) in 1972.

The Keane Wonder Mine operated from 1903, shortly after discovery of the ore body, to 1914, and was one of the few Death Valley gold properties to produce a profit. Sporadic, unsuccessful attempts to restart operations were made until the early 1940s. During the period, gold valued at \$1,100,000 was produced.

The park superintendent obtained the services of the Denver Service



continued on page 2

Strategic Goals . . .

continued from page 1

paper to be distributed broadly within the Service—please note that interest in these goals should not be confined to cultural resource staffs nor to cultural units of the system. I hope the paper will be used in hundreds of discussions in which organizational components of the Service decide upon their own goals and objectives and in which employees develop their individual annual performance standards. Above all, I want people to apply the goals within the context of their circumstances, so the broader strategy can benefit from the creative minds of several thousand individuals.

Russell E. Dickenson

CULTURAL RESOURCE MANAGEMENT (within the National Park System)

1. *Strengthen the Servicewide consensus on behalf of cultural resources.*
The National Park Service is the nation's lead agency in cultural resource management. Caring for cultural resources is not the isolated responsibility of a few highly-trained specialists but rather the obligation of every employee whose duties bring him or her into contact with cultural resources. Managers should encourage such employees to think of themselves as cultural resource advocates and to pursue self-improvement in CRM skills.
2. *Upgrade the use of planning in the management of cultural resources on three broad fronts.*
 - A. Resource Management Plans must become more reliable bases for decisions to be made about cultural resources. Improvements must be developed in Cultural Resource Management Planning methodologies.
 - B. Plans that provide detailed guidance for dealing with cultural resources (e.g. Archeological Overviews and Assessments, Collection Management Plans, Historic Structures Reports, Historic Resources Studies, and Historic Structures Preservation Guides) must be practical and economical, compatible with the significance of the resources, useful to projects that will affect the resources, and prepared well in advance of such projects.
 - C. All States and many local governments have historic preservation planning processes. Both because of the nature of the cultural resources the NPS manages and because outside forces

can affect NPS interests, these planning processes are important to us. Managers are asked to participate actively in them.

3. *Expand use of the private economy to preserve cultural resources in the NPS.*
The new authority to lease historic properties owned by the NPS, especially when coupled with the Historic Preservation Tax Incentives program, provides an unprecedented opportunity to carry out badly needed restoration and rehabilitation projects. It is important to make maximum use of this opportunity. It is equally important to achieve good results for the historic properties and the parks in which they are located.
4. *Clarify and improve guidance to the field concerning cultural resources.*
Attention will be focused on, but not limited to, revisions of NPS-28, the Cultural Resources Management Guideline. Traditionally high NPS standards of quality are to be maintained, but a better result will be ob-

tained by making the guidance easier to understand and to apply in the broader context of the NPS mission.

5. *Achieve full accountability.*
We must know the number, the nature, the location, and the use of the historic and prehistoric buildings, sites, structures, and objects that compose our cultural resources. This includes completion of the National Catalog of Museum Objects, completion and functional improvement of the List of Classified Structures and the Cultural Sites Inventory, and listing of appropriate properties in the National Register of Historic Places.
6. *Share technical information about cultural resources.*
The cultural resource projects undertaken by the NPS are, of necessity, laboratories wherein NPS experts regularly encounter and resolve new technical problems. Simple and economical systems must be implemented, by which the technical lessons learned in this process can be shared with others who need the in-

Keane Wonder . . .

continued from page 1

Center, which, with historical support of the Western Regional Office, formulated plans to reduce hazards at the mine. With failure of the tramway structure eminent, emphasis and most of the funds were directed toward its stabilization. This consisted of work at the upper terminals, the lower terminal, and a critical breakover station between terminals.

The upper terminal required the removal of a cable load from the support structure by means of two steel braces. These braces were fitted with steel cradles to hold the cable runners. Short sections of 7/8" stainless steel cables were clamped to the cables and their ground anchor to assure continued anchorage. The breakover station, on a ridge 1,200 feet from the upper terminal, was reinforced with steel beams to prevent it from being pulled apart by cable tension.

The cable load on the lower tram terminal was shifted by placing a steel beam system from the structure, where the cables had slipped off their pulleys and torn into the wooden floor planking, to thrust plates set in the hillside behind the structure. One of the suspended counterbalances, a

large timber box filled with rock, that maintains tension in the track cables was blocked up. A retaining wall of earth and wood, 13' high and 30' wide was installed at the lower terminal to prevent erosion of a bank on which footings for part of the structure are secured.

Only three mine openings, all vertical shafts located near the millsite, were closed during the mid-March to April time period allotted by Denver. They closed the shafts with a 6' X 6' mesh net made of 3/16" galvanized steel cable placed over the shafts. The safety nets were secured to the dumps by means of ground screw anchors.

Twelve additional hazardous mine openings remain to be closed consisting of four shafts, three adits and five large underground workings (stopes and glory holes) open to the surface. The Death Valley Mining Division staff which has coordinated the work to date, independently, plans to close at least two of these openings by the end of the fiscal year, and is assembling the materials and equipment to close others in the future.

Edwin L. Rothfuss is Superintendent, Death Valley National Monument.

formation. A partial model exists in the publications known as "Conservation-O-Gram" and "Preservation Briefs."

7. *Build basic expertise in dealing with cultural resources.*
NPS cultural resources must serve as classrooms as well as laboratories in order to produce the beneficial by-product of increased capability. We must develop on-the-job training programs, including but not limited to "hand-on" training for maintenance staffs in appropriate field units. Cultural resource training must also be increased for park managers, resource management specialists, interpreters, and rangers. Parks, regions, centers, and WASO must continually improve the expertise of their specialized cultural resource staffs.
8. *Improve the Cultural Resource Management System.*
We must improve our ability to program cultural resource treatment projects according to the need and the significance of the resources. Such treatments must be programmed in logical sequence with the end goal being cyclic maintenance—a situation in which the need for "projects" would be reduced to a minimum. The present NPS planning system is adequate for this purpose, but it has not been fully employed with regard to cultural resources.
9. *Document the primary historic and prehistoric structures of the National Park System.*
All of the National Park Service's primary historic and prehistoric structures should be documented to Standards of the Historic American Buildings Survey/Historic American Engineering Record (HABS/HAER). Copies of the records should be deposited in the HABS/HAER collections in the Library of Congress.

NATIONAL REGISTER PROGRAMS (Beyond the National Park System)

1. *Institutionalize the use of the Secretary of the Interior's Archeology and Historic Preservation Standards and Guidelines.*
Federal agencies and states will be encouraged and assisted to use the Secretary's standards and guidelines in carrying out their historic preservation responsibilities for Planning, Identification, Evaluation, Registration, and Documentation of Cultural Resources.

continued on page 6

A Practical Deployment Array For The Geohm 3 Soil Resistivity Meter

John E. Ehrnehard, William P. Athens, Richard E. Johnson

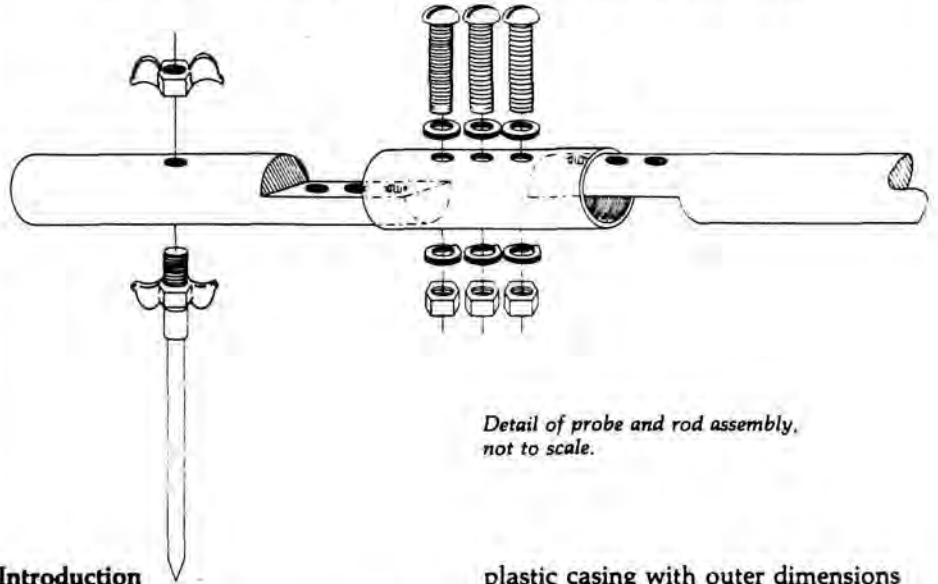

Detail of probe and rod assembly, not to scale.

Introduction

The Southeast Archeological Center designed and constructed a transport system providing a moderately inexpensive way to transport resistivity meters and probes, thereby reducing repositioning time and increasing recording time.

The use of soil resistivity surveying in archeology has become a widely used method of remote sensing, one used extensively by the Southeast Archeological Center, National Park Service. The popularity of this technique may be attributed to the low cost of the equipment, low maintenance requirements, and the simplicity of technique and operation. The chief disadvantage has been the time involved in moving one or more of the probes after each reading. This article describes a system constructed by the Center in 1981. A moderately inexpensive, accurate device for transporting the resistivity meter and probes, it reduced the repositioning time and increased the period spent taking readings. The system also reduced another common complaint associated with resistivity surveying—the backache.

Equipment

The resistivity meter used in this system was the Gossen Geohm 3¹ selected because of operational ease. The Geohm 3 is housed in a Noryl-

plastic casing with outer dimensions of 7.25 × 6.25 × 2.5 inches, and weighs approximately 2.5 pounds (including batteries). The instrument has *automatic* selection of ranges up to 200 kOhm, and, therefore, needs no adjustment. The measuring leads can be quickly connected because of the combined clamp-plug-in sockets. Clear reading is possible on the corrected digital display. Accuracy is 0.01 Ohm.

Transport System

A light-weight rod of acetal resin thermoplastic, commercially known as 'Delrin'², carries the resistivity meter and probes. 'Delrin' has physical properties not shared by other plastics. Attributes include: (1) high mechanical strength and rigidity, (2) fatigue endurance, (3) excellent resistance to moisture, solvents and other neutral chemicals, (4) ease of fabrication, (5) high resistance to repeated impacts, (6) good electrical insulating properties, (7) resiliency and (8) the ability to withstand extreme variations in temperature.

Probes

Eighteen-inch long probes were manufactured from 5/8" diameter copper rods, and threaded to accept wing nut fasteners. Stainless steel, or other high quality electrical conduc-

continued on page 5

Guns Over The Potomac

Marilyn W. Nickels

Fort Foote is an earthwork fortification constructed during the Civil War to protect Washington from river encroachment by Confederate forces. It stands on a high bluff overlooking the Potomac River on the Maryland side, approximately eight miles south of the capitol. The largest of 68 forts and batteries surrounding the city during the war, Fort Foote remains largely unknown, and, at best, puzzling to those who are able to find it. In addition to the large embankments which compose the fort, brick and concrete magazines occupy one end. Behind the main traverse are five large empty gun emplacements. Until recently, two large dismantled guns occupied the rear of the fort. Next to them lay the broken remains of a gun carriage.

How to manage this historic material became a primary concern of the park. It decided to return the guns to their original positions, despite the complications. Each 15-inch Rodman cannon weighed 25 tons. The fort received them in 1863 and 1864, mounted them during the war, and removed them to the rear of the fort during its reconstruction in the early 1870s. Despite the length of time they layed on the ground, they remained fairly indestructible. Other historic fabric was not so trustworthy.

At this point, Jack Longworth, a civil engineer in the regional office, suggested we examine the large circular gun mounts to determine their ability to support the cannons' weight. After exposing the mount foundations, we determined that the granite, concrete, and iron structures remained solid, despite a century of exposure to the elements.

Next, we constructed iron and steel carriages to mount the guns, the most expensive stage of the project due to the casting of numerous wheels and other guns parts. Bill Brown of the Harpers Ferry Center had helped construct Rodman gun carriages for Fort Moultrie during the bicentennial commemoration. He became our "in-house" consultant. Fortunately, the molds from the cast parts of those carriages had been retained by the Harpers Ferry Center.

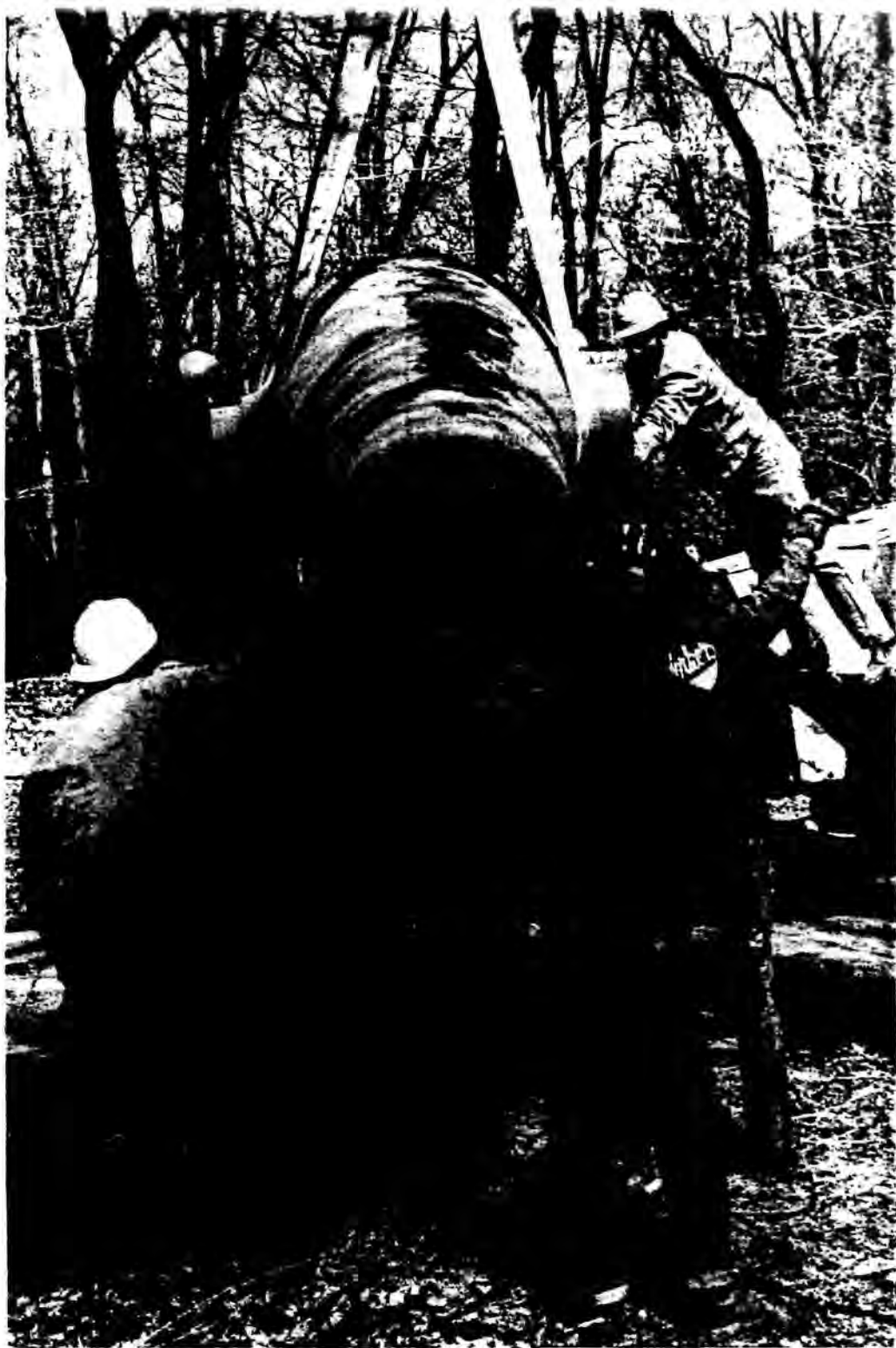

Setting the center pintle Rodman in place. Ft. Foote MD.

(Photo by Don Steiner)

This resolved only half of our problems, however. We needed *two* kinds of carriages: a front-pintle, for which we now had the molds, and a center pintle, for which we had nothing. We considered mounting only one gun, until we looked carefully at the old carriage pieces lying on the ground. Here were the fragments of a center-pintle carriage. Were they usable? Could missing

parts be cast from the extant ones? Two local companies offered assistance; Frederick Iron and Steel of Frederick, Maryland, which had cast the parts for the Fort Moultrie project, picked up the carriage parts and conveyed them to Hagerstown, Maryland. Here Danzer Metal Works, a steel fabricating firm, examined the old carriage. Despite a century of exposure and aging, the parts remained

in surprisingly good condition, a credit to the craftsmanship of the old material.

With these additional resources, the park proceeded to build two carriages. The center-pintle was a restoration, using the side plates in their entirety, set on a new chassis and a combination of old and new wheels. The front-pintle was a reproduction, built much like the ones now at Fort Moultrie.

On February 22, 1984, Frederick Iron and Steel delivered the carriages to Fort Foote. Although it was a proud day for the park, the real challenge was just beginning. The new carriages, weighing five tons a piece, and the gun barrels, weighing 25 tons each, had to be moved back onto their emplacements within the fort.

Between the guns and their emplacements were fragile earthworks, either earth embankments which could not be traversed or concrete and brick tunneling which would collapse under the weight of heavy equipment. To add to the challenge, the low-lying roadways of the fort become swamplike in rainy weather. This year was no exception. An early thaw in February, and spring rains in March resulted in poor ground conditions for the remainder of the project.

United Rigging and Hauling of Beltsville, Maryland accepted the challenge. Unable to use a crane large enough to boom the tubes directly to the emplacements, they lined the roadway into the fort with large wooden rafts, then brought in their 35-ton and 90-ton cranes. They built a bridge over the historic tunnels, providing an acceptable pathway from the guns to the center-pintle mount.

The 35-ton crane drove across the bridge to help the larger crane move the cannon and carriage. Once near the emplacement, the smaller crane lifted them up and set them in place.

Next, the small crane moved via more wooden roadway across the central traverse of the fort to the second emplacement. finally, at dusk they lifted the second gun onto its carriage. One hundred years had overlooked the Potomac River. "A year ago I never dreamed this would happen," commented Chief Historian, Ed Bearss. It was a satisfying moment for all involved. ©

Marilyn W. Nickels is a Historian for National Capital Parks-East.

Geohm . . .

continued from page 3

tors could also have been used. In fact, stainless steel appears better than copper, in retrospect, because of its ease in machining and its superior resistance to the pressure applied when the probes are inserted in the ground.

System Design

Design specifications called for the transport mechanism to be in a fixed four-point Wenner configuration. Probes were spaced at one meter intervals. Other specifications required that the mechanism be small enough to be hand carried as personal luggage on commercial aircraft. The thermoplastic rod was cut into three pieces for this purpose. Once divided, couplings were prepared for the joints, and holes were drilled in their proper locations for each of the four probes. We point out that the Wenner configuration is not the only or necessarily the best way of positioning the probes; it is the one we have found effective in our studies. Modifications of the rod can be made to provide for a closer interval between the probes for re-measurement purposes.

A simple wooden box with interior padding housed the resistivity meter. The box and meter were attached to the rod; appropriate lengths of lead wire were prepared with alligator

clamps and banana plugs for quick connection between the probes and the meter.

Once constructed, the total weight, including carrying case, did not exceed 26 pounds. Breakdown length was 52 inches, and the equipment could be assembled in less than fifteen minutes. Since its construction in 1981, the transport device has undergone extensive use, required little maintenance, and shows no appreciable wear on any of its strategic components.

Materials

A list of the materials and their cost (as of 11/20/83) for developing such a system appears below. Total cost, including the meter and machining costs, runs approximately \$900.

Parts List

1	Gossen Geohm 3 Meter	\$400.00
13'	Delrin rod (1½" diameter)	215.00
12'	Copper rod, 5/8" diameter (enough for 2 sets). Stainless steel may be purchased at a lower cost.	150.00
4'	1½" diameter PVC tubing for outer sheath joint support (inner diameter).	5.00
9	2"×1/4" bolts with nuts and lock washers for joining Delrin sections.	12.00

continued on page 6

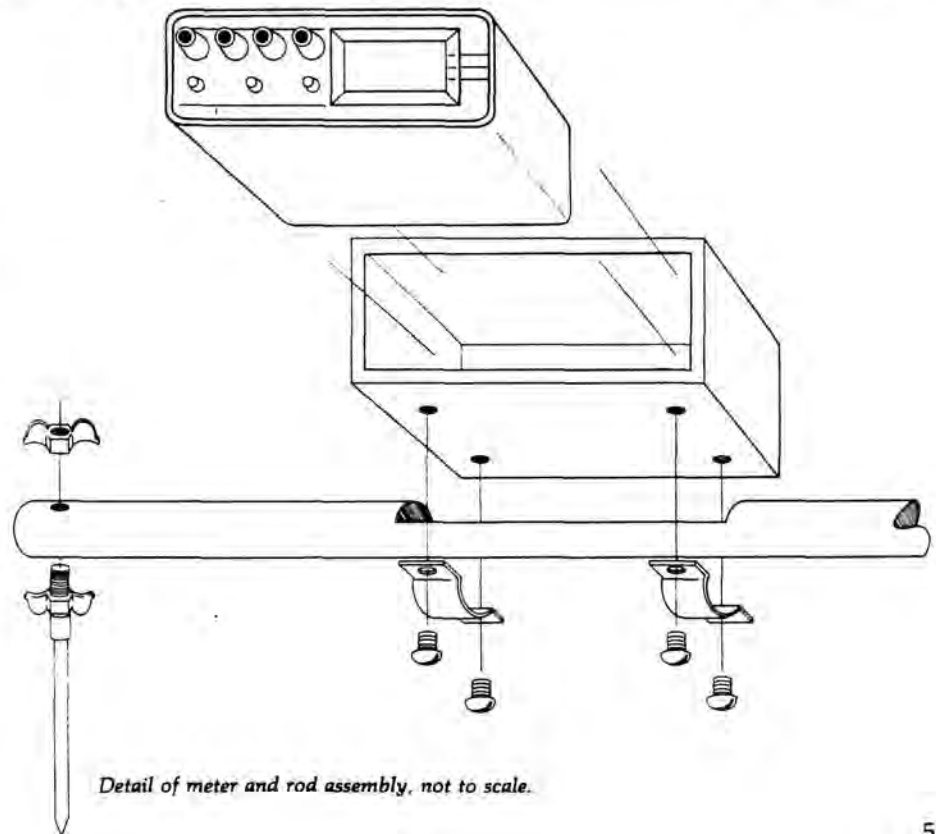

16	5/8" wing nuts to anchor probes to transport device	16.00
20	feet of 18 gauge electrical wire	3.00
4	linear feet of 1" x 12" lumber for meter housing	3.00
8	alkaline enercell "C" batteries (2 sets)	10.00
4	insulated test clips	2.00
4	banana plugs	2.00
	Machining costs	75.00
TOTAL COST		893.00

Footnotes

- ¹The Geohm 3 may be purchased from:
 GOSSEN GMBH
 Postfach 1780
 D-8520 Erlangen
 West Germany
- ²DELTRIN is a registered trademark of the DuPont Chemical Company. Use of this product should not be considered an endorsement.

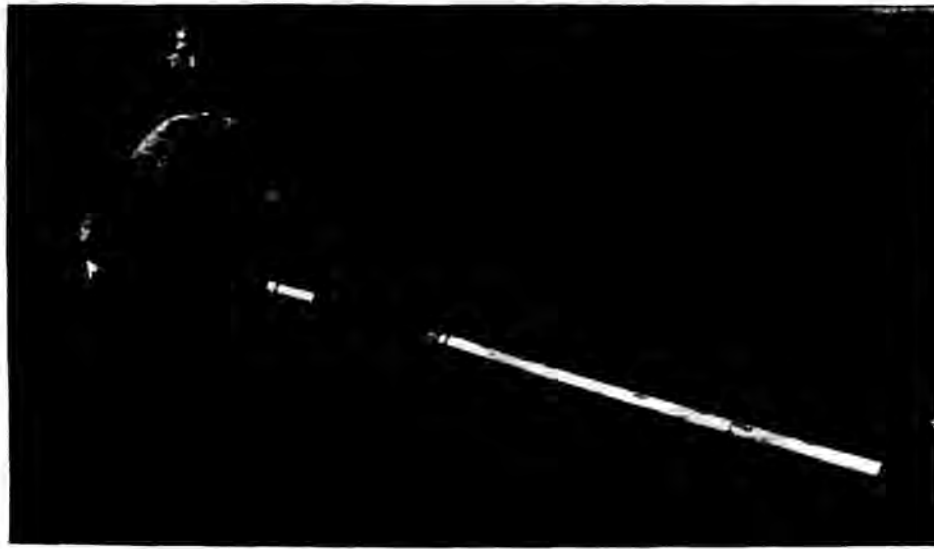

Strategic Goals . . . continued from page 3

2. *Further streamline and improve the National Register nomination and registration process.*
 The National Park Service will review and implement appropriate approaches for streamlining and improving the registration of properties in the National Register of Historic Places. The National Register data base will be automated to make it more readily available to Federal and State agencies and improve activities associated with preservation projects, planning, and research.
3. *Administration of the Historic Preservation Tax Incentive program.*
 The National Park Service will con-

Acknowledgements

The authors wish to express their thanks to Ms. Pam Houmère of the Florida State University, Department of Physics, for her time in machining the various components of the system.

John E. Ehrenhard was a research archeologist for the Southeast Archeological Center, National Park Service, in charge of the Inventory and Assessment/Remote Sensing section at the time this article was prepared. He is currently Chief, Archeological Services Branch, NPS in Atlanta.

William P. Athens serves as an archeology technician at the Southeast Archeological Center. His research interests include computer graphics and their applications to archeology. He is presently enrolled in the PhD program in Anthropology at the University of Pittsburgh.

Richard E. Johnson serves as an archeology technician at the Southeast Archeological Center. His duties include scientific illustration and archival research for the data base section of the Center.

ning, and to make available to the public quality documentation on historic structures of national significance. Emphasis will also be placed on developing advanced recording techniques and encouraging the donation of documentation to the HABS/HAER collection.

5. *Provide assistance to Federal agencies in the implementation of their archeological responsibilities.*
 The National Park Service will assist Federal agencies in the implementation of their archeological responsibilities in a manner that protects important archeological properties while placing the least burden on agency programs. The Service will also provide oversight and coordination to the Federal archeological effort. This includes developing a data base to prevent redundant projects, assisting agencies in a programmatic rather than a project by project fashion, and in developing guidance for the improvement of agency programs.
6. *Identification and protection of National Historic Landmarks.*
 The National Historic Landmark (NHL) program is being revived as an alternative means of identifying and protecting nationally significant properties without bringing them into the National Park System. Orderly study of broad themes of American history and prehistory will be the basic method of identifying and designating NHLs. The system for monitoring NHLs and reporting to Congress on their condition will be improved and expanded to include limited technical assistance to owners in order to reduce the number of threatened landmarks. The program will be better coordinated with interested professional groups.
7. *Continue to effectively administer funds appropriated for the Historic Preservation Fund assistance program.*
 Continued emphasis will be given to the apportionment process, fund administration, maintaining internal control, and monitoring the grantee program and program accomplishments.
8. *Maintain and improve the effectiveness of the working partnership with States, Federal agencies, local governments, the National Trust and others.*
 The Service must continue to coordinate carefully with its partners in the historic preservation field and to provide the standards, guidelines, and technical information necessary to sustain a sensible, cohesive, and effective national program. ©

NATIONAL CEMETERIES: Unique Cultural Resources Of The National Park Service

Daniel A. Brown

The National Park Service administers fourteen national cemeteries. Each is a unique historic entity, as well as an integral part of its park. The complex nature of cemetery operations on both a historic and emotional level creates problems not usually associated with other cultural resources. Cemetery maintenance is also labor intensive, requiring a higher standard of appearance than other park grounds. Such considerations create special needs in these days of tight administrative belts.

Historically, the national cemetery represents the last resting place of soldiers who participated in the military events the park com-

memorates. Some cemeteries contain the remains of individuals whose stature and fame excite popular and scholarly interest. Unique and valuable examples of historic art and architecture exist among the markers and monuments. Even the landscape plan and grounds arrangement reflect the taste and culture of the historic period.

National cemeteries occupy a position of high regard among Americans. The dignity and reverence to be accorded such areas was stated first at their inception in 1862, and restated in every legislative act and operational document since. Addi-

continued on page 9

STABILIZATION PROGRESSES ON HABRE-DE-VENTURE: Home of Eighteenth Century Aristocrat Thomas Stone

Cynthia Cosimano

Thomas Stone, the lawyer, revolutionary, and native Maryland son who served in Congress from 1775 to 1778, continues to be remembered at Habre-de-Venture, his Charles County, Maryland home. The house and grounds were established as a National Historic Site on November 10, 1978, chiefly to preserve his memory. The property became the responsibility of the National Park Service after a 1977 fire destroyed the center section of Georgian brick and charred the kitchen, leaving only the east wing, Thomas Stone's law office, intact. George D. Church, Superintendent of Washington's Birthplace; Henry Magaziner, Regional Historical Architect; and Mitchell Packet, Maintenance Foreman, have since initiated the successful stabilization of the damaged walls.

The site's Statement for Management requires that Habre-de-Venture reflect Thomas Stone's life as it relates to the emergence of a new nation, and as it provides invaluable insight into eighteenth century patterns of living. Thomas Stone purchased the 321.97 acres in 1770 with his wife's \$200 dowry. Although one of four Marylanders to sign the Declaration of Independence, he often favored minority opinion and continued to encourage reconciliation with Britain. As a lawyer in 1773, Stone prosecuted a Maryland legislator for refusing to pay a poll tax aiding the Anglican Church. He exemplified old-line attachments to the mother country at the start of the Revolutionary War. Stone died shortly after his wife's death in 1787 and is buried in the family plot at Habre-de-Venture.

This "grand Georgian mansion," as Maryland Senator Charles McC. Mathias Jr. has termed it, was built in 1771 and is architecturally significant, for it has five sections constructed in an arc, encompassing three distinct Southern Maryland styles: Georgian brick, clapboard and brick, and

continued on page 12



Stones River National Cemetery, Stones River National Battlefield, Murfreesboro, Tennessee.

The Integration of Law, Policy, and Technical Information in National Park Service Cultural Resource Programs

Jerry L. Rogers,

Every activity the National Park Service performs has origin in law, usually a statute enacted by the Congress and signed by the President.¹ In the Cultural Resource Programs, the NPS has developed a carefully integrated system to relate the decisions it makes on thousands of individual questions to its statutory authority, and also to assure that the best current technical practice can be used in resolving the questions. In fact, the system actually serves to generate new and better technical practice, and thereby improves the general quality of cultural resource projects and programs throughout the country. This system evolved in the Historic Rehabilitation Tax Incentive Program, and will be explained here in that context. The system allows effective administration with a minimum of regulation. It is being phased into operation in all NPS Cultural Resource Programs. In simplified form, the system may be described as a hierarchy of statute, regulation, standard, guideline, and technical information.

Federal income tax benefits are available under Sec. 46(a) and 48(g) of the Internal Revenue Code (which was amended by Sec. 212 of the Economic Recovery Tax Act of 1981—Public Law 97-34), to owners who carry out "certified rehabilitations" upon "certified historic structures." A "certified rehabilitation" is defined in the statute as one that is "consistent with the historic character of the structure or of the district in which it is located."

To implement the program, and to help owners understand how to obtain certificates of rehabilitation, the Department of the Interior has promulgated regulations in 36 CFR 67. Consistent with administration policies, these regulations have recently been revised and improved. It is neither necessary nor desirable to have detailed program guidance in the Code of Federal regulations.

In order to help people understand how a rehabilitation can be "consistent with the historic character of the structure or of the district in which it

is located," the Secretary of the Interior has issued "Standards and Guidelines for Historic Rehabilitation." Only the Standards are included in CFR, but the Guidelines that interpret them are a normal part of the process of deciding whether rehabilitation projects may or may not be certified for the tax benefits.

It is useful to view the "Standards" and the "Guidelines" as separate, but closely related elements in the hierarchy. In essence, the "Standards" are a broad statement of policy at a very high level. They are general enough to cover millions of situations, and are sound enough to last many years—perhaps ten or fifteen—without revision.

The "Guidelines" explain the standards, and also begin the transition from policy into actual practice. They are set forth in parallel format, wherein practices that are *recommended* may be read in one column and compared with practices in an adjacent column that are *not recommended*. Guidelines are more specific than Standards, but, taken together, they still cover millions of situations. Also, they must be sound enough to last several years—perhaps five to ten—without revision.

With approximately this level of guidance (Statute, Regulation, Standard, and Guidelines), administration of the Tax Incentive Program began in 1977. Although some technical information was available on the subject of rehabilitation, it had not yet been related to the Standards and Guidelines, and it had not yet begun to grow as a by-product of the rehabilitation program. Two subtly different categories of technical information soon appeared: that which would be "defined" through real-life application of the Standards and Guidelines, and that which would be "discovered" through research directed at filling recognizable information needs.

As the Standards and Guidelines were applied to specific projects, and as decisions were made about which rehabilitations were certified and which were not, certain classes of

problems—and their solutions—could be recognized. When a class of problems appeared in enough certification applications to be clearly understood, and when a useful generalization could be stated about its solution, it was possible to develop technical information through the "definition" method. Now there are over sixty technical releases available under the title "Interpreting the Standards." Usually these are miniature case-studies, limited to two pages, and abundantly illustrated. They are valuable to almost anyone who carries out historic preservation projects on old buildings, but they particularly help Federal and State administrators and Tax Incentive Program applicants understand how to avoid trouble and how to reach the goal of certification.

The "discovery" approach to development of technical information is more generally understood, but is often less productive because money for research remains scarce. In this category one would place "Preservation Briefs," such as "Cleaning and Waterproof Coating of Historic Masonry Buildings," produced with NPS money and staff. Sometimes other Federal agencies have funded research of this type, with such results as Thomas Vonier Associates, Inc., *Energy Conservation and Solar Energy for Historic Buildings*, (Washington, D.C., 1981), which was financed by the Department of Energy.

Increasingly, real-life projects also are providing a source for the "discovery" approach. "Preservation Tech Notes" (see announcement elsewhere in this issue) is a new series designed to extract newly-discovered innovative technical information from projects. The net effect is to make use of projects as laboratories, and to share the results with a wide range of users. Unlike Standards and Guidelines, which are designed to remain stable over long periods, technical information must be dynamic, and able to change as needed.

This hierarchical integration of law, policy, and technical information assures faithfulness to the law and fairness and helpfulness to the user of the program. It generates and shares important new information. Perhaps best of all, it is ideally suited to a decentralized mode of administration. (What could be more decentralized than a citizen-initiated program operated with the voluntary cooperation of 57 States and Territories?)

Groundwork has been laid for extension of this system to other NPS cultural resource programs through the release in September, 1983 of the Secretary of the Interior's Standards and Guidelines for Historic Preservation Planning (including survey, evaluation, and registration, architectural and engineering documentation, and archeological data recover). As these additional Standards and Guidelines become better understood, accepted, and used, they will begin to produce technical information in the same manner as described above. Beneficiaries of the system will include not only the citizens who use the programs, local governments, and States, but also Federal agencies, including line managers within the National Park System. ©

¹Executive orders and other sources of NPS authority derive from general or specific powers of the President under the Constitution, treaties, or other law. This abstract is not intended to explain all the various sources of legal authority.

Jerry L. Rogers is Associate Director, Cultural Resources, WASO.

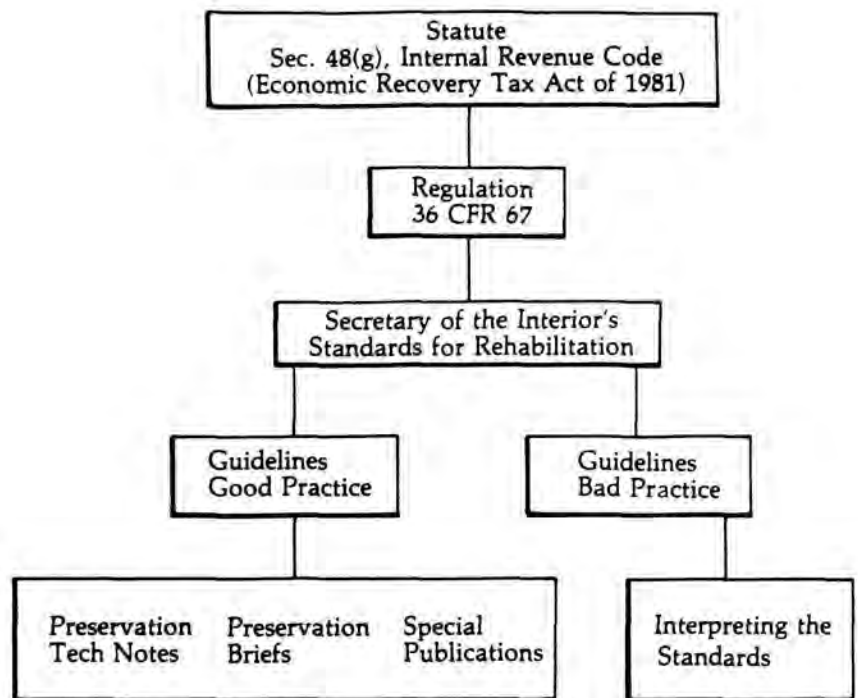

National Cemeteries . . .

continued from page 7

tionally, three sites still inter veterans' remains. The delicate and sensitive nature of this basic function creates additional management considerations.

From the transfer of the eleven War Department sites that included national cemeteries in 1933, to the inclusion of Andersonville National Historic Site in 1971, the National Park Service has endeavored to operate these areas to the highest standards. Operational requirements were first set by the War Department through the Office of the Quartermaster General and later by the Department of the Army. In 1973, however, a change in the legislative basis of the National Cemetery System presented problems for park managers.

Under the provisions of Public Law 93-43, passed in June of 1973, the administration of the National Cemetery System was transferred from the Department of the Army to the Veterans Administration. The Veterans Administration agreed to continue services formerly provided by the Army.

However, the goals and functions of cemeteries administered by the Veterans Administration differed from the primarily historic nature of National Park Service sites. Operationally, park managers were in a state of limbo.

Superintendent James V. Court of Custer Battlefield National Monument first questioned operational guidelines and uniformity among Park Service-administered cemeteries. Contact with other park managers demonstrated a need to develop policy to fill the vacuum left by the legislative changes. Through the efforts of Superintendent Court; Charles L. Vial, Superintendent of Fort Donelson National Military Park; John Tucker, Superintendent of Andersonville National Historic Site; and Edwin C. Bearss, WASO Chief Historian, the first conference on national cemeteries was held June 1984 in Washington, D.C.

The conferees agreed that specific guidelines for the operation and maintenance of cemeteries administered by the Service were necessary. In addition, CFR Title 36 needed amendment to make the provisions

concerning the cemeteries conform to the Act of 1973. To address these needs, committees were appointed, one to develop guidelines and the other to review Title 36.

The committee on guidelines met July 22-25 at the Harpers Ferry Center to discuss producing a document oriented to field needs and realities. Using the Veterans Administration regulations as a guide, the committee compiled a draft that will soon be sent to site managers for their review and comments.

The introduction states, in part, the philosophy of the National Park Service Cemetery administration:

This guideline will attempt to balance the needs of continuing use of the cemeteries and preserving them as historic entities in their own right and as integral parts of their respective parks. This guideline will also attempt to align National Park policies with those currently in use by the Veterans Administration, keeping in mind that the National Park Service-operated cemeteries are historically unique. ©

Daniel A. Brown is a Historian with Stones River National Battlefield.

C.A. THAYER in 1979 under tow to a drydock in Oakland. The key to long-term survival for these ships is good levels of daily maintenance and careful inspection of all structural elements. Areas of deterioration must be identified and replaced in a timely fashion. Not only the vessel itself must be preserved, but the traditional skills needed to keep her alive, skills which made America the leading maritime nation in the world through much of the 19th century.

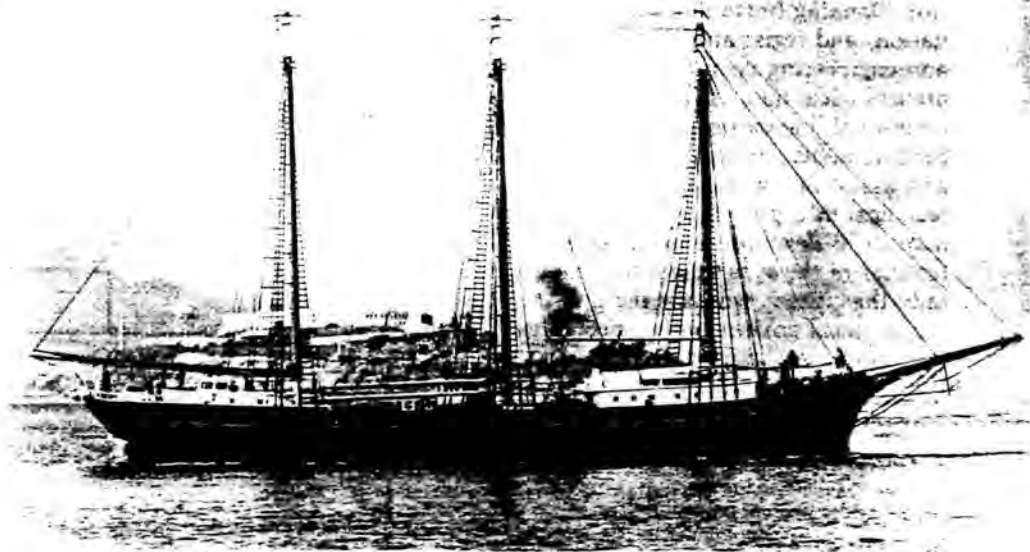

Restoration Of C. A. Thayer, 1983

Stephen Hastings

Humboldt Times, July 10, 1895: "The first vessel to be built in two years entered the waters from Bendixsen's shipyard at 2:09 o'clock yesterday afternoon. . . . Christened C. A. THAYER, the ship bore the name of the owner's secretary, Mr. Clarence A. Thayer. The citizens of Humboldt County little realized on that fine summer day that this ship was destined to live through two generations—four lifetimes as a ship's usefulness is measured.

Preservation of C. A. THAYER represents the cumulative effort of months of careful treatment as well as replacement-in-kind of rotting timbers. The maintenance of wooden sailing vessels requires a sizable investment both of Park Service money and personnel. Yet these ships are an irreplaceable cultural resource as is the craft they represent. With proper care and treatment, they do credit to the craftsman-ship and money invested in them.

C. A. THAYER, with her 219-foot overall length and her lumber capacity of 575,000 board feet, is large yet typical of the lumber schooners that sailed the West Coast. After serving seventeen years in the lumber trade, she was first sold into the salt salmon industry, and then, in 1925, to the salt cod industry, where she served until her retirement in 1950 as the last commercial sailing vessel on the West Coast. Her working days over, she re-

mained with the same owners until 1954, when she was sold for display as a "pirate ship" in the village of North Lilliwaup, Washington, then purchased by the State of California in 1956 for restoration and inclusion in its San Francisco Maritime State Historic Park. Three years later, C. A. THAYER was designated a National Historic Landmark by Secretary of the Interior, Stuart A. Udall.

A cyclic maintenance program was developed for C. A. THAYER with haul-outs in 1967, 1970, 1973, 1976, and 1979. However, maintenance could not keep pace with time, age, and continuing shortage of staff and funds. During the 1981 annual spring mast scraping, a small pocket of rot was noticed in the mizzen mast. Continued testing revealed the "small" pocket to be so severe that the welding rod probe could be pushed through one side and out the other. Further surveys showed the problem to be present in the fore and main masts as well. The search for new masts began as the mizzen was condemned and removed from the vessel.

C. A. THAYER needed a spar 107 feet long overall, with a 22½" diameter on the mizzen. The contract, let for the mizzen mast in June of 1982, was soon amended to provide for two more. However, replacement-in-kind of historic materials has its complications. The prime contractor located a man who was himself a cultural resource. At 82, Fred Lockyear took on the vast job of fulfilling the contract alone, using a magnificently complex, homemade spar lathe. Despite several unexpected problems—including shipping a 110 pound load from Oregon to California—three superior masts were delivered.

The National Park Service *Cultural Resources Management Guidelines* require the preservation of a structure's historic integrity in all maintenance activities. But as often is the case, the proper "in kind" materials necessary to preserve a structure—in this case a vessel—can be difficult to find; even with wooden sailing ships, for they were already a dying breed by the end of World War II.

In the spring of 1982, the search began for a growing list of hard-to-locate materials. The masts were in many ways the easiest; the forests of the Pacific Northwest are rich in Douglas Fir. But what of the lanyards? The ironbark for the hounds and jaws? The pine tar for the shrouds? The manila for the running rigging?

Ironbark (*Eucalyptus paniculata*) is still grown commercially in Australia, but no one in the Bay area had pieces of the size required in stock. Fortunately, Canusa Wood Products (a Canadian firm whose parent company in England produces ironbark in Australia) had a partial shipment scheduled for delivery to New York and was able to divert enough to San Francisco. Phone calls to Mystic Seaport and Galveston Historical Society (Elissa Project/White Elephant Management Company) gave us access to formulas for the pine tar coating for the shrouds. The San Francisco Giants club house manager was even consulted for sources of pine tar

closer to the West Coast. But the lanyards. . . ?

Tradition calls for the line, which is rove through the deadeyes of a ship's standing rigging, to be a true hemp (*Cannabis sativa*) fibers. The problem: with the passing of sailing ships and the advent of synthetic rope, the demand for hemp rope vanished. Calls to maritime museums and local cordage manufacturers produced some leads—Portugal, Italy, and England all might have hemp; but no, there had been no call for it in years. Companies in the United States were contacted (all 47 in the *Thomas Register, 1979*). Some said yes, but when the samples arrived they were either of manila (*Musa textilis* or Abaca plant fibers) or of unacceptably poor quality hemp. One company in Denmark, Randers Ropeworks, which maintains an office in New York, indicated they still had access to hemp fibers and agreed to do a special run.

With the materials identified and ordered, the final phase of restoration began. The tug WESTERN WARRIOR transported C. A. THAYER to Pacific Drydock Yard II in Oakland.

For the Pacific Drydock crew, it was a rare experience. One of the last yards in the Bay Area to maintain a shipwright crew and shop, they were perhaps better equipped to complete the repairs than most, yet none of the young people on the crew had regularly handled the size timbers that C. A. THAYER demands. For the yard riggers it was a learning experience none will soon forget. Peak halyards, throat seizings, shrouds, spreaders, lanyards, deadeyes—out came the nautical dictionaries as the historic ship repair began.

As the riggers researched where each piece of rigging was made fast, the shipwrights turned to tearing out the rotten and damaged wood scheduled for replacement. First came the mast partners (the blocks of wood immediately below the deck which help support the mast), then the planking. The procedure sounds simple: drill a line of holes in the block with a ship's auger, then drive home splitting wedges or a splitting bar and break out the wood. It proved to be back-breaking work, for the old growth timbers had been well-seasoned with time, and, despite the dry rot and wasted fastenings, they still came out splinter by splinter.

Pacific Drydock's rigging crew also studied the problem of removing the



The new masts in place and the hemp lanyards rove through the deadeyes, the Pacific Drydock Rigging crew begins tuning the rig.

masts. Chokers (wire rope slings) were sent aloft with a man in a personnel bucket, and carefully placed two-thirds of the way up her main mast. When all was ready and all personnel clear of the area, a strain was taken and the mast gently lifted, extending the yard's crane to its full reach. Slowly, the mast was lifted over the bulwark and laid down on the pier. Here, each of its fittings were tagged, removed, and saved. Those which were sound were re-installed on the new mast; others were used as a pattern for the fabrication of new pieces.

Later the same day, the foremast cleared the top of the deckhouse—but the extra 10 feet of lift forced the top of the mast to extend above the tip of the crane's boom. As the crane lowered away, the mast groaned in protest until the top thirty feet broke off, and landed with such force that a section of pier deck collapsed. Immediately following, a second crash was heard. The bowsprit had collapsed as well. Work began to prepare production drawings of the old bowsprit and to find a mill capable of turning it out in the shortest possible time.

With the masts free, and the senior shipwright transferring the precise

measurements from the old masts to the new, the remainder of the crew turned to her planking. An experiment on C. A. THAYER's hull began during her 1980 haul-out, when the entire underwater surface was sheathed with pressure treated plywood. To monitor the plywood's effectiveness against marine boring worms, 10 random panels (500 square feet) of this sheathing were removed, and the planks carefully inspected for signs of infestation. All indications were that the sheathing had been effective, and her pumping rate more or less constant over the past two winters, despite the severe damage she has suffered. Our inspection confirmed the success of the program—after over three years in the water no worm damage was found in the protected areas. Three years is not a thorough test for an eighty-nine year old hull; but still, this initial test gives us hope that soon we may have a better system for preserving the wooden ships in our collection.

The next two months in the yard were busy ones. The masts were stepped; a total of 600 linear feet of four-inch thick planking (ranging from four to ten inches wide) were fitted; 1.6 miles of manila rope was reaved through the freshly overhauled halyard blocks; and the new bowsprit from Neydermayer and Martin Company of Portland, Oregon was stepped and its rigging fitted. It was a critical period, for these projects would assure the long-range preservation of the ship.

Both Hull and Cargo Surveyors, and the author have spent a great deal of time studying C. A. THAYER before and during this entire period. None of the people involved in the repairs were satisfied with the limited amount of work accomplished—even though more dollars were committed to this restoration than to any work since the late 50's and early 60's. Extensive deterioration was found in her deck beams, clamps, ceilings, and ribs. Her after deckhouse was improperly caulked during an earlier restoration project, leaving signs of extensive fresh water intrusion and a major infestation of dry rot fungus. For her to be preserved ". . . for the enjoyment of future generations. . . ." as the National Park Service is mandated, a multi-year restoration program and daily preservation maintenance will be required.

continued on page 18

Conservation And Restoration To Be Performed On Rare Ordonez Cannon

Herbert D. Bump
Frank H. Gilson

Nearly 100 years after its manufacture, a rare example of an Ordonez cannon is to be preserved and restored for the National Park Service by the Research and Conservation Laboratory, Florida Department of State. Dismantled at its San Juan, Puerto Rico location, it will be shipped to Tallahassee for treatment.

Designed for coastal defense, the cannon is one of the earliest cast cannons outfitted with a steel sleeve. This practice, thought to be theoretically possible by many 19th century metallurgists, was not truly technologically successful until the 1880s. This particular example, now located at El Morro in San Juan, Puerto Rico, was designed by General Salvador

Diaz Ordonez, a trained ordnance engineer and pioneer in the development of steel sleeved cannons. The San Juan cannon represents the beginning of modern metallurgy applied to ordnance technology.

The time between the Spanish American War and World War I saw most Ordonez-type cannons melted down for scrap. Fortunately, the San Juan cannon, manufactured in the foundry at Trubia, Spain in 1891, guarded the coast of Mallorca for over sixty years. Eventually, through the generosity of the government of Spain, it was sent to El Morro as a gift to Puerto Rico and the U.S. National Park Service. Positioned in place on the lower level of the

famous Port of El Morro in 1957, it stood sentinel overlooking the Caribbean and the Channel leading into San Juan harbor. In this new environment, grave problems with corrosion became apparent. After many years of constant exposure to salt spray, this unique long-range seacoast gun began to deteriorate rapidly.

The problem of metal corrosion is common to coastal areas and a trip to any coastline will reveal many examples. The nature of the corrosion problem is chemically complex. Unprotected metal exposed to salt water in the form of sea spray becomes coated with a residue of chlorides. The chlorides, or salts, gradually penetrate beneath the surface and

Habre-De-Venture . . .

continued from page 7

Flemish bond brick. Special features include a fireplace in the breakfast room with unique tapering and an octagonal cottage in the garden patterned after the magazine building in Williamsburg, which Christopher Wren is said to have built. The home's hand-carved living room paneling is exhibited in the Baltimore Museum of Art.

The fire which went through this important landmark in 1977 not only destroyed portions of it, but also structurally weakened the walls due to badly damaged built-in continuous timber plates and nailers. Stabilization to correct this situation began in January 1981. Having surveyed damaged portions of the mansion, Magaziner suggested that park crews place a temporary covering over exposed walls to prevent water seepage. A four millimeter plastic tarpaulin, covered with 30 pounds of roofing felt, accomplished this, while the glass windows, some of which were hand-blown, were secured with boards.

In April 1983, Nicholas L. Glanopulos of Keast and Hood Co. Structural Engineers in Philadelphia, along with Mitchell Packet, Henry Magaziner, and George Church, in-

spected the site. Glanopulos proposed "internally bracing the building's walls and, at the same time, providing a temporary shed-type roof to shield the wall surfaces from runoff. The protective roof approach is . . . preferable to having the soft inner brick wall faces parged with stucco mix and the wall tops capped. Our concern is that the parged surfaces would have a tendency to internally 'dam up' absorbed water in the porous brick, thereby accelerating deterioration by insuing freeze/thaw activity."

From the beginning, Mitchell Packett had recommended protecting the home with a roof. His years of experience building local residences as well as restoring an 18th-century barn swayed the park superintendent to handle stabilization with day labor rather than outside assistance. So Mitchell took the generalized bracing diagram provided by Gianopulos and, with certain alterations approved by Henry Magaziner, completed the project in six weeks. He was assisted by park crews and two temporary maintenance workers.

Packett succeeded with: 1) boxing in chimney support bracing for strength and appearance, 2) studding upper end walls with 2 x 8's sup-

ported by ceiling plates and rafters, 3) adding additional lateral supports along the walls at the floor level for exterior support columns, 4) extending the roof eave two feet beyond recommended lengths to give further protection to exterior walls, and, most importantly, 5) extending support columns to carry all roof weight, not merely the roof weight above the damaged walls. This one change will extend the life of the walls by many years.

In the House of Representatives on July 10, 1978, Maryland Representative Robert Bauman said that the Thomas Stone National Historic Site "could easily be restored to its full beauty and operated as a working colonial residence and farm, much as is done by the National Park Service at the birthplace of George Washington, 'Wakefield,' in Westmoreland County, Virginia." This may never occur. However, thanks to critical thinking at an important time, some portion of Habre-de-Venture continues to exist as a landmark to Thomas Stone's interaction with community, state, and nation. ©

Cynthia Cosimano attends Duke University. She worked with the CRM Bulletin staff during the summer.

enter the grain boundaries of the metal. Left unchecked, this process will continue until the artifact has deteriorated into small bits of corrosion products. When the corrosion damage due to salt contamination becomes apparent, it is essential to remove the salts from the matrix of the metal before further deterioration occurs. Protective coatings applied at this point will not halt corrosion unless the salts are first removed, preferably through electrolysis.

In 1980, the Research and Conservation Laboratory used the electrolytic process to stabilize two cannons similar to the Ordonez, subjected to the same corrosive coastal environment. One important difference existed, however, a difference that soon challenged the ingenuity of both our laboratory and the El Morro staff.

Our laboratory had conserved the Fort DeSoto cannons almost in place, but certain unique conditions at El Morro made *in situ* treatment impossible. Shipping the cannon to our Tallahassee laboratory also presented problems due to the size and location of the seacoast gun.

Getting heavy lifting equipment through the narrow sally port and down the long steep ramp to the cannon did not appear to be a workable solution. Dismantling cannon and carriage and moving them piecemeal seemed easier, but posed difficult problems of their own. For one thing, the enormous size of both cannon and carriage made even piecemeal removal difficult. In addition, every minor component was so solidly welded with corrosion that it initially seemed impossible to disassemble the cannon without incurring major damage.

To allow removal of the cannon and its accessories, the front-pintle arm connecting the unit to the emplacement had to be severed with a cutting torch. Cutting the pintle arm freed the cannon from its base pintle mechanism. The trunion caps securing the cannon to its carriage were the next major concern. Welded tightly in place by corrosion, they could not be swung open to free the cannon from its carriage. Again, to minimize damage, a cutting torch was used. Thanks to the excellent cutting skills of an El Morro staff member, the attempt was successful and there was no damage to cannon, carriage, or trunion caps. Separated into cannon, carriage, and base, the units appeared ready for removal.

Only one major obstacle still remained. Helicopter removal of the base and carriage posed no problem. The carriage weighed only about 3,000 pounds, a relatively light load for a helicopter, and the base was even lighter. But locating a helicopter to lift the 16-foot, 10,000 pound cannon became the challenge. Finally one became available in March 1984. With no difficulty the base, carriage, and cannon were lifted from the fort's lower level and placed outside the fort at a location convenient for later pickup and loading onto a ship.

The Research and Conservation Laboratory will eventually receive the cannon in New Orleans and bring it

to Tallahassee where the major task of conservation and restoration will begin. As the Ordonez cannon project progresses, this laboratory will make room in its forty-foot long electrolysis tanks for the cannon's arrival. The smaller 17th- and 18th-century naval cannons will have completed their treatment by the time the cannon arrives, and all will be in readiness for the second phase of the Ordonez cannon conservation project. ©

Herbert D. Bump is a Historic Conservator, and Frank H. Gilson is an Archeological Illustrator working as a Laboratory Technician. Both authors are with the Florida Department of State, Research and Conservation Laboratory.

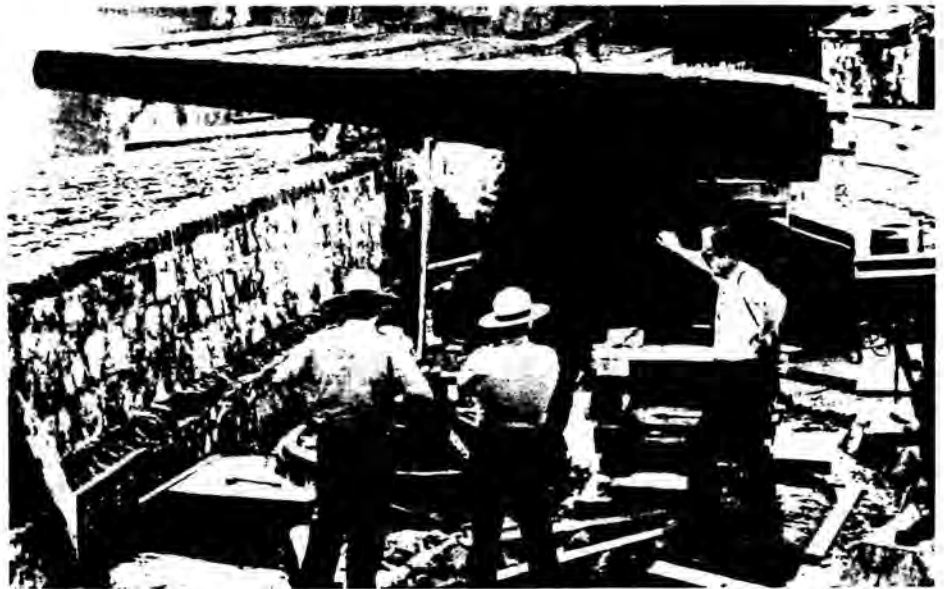

Ordonez cannon being disassembled prior to being airlifted.



Base pivot mechanism being airlifted from the lower deck of El Morro.

FEEDBACK

Hugh C. Miller

The idea is not new! The CRM BULLETIN was started to exchange technical information, but the very people who should be exchanging say they are too busy to write an article. We don't need articles. We need ideas, reminders, lessons learned, and cautions. It is clear to me that most structural failures, including failure of repairs or maintenance efforts, do not result from lack of information but from the non-application or mis-application of available information.

What kind of information should be in FEEDBACK? I see anything related to the treatment—preservation, stabilization or restoration—of prehistoric or historic sites, structures, or objects as useful. The information does not have to be definitive, but it should be thought-provoking. We have all done, seen, or heard about "something that worked," "looked like it worked," or "didn't work." For example, feedback I've heard or received looks like this...

The publication, *Accommodation of Disabled Visitors at Historic Sites in the National Park System*, contains a variety of retrofit techniques which will facilitate physical access while maintaining historic integrity and sensitivity. Also valuable is Appendix I, "Selected Devices to Assist Disabled Persons," which lists specific aids, uses, and manufacturers. However, on page 68 of Appendix I in the section Toilet Fixtures, a "Handi John" manufactured by Braun Fiberglass Products is listed as an "accessible portable restroom." Steve Stone, Outdoor Recreation Planner/Senior Access Consultant, Denver

Service Center, recently had the opportunity to personally inspect the Braun "Handi John."

In his opinion, another prefabricated unit demonstrates conspicuously higher ease of accessibility and usability. Monogram Industries, Inc., 1945 East 223rd Street, Long Beach, California 90810, (213) 830-0188 manufactures the Model 700 portable accessible unit. The Model 700 unit provides opportunities to accommodate the wheelchair-user and an assistant (if necessary) inside the unit with the door closed, thus ensuring needed privacy. These are vital requirements not currently reflected by the Braun "Handi John."

Denis Galvin
Denver Service Center

The maintenance division of Independence National Historical Park has been using the water repellent formula suggested by Chief Historical Architect Hugh C. Miller and developed by the Forest Service, U.S. Department of Agriculture ("*Wood Preservation: Poison Free*" by Hugh C. Miller, AIA, CRM Bulletin, Vol. 2, no. 1, March 1979). Independence National Historical Park general foreman, Ross Flanagan, has the following observations and suggestions to pass on.

Using the Forest Service proportions (3 cups exterior varnish, 1 oz. paraffin wax, and enough solvent such as mineral spirits, paint thinner or turpentine to make 1 gallon), we have been mixing fifty-five gallon batches for dipping newly fabricated wood paneled shutters. The dipping is done in twelve-inch deep pans made of galvanized sheet metal soldered at the folded corners. Hose bibs were attached to bottom drains in the pans, and non-explosive pumps transferred the liquid to and from the pans through the hose bibs.

When dipping assembled millwork, wait until no more air bubbles rise to the surface before "counting" the dipping time which must last a minimum of three (3) minutes. Often, it is more practical to dip for about 30 minutes so that other tasks can be done in the meantime. Once dipped, the millwork is lifted out of the pan, stood to dry on stick spacers, and allowed to drip onto newspapers.

If the millwork is too large to dip, then the repellent can be brushed on. Keep applying coats while wet until the surface looks like it is varnished and feels like it has been hand rubbed with wax. If cuts are to be made during installation, all cut edges should also be brushed with the repellent.

Handling the treated millwork is no problem, and the treated surfaces, after about three days drying time, take oil or shellac-based paint very well.

It is the mixing process which is somewhat tricky. When preparing a large quantity it is best to melt the full amount of paraffin needed and then mix it all into a gallon of the solvent. They will readily mix if the solvent is warm, i.e., has been standing near a warm radiator for some time. This mix can then be added to the large quantity of the varnish and solvent mix. Never apply direct heat to the solvent or to the final mix as the liquid is extremely volatile. Heat lamps can be directed to the underside of the pans to keep the mix warm.

Storage of the mix is possible and recommended at the end of each day as long as the liquid is pumped from the pan back into cans which are totally filled and sealed tight. Air must be kept out of cans as it causes the paraffin to congeal.

Penelope H. Batcheler
Independence NHP

continued on page 17

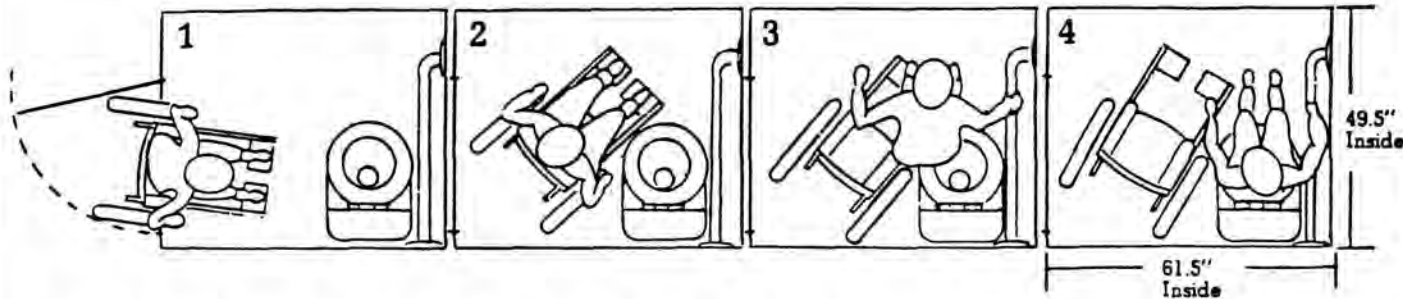

Technique For Transfer From Wheelchair To Toiletstool In Jet-O-Matic® Model 700 Cabana

National Park Service Assists U.S. Participation In World Heritage Convention

James H. Charleton

The World Heritage Convention, an international agreement to which the United States is a party, seeks to protect properties around the world that are of exceptional natural and cultural importance. Listed properties may benefit from certain international financial and technical assistance programs. They also receive a World Heritage plaque. The World Heritage program is the international equivalent of the National Historic Landmarks Program.

In the United States, the State Department and the Department of the Interior share responsibility for coordinating participation in the World Heritage Convention, including the selection and preparation of nominations to the List. The National Park Service is the lead agency within the Department.

To date, the following cultural properties in the United States have been inscribed on the World Heritage List: Mesa Verde National Park, Colorado; Independence Hall, within Independence National Historical Park, Philadelphia, Pennsylvania; Cahokia Mounds State Historic Site, Illinois; and La Fortaleza — San Juan National Historic Site, Puerto Rico.

Yellowstone National Park has been recognized for both its natural and cultural merits. The World Heritage Committee, an international committee of nations that have agreed to the Convention, will vote this fall on whether to accept the most recent World Heritage cultural nomination by the United States, the Statue of Liberty National Monument, New York-New Jersey.

Within the Service, the International Affairs Branch and the History Division cooperate to prepare and review World Heritage cultural nominations. Nominations are scrutinized by the Interagency Panel on World Heritage, which is chaired by the Assistant Secretary for Fish and Wildlife and Parks, before they are submitted to the World Heritage Committee. Cultural nominations are selected from units of the National Park System, other federally-owned areas of great importance, and the list of National Historic Landmarks. In the past, the parks that have been nominated have assisted the Washington Office in complying with the exacting formalities of nomination and have held impressive dedication ceremonies.

In 1984, the Service is preparing nominations of Chaco Culture National Historical Park, New Mexico, and Pu'uhonua o Honaunau (formerly City of Refuge) National Historical Park, Hawaii. Mr. James Judge, Chief, Cultural Research Division, Southwest Cultural Resources Center, and his staff will draft the nomination of Chaco Culture National Historical Park. Superintendent Jerry Shimoda and the staff of Pu'uhonua o Honaunau National Historical Park will prepare that nomination. If the Interagency panel on World Heritage accepts the completed nominations, they will be forwarded to the World Heritage Committee by January 1, 1985, and will be considered for listing in the fall of that year.

Suggestions for future U.S. nominations are solicited on an annual basis, in the spring of each year, but may be directed at any time to the International Affairs Branch of the Washington Office. ©

James H. Charleton is a Historian in the Washington Office.

Update on the National Catalog

Cara Sutherland

Revised and streamlined accessioning, cataloging, and other museum record keeping procedures will be available to parks in Fall 1984 when the *Museum Handbook, Part II: Museum Records* is distributed. The accessioning and cataloging procedures outlined in the *Handbook* have been improved in order to facilitate museum record-keeping in parks. Important changes include the following:

1. The application of lot cataloging to all areas of collections.
2. Revised registration forms, including new museum catalog records—one for Cultural objects, another for Natural History objects.
3. A three-step registration process. Step 1 covers accessioning and is completed upon receipt of the

objects. Step 2 records basic "registration data" on the museum catalog record and is completed soon after receipt of the objects. Step 3 provides more detailed "catalog data" on the museum catalog record and completes the cataloging process. Steps 1 and 2 are quick and allow parks to establish basic accountability soon after receipt of the objects. Step 3 can be completed at a later date. This should aid parks in reaching full accountability for their collections in a phased process.

4. Revised classification systems for some disciplines and specific instructions for cataloging col-

lections by discipline (e.g. History, Geology, etc.)

This revised cataloging system is the work of the National Catalog Steering Committee, a group of curators and field specialists from throughout the National Park Service, and the Curatorial Services Branch, WASO. For the past two years, the Committee and the Branch worked on developing policy and procedures leading to full accountability of NPS collections. Subcommittees were established by discipline (History, Archeology, Ethnology, and Natural History) and given the responsibility of making recommendations for discipline-specific changes to the system. Testing of the new system was carried out in selected parks in the Fall of 1983 and the *Museum Handbook, Part II: Museum Records* was sent out for field review in the Spring of 1984. Changes were made

continued on page 17

CAMPBELL CENTER 1984 WORKSHOP SERIES

The Campbell Center for Historic Preservation Studies is conducting fall workshops in program areas which include Conservation of Wooden Buildings, Architectural Preservation, Care of Museum Objects, and Furniture Conservation. A "hands-on," practical, in-depth approach is featured at each workshop, taught by faculty members from such institutions as Parks Canada, Colonial Williamsburg, and the Winterthur Museum. The Computerization of Collections Workshop sponsored jointly with the Smithsonian Institution, will be taught by the Smithsonian Registrar.

Workshops are scheduled from September 10 to November 14, with many to be repeated in the Spring 1985 series. Brochures on major program areas and individual workshops are available from: Margery Douglass, Registrar, Campbell Center, P.O. Box 66, Mt. Carroll, IL 61053, (815) 244-1173.

NEW PUBLICATION AVAILABLE

The Foundation for Preservation Technology (FPT) announces the publication of *The Technology Of Historic American Buildings*, H. Ward Jandl, Editor. Illustrated with over 200 photographs and drawings, the 225-page softcover volume is the result of a 5-year research program funded by the National Endowment for the Humanities. Topics range from the development of hand-forged iron builders' hardware to decorative metal roofing and terra cotta. A useful reference, the publication contributes to our understanding of a building's original fabric, materials, structural systems, and other aspects associated with its construction.

Send check or money order for \$19.95 (plus \$2.00 postage and handling) for each book to FPT, GBR Publications Department, 1200 15th Street, NW, Suite 103, Washington, DC 20005. For orders shipped outside of the U.S., add 15% of the total order (\$15 minimum).

CLARIFICATION

The July, 1984 issue of the CRM BULLETIN included a short article on tax incentives for rehabilitating historic buildings. Focusing on the role of the NPS in administering the program, the article neglected to detail the very real role of the State Historic Preservation Offices in screening initial applications, meeting with owners and architects on site to work out details of projects in accordance with the Secretary's Standards, performing substantive review and transmitting recommendations to the NPS, and assisting owners with the preparation of historic preservation certification applications. The author and NPS regret this important omission.

NATIONAL COMPUTERIZED ARCHEOLOGICAL DATA BASE

The Archeological Assistance Division in the Washington Office is developing a comprehensive archeological and cultural resource data base intended to serve as a management tool for Federal agencies, the private sector, and the States. The data base should be useful in reducing redundancy in archeological and other cultural resources and will form the backbone of an effective planning process as envisioned in the Resource Protection Planning Process (RP3). In addition, the data is expected to provide for more efficient oversight and coordination of the overall national archeological and historic preservation program.

The proposed data base design will provide high level information by focusing on two primary areas: (1) work which has been done and work currently being done, where it is, what reports are available, and where more information can be obtained; and (2) what data bases are available and how to access them.

A pilot project, using the Southeast Region's (SERO) data base, will look at problems of data collection, information exchange between the States, Regions and the Washington Office, levels of effort required, problems of

standardization, data entry, implementation on a larger scale, hardware and software needs, and level of technical expertise required for developing and maintaining a system. For the pilot, the Washington Office will coordinate the overall project. It will design the data base system using the ORACLE data base management system on the IBM PC; it will compile a nationwide catalog of existing data bases which will form a major component of the data base effort; it will construct the data base for the bibliographic project and data base relations and will design applications programs to capture and edit data which presently exists in the SERO and Georgia data bases. The Southeast Region will edit and enter the revisions to the data base which will be required as part of the conversion from their existing TAXIR system to the new program. The Region already has a bibliographic data base consisting of several thousand entries for projects throughout the southeast. Arkansas will design, develop, and implement a prototype system for computerized citation and project data using the INFORMIX data base management system, which is currently available on a wide range of PCs and can serve as a fallback system should there be some problems with the availability of ORACLE on micro systems. It will also provide a good test of the portability of the design. Arkansas will also be responsible for preparing the necessary documentation to go with the system and the guidelines for its use and operation; and will input its data into the SERO data base. Georgia will represent the interests of the "have nots." Since part of the Georgia data base already resides in the SERO data base, they will be responsible for updating and editing. They will also serve as a laboratory test case for studying the problems of implementation at the State level and the application of the system to other categories of historic preservation data.

The CRM BULLETIN will run updates on this project in future issues. For further information contact the Chief, Archeological Assistance Division, WASO.

THE GEORGE WRIGHT SOCIETY

The George Wright Society will hold its second Triennial Resources Management Conference in November, 1985 in New Orleans and will begin conference planning early this fall. The conference theme will be "Cooperation and Communication Among the Natural and the Cultural Resources and the Planning and the Management Disciplines." A call for papers, including organized symposia, will be made this fall. Emphasis will be placed on the applications of research to natural and cultural resources planning and management decisions; and on the interrelationships of the natural and social sciences, the humanities, and the arts to management, conservation, interpretation and protection of natural and cultural resources set aside in parks or equivalent reserves.

Write Mr. Douglas H. Scovill, President, The George Wright Society, 7726 Brandeis Way, Springfield, VA 22153, to be placed on the mailing list for the Call for Papers this Fall.

CRM Bulletin Deadlines

Please submit articles to the editor by the following dates:

- November 1—deadline for the January issue
- February 1—deadline for the April issue
- May 1—deadline for the July issue
- August 1—deadline for the October issue

Correspondance regarding guidelines for manuscripts, as well as information on receiving the BULLETIN, should be addressed to:

Editor
CRM BULLETIN
National Park Service
18th & C Sts., NW
Washington, DC 20240

I wish we had thought it out!

About five years ago, following the suggestion of a maintenance worker, we spread rock salt around the base of stone monuments to keep the weeds down and make edge trimming unnecessary. It worked.

There was a bit of dead grass around the monuments but we thought it was "O.K." After a few years, we noticed moisture staining and salt crystals on the stone, but thought little about it. Now some of the surface is deteriorating and breaking off, with soft stone material.

We talked to a professor of chemistry at a nearby college who explained that the salt worked into the stone, then attracted water on the surface. When the stone got hot from the sun, salt crystals formed (efflorescence), then at night the salt in the stone attracted more water from the air.

This continuing cycle has caused the stone to decay. He said there was nothing we could do to stop the decay process as long as salts are in the stone. We have stopped using salt as a grass control and are now working with the regional office to develop a way to soak the salts out with a poultice.

*Anonymous Chief of Maintenance
Battlefield Park*

Food for Thought

During a recent visit with John Larson, Chief Conservator of the Victoria Albert Museum in London, he showed me damage to the bottoms of the museum's stone statuary that are setting on concrete bases. He attributes this to the migration of salts and sulfates into the concrete from the moisture absorbed from the air.

If this happens inside, it certainly can happen in a building when concrete is in contact with stone, terra cotta, etc. Most construction or repair work does not consider these chemical factors. However, the Lead Institute cites the use of lead to separate the new concrete foundation from the historic stone work at the Gracey Mansion in New York City. Is this a detail we should consider?

*Hugh C. Miller, AIA
WASO*

as a result of the testing and field comments, and the final draft was approved by the Committee in May 1984.

The "Instructor's Workshop in NPS Cataloging," held at Mather Training Center in June 1984, was the first step in implementing the revisions to the *Handbook, Part II: Museum Records*. This workshop trained regional curators and other field curators to serve as trainers in the new system. Regional workshops will be conducted for other field personnel through FY 85. The task of these workshops is to ensure that participants know the basic procedures that are currently prescribed and that they know how to use the *Museum Handbook, Part II: Museum Records* to solve problems that may arise in the course of accessioning and cataloging in the field. The Servicewide goal is to gain accountability of museum collections in a timely manner. Presently, an estimated 90% of NPS collections are uncataloged.

The *Museum Handbook, Part II: Museum Records* is now being printed and will be available to the parks in the Fall of 1984. With the exception of the Natural History classification schemes, it is in final form. The Natural History sections are being issued in draft pending critical peer review outside the National Park Service. Following regional review of these classification schemes, they will be finalized in mid-1985.

The National Catalog Steering Committee is now focusing its attention on making servicewide recommendations for computerization of the system at the park level. Pilot computer programs have already been developed at several parks. A feasibility study on computerization is expected to be completed by the end of 1984. The Committee has done its work in providing a system which should help parks improve accountability. It is up to the parks to use the revised system to its best advantage in gaining accountability for their collections. ©

Cara Sutherland is a Museum Technician, Branch of Curatorial Services, WASO.

continued on page 18

C.A. Thayer . . .

continued from page 11

We are now gathering information and programming for future preservation as we study the magnitude of the challenge offered by the ships. Much data was gathered during C. A. THAYER's drydocking this year and steps were taken to protect the money invested in the work: the timbers used in the repairs were ordered months in advance and pressure treated with wood preservative to help control dry rot fungus; all frame areas were liberally sprayed with a wood preservative; over 600 pound of salt blocks were placed on the salt shelves between her frames; and an active volunteer program was initiated to provide the level of regular care impossible with the park's limited crew. Research is also being conducted on the feasibility of injecting the masts and bowsprit with a fungicidal fumigant, proven effective for up to 20 years by Oregon State University where it was developed and is being tested.

Many a decade has passed since that fine summer day in 1895 when she first took the water, but C. A. THAYER still provides a very tangible link to the past; and with proper

Feedback . . .

continued from page 17

Send or phone your FEEDBACK to me:

Hugh C. Miller, Chief Historical Architect
Cultural Resources, National Park Service
18th & C Sts., NW
Washington, D.C. 20240
(202) 343-8146.

It should be short and simple, but we need to know what you know about your particular subject area. (We'll need your address and phone number also.) If you want to remain anonymous, let us know that too.

We will treat all ideas as "best-available" information. Subject specialists will be asked for their views on the general application of the information, and we will include comments and cautions if necessary. ©

care, this ship, destined to live through two generations, may now live through several more. ©

Stephen Hastings is Marine Maintenance Foreman, Cultural Resources (Maritime) Unit, Golden Gate National Recreation Area.

October 22-30
National Trust for Historic Preservation, Baltimore, MD.
Restoration of Vintage Houses by Reg. E. Graham, AIA, and James C. Massey. Contact: National Building Museum, 440 G St., NW, Washington, D.C. 20001.

October 31-November 2
Financial and Tax opportunities for Old Buildings by Edwin Finder, Thomas Coughlin, James Massey, and Margaret Drury. Contact: National Building Museum, 440 G St., NW, Washington, D.C. 20001.

November 15-18
Successful Rehabilitation. Sponsored by the National Park Service, the National Trust for Historic Preservation, and the Association for Preservation Technology. Contact: Holly Riser, NTHP, 1785 Massachusetts Ave., Washington, D.C. 20036. Phone: (202) 673-4100.

December 27-30
American Historical Association, Chicago, Ill.



October 1984

Published quarterly by the Associate Director, Cultural Resources, in the interest of promoting and maintaining high standards in the management of those cultural resources entrusted to the National Park Service's care by the American people.

Director: Russell E. Dickenson
Editor: Mary V. Maruca
Assistant Editor: Karlota M. Koester
Graphic Design: Northlight Graphics

Cultural Resources, Washington, D.C.

IN THIS ISSUE . . .

Strategic Goals . . .	1
Keane Wonder . . .	1
. . . Geohm 3	3
Guns Over Potomac . . .	4
National Cemeteries . . .	7
Stabilization Process on Habre-De-Venture . . .	7

The Integration of Law . . .	8
Restoration of C.A. Thayer . . .	10
. . . Ordonez Cannon	12
Feedback . . .	14
World Heritage Convention	15
. . . National Catalog	15
Announcements . . .	16
Calendar of Events . . .	18

Cultural Resources
National Park Service
U.S. Department of Interior
Washington, D.C. 20240

Postage and Fees Paid
U.S. Department of the Interior
INT 417

