

Re_ OPO_ PA draft #3 REMINDER for Signatory Rev....pdf

From: [Woodbury, Brian](mailto:Woodbury.Brian)
To: daniellebreaux@turkadvisory.com
Cc: [Carolyn Richard@nps.gov](mailto:Carolyn_Richard@nps.gov); [James Perry@nps.gov](mailto:James_Perry@nps.gov); [Henson, Jamie \(DDOT\)](mailto:Henson_Jamie@ddot.gov); murat.oday@dc.gov; [David Orowitz](mailto:David_Orowitz@dc.gov); [Faisal Hameed \(faisal.hameed@dc.gov\)](mailto:Faisal_Hameed@dc.gov); [Jamie Keller@nps.gov](mailto:Jamie_Keller@nps.gov); [Saadat Khan \(saadat.khan@dc.gov\)](mailto:Saadat_Khan@dc.gov); robin_nixon@nps.gov; william_cheek@nps.gov; [Andrew Weiss](mailto:Andrew_Weiss@gsa.gov); [Brett Banks \(brett.banks@gsa.gov\)](mailto:Brett_Banks@gsa.gov); nancy.witherell@gsa.gov
Subject: Re: OPO: PA draft #3 REMINDER for Signatory Review/Comment
Date: Thursday, January 31, 2013 6:06:12 AM

Hi Danielle,

Our apologies for NPS not being able to respond yet. We intend to comment however we will need another week to do so. On Monday, we are having an internal meeting on this subject and the property to be transferred - the topic of the meeting will also help us address the questions for the EA.

Kind Regards,

Brian

On Wed, Jan 30, 2013 at 9:48 AM, daniellebreaux@turkadvisory.com <daniellebreaux@turkadvisory.com> wrote:

Dear DDOT, NPS and Trump,

Comments to the OPO PA Draft #3 were due yesterday. If you are receiving this message it is because we have not received any comments from your agency/organization. **Please let me know if you intend on sending comments and if so, please let me know when you will be able to submit comments so we can plan accordingly.**

Thank you,

Danielle

Danielle Breaux

Office of Campus Development

Tel 202.288.1298

Em daniellebreaux@turkadvisory.com

From: daniellebreaux@turkadvisory.com
Sent: Tuesday, January 22, 2013 4:52 PM

To: Andrew Lewis (andrew.lewis@dc.gov); David Maloney (david.maloney@dc.gov); 'Carolyn_Richard@nps.gov'; 'James_Perry@nps.gov'; 'Henson, Jamie (DDOT)'; 'murat.omay@dc.gov'; 'Kirsten B. Kulis'; Louise Brodnitz; 'David Orowitz'; 'Dettman, Shane'; Faisal Hameed (faisal.hameed@dc.gov); 'Jamie_Keller@nps.gov'; Saadat Khan (saadat.khan@dc.gov); 'Brian_Woodbury@nps.gov'; 'Hirsch, Jennifer'; 'nancy.witherell@gsa.gov'; 'Brett Banks (brett.banks@gsa.gov)'; 'Tom McDowell - WPDA'; 'kevin.terry@gsa.gov'; 'beth.savage@gsa.gov'; George Siekkinen (george.siekkinen@gsa.gov); 'robin.nixon@nps.gov'; 'william_cheek@nps.gov'; 'Andrew Weiss'; 'Nancy Witherell'; 'Perry, James'; 'Carolyn_Richard@nps.gov'
Subject: OPO: PA draft #3 for Signatory Review/Comment
Importance: High

Dear OPO PA Signatories and NPS,

Attached is the **OPO PA Draft #3 for your review and comment** (please note the pdf and word version attached are the *SAME*).

This draft captures comments/edits made on the PA draft #2 during our January 16th PA meeting as well as some language edits provided by DCSHPO following the meeting. We have used comment boxes to note items DDOT and NCPC wanted to review and may provide language edits. We have also provided potential future language edits in the comment boxes related to the NPS Penn Ave jurisdiction – GSA and NPS continue to work out this issue but wanted to denote potential language edits and notes as we move forward in the event these elements advance.

Review/Comments:

Please send me your track changes version of the PA Draft #3 by January 29th (include any non-edit notes/comments you have using comment boxes within the document or via email). *Please do not send your comments to all parties on this email to aid in minimizing email traffic and avoid any confusion with revisions as we move forward.*

Schedule:

GSA is planning to issue the HSR Chapter 9 – Treatment Chapter to the Signatories tomorrow for your review and comment. We are also hoping to issue a draft of the Work Exempt from Review list by the end of this week. **Our goal is to meet with the Signatories on February 7th to discuss comments to the PA Draft #3, HSR Chapter 9 as well as the Work Exempt from Review list.** As before, GSA will prepare a consolidated comment draft of the PA and will send pdf's of all agency/organization comments received prior to the meeting.

NOTE: If your agency/organization is unable to provide comments to the PA Draft #3 by

January 29 or has a conflict with the February 7 meeting date, please contact me directly and we can look to identify alternative times to meet with your agency to discuss your comments. We will send out meeting invites for the February 7th meeting by the end of the week.

Please do not hesitate to contact me with any questions. Thank you in advance for your participation in this important process and we look forward to meeting with you on February 7th.

Danielle

Danielle Breaux

Office of Campus Development

Tel 202.288.1298

Em daniellebreaux@turkadvisory.com

--

Brian M. Woodbury
Chief of Lands
National Park Service - National Capital Region
1100 Ohio Drive, SW
Washington, DC 20242
(202) 619.7034
brian_woodbury@nps.gov

Re_ FINAL PA - Ready for Signature.pdf

From: [Hamilton, Kristen](#)
To: daniellebreaux@turkadvisory.com
Cc: [Lewis, Andrew](#); [Maloney, David \(OP\)](#); [Kirsten B. Kulis](#); [Louise Brodnitz](#); [David Orowitz](#); [Dettman, Shane](#); [Andrew Weiss](#); [Hirsch, Jennifer](#); [James Perry@nps.gov](mailto:James_Perry@nps.gov); [joel gorder@nps.gov](mailto:joel_gorder@nps.gov); [carolyn richard@nps.gov](mailto:carolyn_richard@nps.gov); [Nixon, Robin](#); [Jamie Keller](mailto:Jamie_Keller@nps.gov); [Brian Woodbury@nps.gov](mailto:Brian_Woodbury@nps.gov); [Steve Lorenzetti@nps.gov](mailto:Steve_Lorenzetti@nps.gov); danielle.breaux@gsa.gov; [Antonio Alonso - WPDA](#); [Frank Palermo](mailto:Frank_Palermo@gsa.gov); [Brett Banks \(brett.banks@gsa.gov\)](mailto:Brett_Banks@gsa.gov); kevin.terry@gsa.gov; [Edmund Newman - WPS](#); nancy.witherell@gsa.gov; [George Siekkinen \(george.siekkinen@gsa.gov\)](mailto:George_Siekkinen@gsa.gov); beth.savage@gsa.gov; [Henson, Jamie \(DDOT\)](#); [Omay, Murat F. \(DDOT\)](#); [Khan, Saadat \(DDOT\)](#)
Subject: Re: FINAL PA - Ready for Signature
Date: Tuesday, May 21, 2013 1:51:48 PM
Attachments: [NPS signature page.OPO PA.5.21.13.pdf](#)

Danielle,

Attached is the signature page from the National Park Service. Thank you for all the work and coordination to finalize this agreement.

-Kristen

Kristen Hamilton
Environmental Protection Specialist
Division of Resource Management
National Mall and Memorial Parks
900 Ohio Drive SW
Washington, DC 20024
(202) 245-4674 office
(202) 360-1476 cell

On Thu, May 16, 2013 at 3:43 PM, Hirsch, Jennifer <jennifer.hirsch@ncpc.gov> wrote:

Danielle,

Please see attached for NCPC's signature page. Thanks to everyone for their efforts on this project.

Jennifer

Jennifer Hirsch | AICP

Federal Preservation Officer | Urban Design and Plan Review

National Capital Planning Commission

401 9th Street, N.W. | Suite 500

Washington, D.C., 20004 | 202-482-7239

jennifer.hirsch@ncpc.gov

Please consider the environment before printing this e-mail

From: Lewis, Andrew (OP) [mailto:andrew.lewis@dc.gov]

Sent: Thursday, May 16, 2013 3:20 PM

To: daniellebreaux@turkadvisor.com; Maloney, David (OP); 'Kirsten B. Kulis'; 'Louise Brodnitz'; 'David Orowitz'; Dettman, Shane; Hirsch, Jennifer; 'Andrew Weiss'; James.Perry@nps.gov; joel.gorder@nps.gov; (carolyn_richard@nps.gov); 'Nixon, Robin'; Jamie Keller; Brian.Woodbury@nps.gov; Kristen Hamilton; Steve.Lorenzetti@nps.gov

Cc: danielle.breaux@gsa.gov; Antonio Alonso - WPDA; Frank Palermo; 'Brett Banks (brett.banks@gsa.gov)'; 'Kevin.Terry@gsa.gov'; Edmund Newman - WPS; nancy.witherell@gsa.gov; 'George Siekkinen (george.siekkinen@gsa.gov)'; beth.savage@gsa.gov; Henson, Jamie (DDOT); Omay, Murat F. (DDOT); Khan, Saadat (DDOT)

Subject: RE: FINAL PA - Ready for Signature

Hello Danielle:

The SHPO signature page is attached. Thanks to you and all other parties for your efforts in completing this PA. We look forward to receiving an electronic copy of the fully executed agreement as soon as possible.

Best,

C. Andrew Lewis
Senior Historic Preservation Specialist
DC State Historic Preservation Office
Office of Planning
1100 4th Street, SW
Suite E650
Washington, DC 20024
Phone: 202-442-8841
Fax: 202-442-7638
andrew.lewis@dc.gov
www.planning.dc.gov/hpo

Play DC is an ambitious program to renovate 32 District play spaces across the city and improve your quality of life.

Click [here](#) for more information on this [DPR](#) and [DGS](#)-driven initiative.

From: daniellebreaux@turkadvisory.com [<mailto:daniellebreaux@turkadvisory.com>]

Sent: Thursday, May 16, 2013 2:59 PM

To: Lewis, Andrew (OP); Maloney, David (OP); 'Kirsten B. Kulis'; 'Louise Brodnitz'; 'David Orowitz'; 'Dettman, Shane'; 'Hirsch, Jennifer'; 'Andrew Weiss'; James.Perry@nps.gov; joel.gorder@nps.gov; (carolyn_richard@nps.gov); 'Nixon, Robin'; Jamie Keller; Brian.Woodbury@nps.gov; Kristen Hamilton; Steve.Lorenzetti@nps.gov

Cc: danielle.breaux@gsa.gov; Antonio Alonso - WPDA; Frank Palermo; Brett Banks (brett.banks@gsa.gov); kevin.terry@gsa.gov; Edmund Newman - WPS; nancy.witherell@gsa.gov; 'George Siekkinen (george.siekkinen@gsa.gov)'; beth.savage@gsa.gov; Henson, Jamie (DDOT); Omay, Murat F. (DDOT); Khan, Saadat (DDOT)

Subject: OPO: FINAL PA - Ready for Signature

Importance: High

All –

GSA has signed the **FINAL OPO PA** and attached is the clean copy (*it is the same one that I sent out this morning*) for your agency/organization signature.

We are requesting signature by your agency/organization by **COB Wednesday May 22nd.** If your agency/organization is unable to meet this deadline contact me or Nancy.

Once your agency/organization signs – please send me the electronic copy of your signature page (we do not need the entire document) and hold on to your original copy. I will coordinate with you for a GSA representative will collect the original signature pages from you the week of May 27th.

Please do not hesitate to contact Nancy or me with any questions.

Thank you for your time and efforts associated with this project.

Danielle

Danielle Breaux

Office of Planning & Design Quality

Tel 202.288.1298

Em daniellebreaux@turkadvisory.com

NPS signature page.OPO PA.5.21.13.pdf

SIGNATURE PAGE
PROGRAMMATIC AGREEMENT
REGARDING
THE GROUND LEASING, REHABILITATION AND ONGOING MAINTENANCE
AND STEWARDSHIP OF THE
OLD POST OFFICE BUILDING AND ANNEX,
AND
ASSOCIATED TRANSPORTATION IMPROVEMENTS
WASHINGTON, D.C.

NATIONAL PARK SERVICE



5/21/13

By:

Robert A. Vogel
Superintendent

Date:

Trump Event- August 8th.pdf

From: [Amanda Miller](#)
To: Robin_Owen@NPS.GOV
Cc: [Lisa Tully\(Google App\)](#)
Subject: Trump Event- August 8th
Date: Sunday, July 21, 2013 1:14:26 PM
Attachments: [image001.png](#)

Hi Robin-

I hope you are well! I left you a voicemail on Friday with my colleague Lisa Tully. We were hoping to talk with you for a few minutes to discuss protocol for an event we would like to host at The Old Post Office Building on August 8th.

If convenient for you, we would love to jump on a quick call tomorrow.

Let us know. We appreciate your assistance in advance.

All the best,
Amanda

T R U M P

THE TRUMP ORGANIZATION

Amanda Miller

Vice President, Marketing

725 Fifth Avenue | New York, NY | 10022

p. 212.836.3218 | f. 212.688.8135

amiller@trumporg.com | trump.com

This e-mail message, and any attachments to it, are for the sole use of the intended recipients, and may contain confidential and privileged information. Any unauthorized review, use, disclosure or distribution of this email message or its attachments is prohibited. If you are not the intended recipient, please contact the sender by reply email and destroy all copies of the original message. Please note that any views or opinions presented in this email are solely those of the author and do not necessarily represent those of the company. Finally, while the company uses virus protection, the recipient should check this email and any attachments for the presence of viruses. The company accepts no liability for any damage caused by any virus transmitted by this email.

RSVP.pdf

From: [May, Peter](#)
To: rsvp@trumporg.com
Subject: RSVP
Date: Sunday, September 01, 2013 9:04:26 AM

I regret that I cannot attend the event on September 10. Thank you for the invitation.

Peter May
Associate Regional Director - Lands, Planning, and Design
National Park Service - National Capital Region
1100 Ohio Drive SW, Washington, DC 20242
(202) 619 7025
pmay@nps.gov

RSVP for Old Post Office reception on Sept. 10..pdf

From: [Tepper, Audrey](#)
To: rsvp@trumporg.com
Subject: RSVP for Old Post Office reception on Sept. 10.
Date: Sunday, September 01, 2013 10:22:49 AM

I was unable to respond via the link you provided, but please accept this RSVP to the Old Post Office event on September, 10, 2013..."architectural and design unveiling."

Thank you for this invitation, I would love to attend.

--

Audrey T. Tepper - LEED Green Associate
Historical Architect
National Park Service
Technical Preservation Services Branch
1201 Eye Street, NW - Org. 2200
Washington, DC 20005
202-354-2027
202-371-1616 (FAX)
audrey_tepper@nps.gov

Architectural & Design Unveiling of Trump Inter....pdf

From: [Tracy L. Papp](#)
Subject: Architectural & Design Unveiling of Trump International Hotel, The Old Post Office
Date: Monday, September 09, 2013 11:51:10 AM
Attachments: [image001.png](#)
[oledata.mso](#)

We look forward to seeing you tomorrow at the architectural and design unveiling for the Trump International Hotel, The Old Post Office, Washington D.C.

The press conference will be held promptly at 9:30 AM within the MO9 Room at The Old Post Office Building at 1100 Pennsylvania Avenue, NW. The best entrance to use is Pennsylvania Avenue and we recommend arriving 20 minutes prior to the press conference start time to allow for security check-in. Immediately following the press conference will be a private reception.

Please feel free to contact me should you have any questions.

TRUMP **Tracy L. Papp**
Assistant to Lawrence Glick & David Orowitz
725 Fifth Avenue | New York, NY | 10022
p. 212.836.3206 | f. 212.836.3202
tpapp@trumporg.com | trump.com
THE TRUMP ORGANIZATION

This e-mail message, and any attachments to it, are for the sole use of the intended recipients, and may contain confidential and privileged information. Any unauthorized review, use, disclosure or distribution of this email message or its attachments is prohibited. If you are not the intended recipient, please contact the sender by reply email and destroy all copies of the original message. Please note that any views or opinions presented in this email are solely those of the author and do not necessarily represent those of the company. Finally, while the company uses virus protection, the recipient should check this email and any attachments for the presence of viruses. The company accepts no liability for any damage caused by any virus transmitted by this email.

rsvp to event tomorrow.pdf

From: [Nixon, Robin](#)
To: rsvp@trumporg.com
Subject: rsvp to event tomorrow
Date: Monday, September 09, 2013 1:28:45 PM

I will be attending with Bob Vogel, Superintendent of the National Mall and Memorial Parks; sorry for the late notice, just found out, thanks.

Robin Nixon
Chief of Partnerships
National Mall and Memorial Parks
National Park Service
900 Ohio Drive, SW
Washington, DC 20024
202-245-4710 (ofc)
202-738-7956 (cell)
robin_nixon@nps.gov

Old Post Office.pdf

From: [Stephen Dalton](#)
To: carolyn_richard@nps.gov; robin_nixon@nps.gov
Subject: Old Post Office
Date: Wednesday, September 18, 2013 6:42:44 AM

Thank you for meeting with us last week. Following up on the meeting we would like to get the names of the exhibit designers that you had mentioned work regularly with NPS and the contact at the Harper's Ferry Center. We look forward to working collaboratively on the exhibit space. Thanks.

Stephen H. Dalton, AIA

Dalton Advisory Group, LLC
3220 N Street, NW Unit 207
Washington, DC 20007
Tel 202-309-3945
Fax 202-318-0067

This e-mail message, and any attachments to it, are for the sole use of the intended recipients, and may contain confidential and privileged information. Any unauthorized review, use, disclosure or distribution of this email message or its attachments is prohibited. If you are not the intended recipient, please contact the sender by reply email and destroy all copies of the original message. Please note that any views or opinions presented in this email are solely those of the author and do not necessarily represent those of the company. Finally, while the company uses virus protection, the recipient should check this email and any attachments for the presence of viruses. The company accepts no liability for any damage caused by any virus transmitted by this email.

OPO Exhibition Design.pdf

From: [Stephen Dalton](#)
To: robin_nixon@nps.gov; carolyn_richard@nps.gov
Cc: [Brett Banks](#); daniellebreaux@turkadvisory.com
Subject: OPO Exhibition Design
Date: Tuesday, October 22, 2013 8:11:09 AM

At our meeting of Sept. 11 with GSA and the Trump team you had mentioned that NPS has some exhibition/museum designers that you work with regularly. When you can I would appreciate getting those names from you as we are getting ready to retain a consultant. Thank you.

Stephen H. Dalton, AIA

Dalton Advisory Group, LLC
3220 N Street, NW Unit 207
Washington, DC 20007
Tel 202-309-3945
Fax 202-318-0067

This e-mail message, and any attachments to it, are for the sole use of the intended recipients, and may contain confidential and privileged information. Any unauthorized review, use, disclosure or distribution of this email message or its attachments is prohibited. If you are not the intended recipient, please contact the sender by reply email and destroy all copies of the original message. Please note that any views or opinions presented in this email are solely those of the author and do not necessarily represent those of the company. Finally, while the company uses virus protection, the recipient should check this email and any attachments for the presence of viruses. The company accepts no liability for any damage caused by any virus transmitted by this email.

Meeting on Thursday.pdf

From: [David Orowitz](#)
To: robin_nixon@nps.gov
Cc: [Tracy L. Papp](#)
Subject: Meeting on Thursday
Date: Tuesday, January 14, 2014 2:58:21 PM

Robin,

Hope all is well. I figured it might be easier to try email since we have been exchanging voicemails. We were hoping to meet at 1 p.m. on Thursday (Danielle, Brett, and me) with whomever from NPS will be involved in programming the exhibition materials for the NPS space. If we get out of CFA early (which we are hopeful we will), it would be great if we could have flexibility to come earlier, since Brett and Danielle are both planning to head home immediately after our meeting.

Best,
Dave

David Orowitz
Senior Vice President, Acquisitions and Development
The Trump Organization
725 Fifth Avenue | New York, NY | 10022
p. 212.836.3252 | m. 646.315.4698 | f. 212.836.3202
dorowitz@trumporg.com | trump.com

This e-mail message, and any attachments to it, are for the sole use of the intended recipients, and may contain confidential and privileged information. Any unauthorized review, use, disclosure or distribution of this email message or its attachments is prohibited. If you are not the intended recipient, please contact the sender by reply email and destroy all copies of the original message. Please note that any views or opinions presented in this email are solely those of the author and do not necessarily represent those of the company. Finally, while the company uses virus protection, the recipient should check this email and any attachments for the presence of viruses. The company accepts no liability for any damage caused by any virus transmitted by this email.

RE_ Meeting on Thursday.pdf

From: [David Orowitz](#)
To: [Nixon, Robin](#)
Cc: [Tracy L. Papp](#)
Subject: RE: Meeting on Thursday
Date: Wednesday, January 15, 2014 6:18:08 AM

Great. Thanks, Robin. Where at your building should we meet?

David Orowitz

Senior Vice President, Acquisitions and Development
The Trump Organization
725 Fifth Avenue | New York, NY | 10022
p. 212.836.3252 | m. 646.315.4698 | f. 212.836.3202
dorowitz@trumporg.com | trump.com

From: Nixon, Robin [mailto:robin_nixon@nps.gov]
Sent: Wednesday, January 15, 2014 8:11 AM
To: David Orowitz
Subject: Re: Meeting on Thursday

Dave, we are all confirmed on our end for Thursday at 1pm, and yes, it will work best for us to have the meeting here, thanks. NPS participants include:

Robin Nixon, Chief of Partnerships
Carolyn Richard, Chief of Interpretation & Education
Rosanna Weltzin, Deputy Chief of Interp & Education
Laura Cohen, Interpretive Media Specialist

See you Thursday. Let me know if you have any questions. Robin

Robin Nixon
Chief of Partnerships
National Mall and Memorial Parks
National Park Service
900 Ohio Drive, SW
Washington, DC 20024
202-245-4710 (ofc)
202-738-7956 (cell)
robin_nixon@nps.gov

On Wed, Jan 15, 2014 at 6:20 AM, David Orowitz <dorowitz@trumporg.com> wrote:
If that is most convenient for your team, it is fine for us. If not, we could also meet at the Old Post Office. Always good to be in the space, but not critical for this meeting.

Once you let me know location and participants, Tracy and I can send an invite.

Sent from my Verizon Wireless 4G LTE smartphone

----- Original message -----
From: "Nixon, Robin"

Date:01/14/2014 4:44 PM (GMT-05:00)
To: David Orowitz
Subject: Re: Meeting on Thursday

Dave, we are going to confirm thursday at 1. we are not positive about one of our staff, but the Chief of Interpretation/Education and I will be available. You said we could meet here at 900 Ohio, correct?

Robin Nixon
Chief of Partnerships
National Mall and Memorial Parks
National Park Service
900 Ohio Drive, SW
Washington, DC 20024
202-245-4710 (ofc)
202-738-7956 (cell)
robin_nixon@nps.gov

On Tue, Jan 14, 2014 at 4:09 PM, David Orowitz <dorowitz@trumporg.com> wrote:
Great. Thanks, Robin.

David Orowitz
Senior Vice President, Acquisitions and Development
The Trump Organization
725 Fifth Avenue | New York, NY | 10022
p. 212.836.3252 | m. 646.315.4698 | f. 212.836.3202
dorowitz@trumporg.com | trump.com

From: Nixon, Robin [mailto:robin_nixon@nps.gov]
Sent: Tuesday, January 14, 2014 4:01 PM
To: David Orowitz
Cc: Tracy L. Papp; Carolyn Richard
Subject: Re: Meeting on Thursday

Dave, I will check with folks here for availability at 1pm on thursday. We would have to play it by ear as far as coming any earlier--people are generally booked pretty tightly, but if you check in when you are done at CFA, we'll let you know if earlier can work for everyone here. Carolyn, does this time work for you and others who should be at the meeting?

Robin Nixon
Chief of Partnerships
National Mall and Memorial Parks
National Park Service
900 Ohio Drive, SW
Washington, DC 20024
202-245-4710 (ofc)
202-738-7956 (cell)
robin_nixon@nps.gov

On Tue, Jan 14, 2014 at 3:17 PM, David Orowitz <dorowitz@trumporg.com> wrote:
Robin,

Hope all is well. I figured it might be easier to try email since we have been exchanging voicemails. We were hoping to meet at 1 p.m. on Thursday (Danielle, Brett, and me) with whomever from NPS will be involved in programming the exhibition materials for the NPS space. If we get out of CFA early (which we are hopeful we will), it would be great if we could have flexibility to come earlier, since Brett and Danielle are both planning to head home immediately after our meeting.

Best,
Dave

David Orowitz
Senior Vice President, Acquisitions and Development
The Trump Organization
725 Fifth Avenue | New York, NY | 10022
p. 212.836.3252 | m. 646.315.4698 | f. 212.836.3202
dorowitz@trumporg.com | trump.com

This e-mail message, and any attachments to it, are for the sole use of the intended recipients, and may contain confidential and privileged information. Any unauthorized review, use, disclosure or distribution of this email message or its attachments is prohibited. If you are not the intended recipient, please contact the sender by reply email and destroy all copies of the original message. Please note that any views or opinions presented in this email are solely those of the author and do not necessarily represent those of the company. Finally, while the company uses virus protection, the recipient should check this email and any attachments for the presence of viruses. The company accepts no liability for any damage caused by any virus transmitted by this email.

Re_ OPO_ Curb-cut Design Coordination.pdf

From: Perry, James
To: daniellebreaux@turkadvisory.com
Cc: [Brett Banks - WPT-C](#); [Stephen Dalton](#); [David Orowitz](#); [Andrew Weiss \(aweiss@trumporg.com\)](#); [Suzy Hill - WPDB](#); [Nancy Witherell - WPDA](#); [Danielle Breaux - WPS-C](#); [Jeff Gowen](#); [Sean Kennealy](#)
Subject: Re: OPO: Curb-cut Design Coordination
Date: Wednesday, January 15, 2014 6:21:00 AM

Thank you, Danielle. For NPS (National Mall and Memorial Parks), Jeff Gowen and Sean Kennealy from our Professional Services division will provide coordination for plans and construction. We look forward to meeting and discussing this aspect of the project.

Sincerely,

James Perry
Chief, Resource Management
National Mall and Memorial Parks
900 Ohio Drive SW
Washington, DC 20024-2000
(202) 245-4711

On Tue, Jan 14, 2014 at 4:10 PM, daniellebreaux@turkadvisory.com <daniellebreaux@turkadvisory.com> wrote:

James –

Happy Belated New Year! We wanted to follow-up with you on the coordination efforts and any approval process associated with the OPO 11th Street Curb-cut design for the portion of Pennsylvania Avenue that will remain under NPS jurisdiction. We are hoping to finalize the transfer of the curb cut property and the triangular portion of the plaza in front of the building within the next few weeks so the only components that we need to coordinate with you on are more related to things that would occur to the land that would remain under NPS jurisdiction (the sidewalk). As I have noted previously, DDOT is only concerned about the actual signalization and safety of the intersection leaving any other coordination and potential approval to NPS.

Attached you will find three items:

1. **Penn Ave Proposed Drawings:** These plans C-1 shows the existing condition now, C-2 shows what we are proposing to relocate and remove in order to accomplish the work and C-3 shows the new curb cut with an enlarged detail showing the work at a larger scale.
2. **NPS Tree Preservation:** This plan depicts the tree preservation and site removal plan.
3. **NPS Curb Cut Diagram:** This is the simplified plan which depicts in blue text elements

of work occurring on land under NPS jurisdiction that we need to coordinate with you on for any NPS approval. These elements are:

- a. The sidewalk depressions to the new curb cut (the land coming to GSA jurisdiction is for curb to curb of the curb cut only) and the actual curb of the curb cut.
- b. Removal of trees and light poles to accommodate for the new curb cut area
- c. Relocation of the DDOT signal box and addition of traffic signals onto land remaining under NPS jurisdiction

We would like to set up a meeting with GSA, Trump's design team and the appropriate persons from NPS to review and discuss the attached information in order to address any areas of concern or questions NPS may have. Please let us know who we should include in this discussion and I will gladly set up the meeting.

Thank you in advance for your continued support and assistance with this project. Please do not hesitate to contact me any questions.

Danielle

Danielle Breaux

Office of Planning & Design Quality

Tel 202.288.1298

Em daniellebreaux@turkadvisor.com

Exhibition Programming.pdf

From: dorowitz@trumporg.com on behalf of [David Orowitz](#)
To: "[Danielle Breaux](#)"; "[Brett Banks](#)"; robin_nixon@nps.gov; [Carolyn Richard \(carolyn_richard@nps.gov\)](mailto:Carolyn_Richard@nps.gov)
Subject: Exhibition Programming

When: Thursday, January 16, 2014 1:00 PM-2:00 PM (UTC-05:00) Eastern Time (US & Canada).
Where: National Park Service-900 Ohio Drive, SW

Note: The GMT offset above does not reflect daylight saving time adjustments.

~~*~*~*~*~*~*~*~*

Robin Nixon, Chief of Partnerships
Carolyn Richard, Chief of Interpretation & Education
Rosanna Weltzin, Deputy Chief of Interp & Education
Laura Cohen, Interpretive Media Specialist

This e-mail message, and any attachments to it, are for the sole use of the intended recipients, and may contain confidential and privileged information. Any unauthorized review, use, disclosure or distribution of this email message or its attachments is prohibited. If you are not the intended recipient, please contact the sender by reply email and destroy all copies of the original message. Please note that any views or opinions presented in this email are solely those of the author and do not necessarily represent those of the company. Finally, while the company uses virus protection, the recipient should check this email and any attachments for the presence of viruses. The company accepts no liability for any damage caused by any virus transmitted by this email.

Accepted_ Exhibition Programming @ Thu Jan 16,pdf

From: [Google Calendar](#) on behalf of [Carolyn Richard](#)
To: [David Orowitz](#)
Subject: Accepted: Exhibition Programming @ Thu Jan 16, 2014 1pm - 2pm (carolyn_richard@nps.gov)
Attachments: [invite.ics](#)

Carolyn Richard has accepted this invitation.

Exhibition Programming

When: Thursday, January 16, 2014 1:00 PM-2:00 PM (UTC-05:00) Eastern Time (US & Canada).

Where: National Park Service-900 Ohio Drive, SW

Note: The GMT offset above does not reflect daylight saving time adjustments.

~~*~*~*~*~*~*~*~*

Robin Nixon, Chief of Partnerships

Carolyn Richard, Chief of Interpretation & Education

Rosanna Weltzin, Deputy Chief of Interp & Education

Laura Cohen, Interpretive Media Specialist

When Thu Jan 16, 2014 1pm – 2pm Eastern Time

Where National Park Service-900 Ohio Drive, SW (HYPERLINK "<http://maps.google.com/maps?q=National+Park+Service-900+Ohio+Drive,+SW&hl=en>" map)

Calendar carolyn_richard@nps.gov

Who • David Orowitz - organizer

• Carolyn Richard - creator

• 'Danielle Breaux'

• robin_nixon@nps.gov

• 'Brett Banks'

Invitation from HYPERLINK "<https://www.google.com/calendar/>" Google Calendar

You are receiving this courtesy email at the account dorowitz@trumporg.com because you are an attendee of this event.

To stop receiving future notifications for this event, decline this event. Alternatively you can sign up for a Google account at <https://www.google.com/calendar/> and control your notification settings for your entire calendar.

Exhibition Programming Meeting.pdf

From: [Tracy L. Papp](#)
To: robin_nixon@nps.gov
Cc: [David Orowitz](#)
Subject: Exhibition Programming Meeting
Date: Wednesday, January 15, 2014 7:44:10 AM
Attachments: [image001.png](#)
[oledata.mso](#)

Hi Robin,

I hope you are well. I just sent out an invitation to the meeting tomorrow at 1:00pm. Can you forward the meeting request to the other members of your team?

Thanks,

Tracy

T R U M P **Tracy L. Papp**
Assistant to Lawrence Glick & David Orowitz
725 Fifth Avenue | New York, NY | 10022
THE TRUMP ORGANIZATION p. 212.836.3206 | f. 212.836.3202
tpapp@trumporg.com | trump.com

This e-mail message, and any attachments to it, are for the sole use of the intended recipients, and may contain confidential and privileged information. Any unauthorized review, use, disclosure or distribution of this email message or its attachments is prohibited. If you are not the intended recipient, please contact the sender by reply email and destroy all copies of the original message. Please note that any views or opinions presented in this email are solely those of the author and do not necessarily represent those of the company. Finally, while the company uses virus protection, the recipient should check this email and any attachments for the presence of viruses. The company accepts no liability for any damage caused by any virus transmitted by this email.

Accepted_ Exhibition Programming @ Thu Jan 16, ...(1).pdf

From: [Google Calendar](#) on behalf of [Robin Nixon](#)
To: [David Orowitz](#)
Subject: Accepted: Exhibition Programming @ Thu Jan 16, 2014 1pm - 2pm (robin_nixon@nps.gov)
Attachments: [invite.ics](#)

Robin Nixon has accepted this invitation.

Exhibition Programming

When: Thursday, January 16, 2014 1:00 PM-2:00 PM (UTC-05:00) Eastern Time (US & Canada).

Where: National Park Service-900 Ohio Drive, SW

Note: The GMT offset above does not reflect daylight saving time adjustments.

~~*~*~*~*~*~*~*~*

Robin Nixon, Chief of Partnerships

Carolyn Richard, Chief of Interpretation & Education

Rosanna Weltzin, Deputy Chief of Interp & Education

Laura Cohen, Interpretive Media Specialist

When Thu Jan 16, 2014 1pm – 2pm Eastern Time

Where National Park Service-900 Ohio Drive, SW (HYPERLINK "<http://maps.google.com/maps?q=National+Park+Service-900+Ohio+Drive,+SW&hl=en>" map)

Calendar robin_nixon@nps.gov

Who • David Orowitz - organizer

• Robin Nixon - creator

• 'Danielle Breaux'

• Carolyn Richard (carolyn_richard@nps.gov)

• 'Brett Banks'

Invitation from HYPERLINK "<https://www.google.com/calendar/>" Google Calendar

You are receiving this courtesy email at the account dorowitz@trumporg.com because you are an attendee of this event.

To stop receiving future notifications for this event, decline this event. Alternatively you can sign up for a Google account at <https://www.google.com/calendar/> and control your notification settings for your entire calendar.

Cancel 1 pm.pdf

From: [David Orowitz](#)
To: [Robin Nixon](#)
Cc: [Carolyn Richard](#)
Subject: Cancel 1 pm
Date: Thursday, January 16, 2014 10:01:39 AM

Robin

I just left you a vm. I am very sorry but we are still at CFA. We thought we would present at 10 but they are still reviewing another project. It looks like we will need to reschedule. I will be in contact to try to find a time that is convenient for you.

Best
Dave

Sent from my Verizon Wireless 4G LTE smartphone

This e-mail message, and any attachments to it, are for the sole use of the intended recipients, and may contain confidential and privileged information. Any unauthorized review, use, disclosure or distribution of this email message or its attachments is prohibited. If you are not the intended recipient, please contact the sender by reply email and destroy all copies of the original message. Please note that any views or opinions presented in this email are solely those of the author and do not necessarily represent those of the company. Finally, while the company uses virus protection, the recipient should check this email and any attachments for the presence of viruses. The company accepts no liability for any damage caused by any virus transmitted by this email.

Canceled_ Exhibition Programming.pdf

From: dorowitz@trumporg.com on behalf of [David Orowitz](#)
To: "[Danielle Breaux](#)"; "[Brett Banks](#)"; "robin_nixon@nps.gov"; "[Carolyn Richard \(carolyn_richard@nps.gov\)](mailto:Carolyn_Richard@nps.gov)"
Subject: Canceled: Exhibition Programming
Importance: High

When: Thursday, January 16, 2014 1:00 PM-2:00 PM (UTC-05:00) Eastern Time (US & Canada).
Where: National Park Service-900 Ohio Drive, SW

Note: The GMT offset above does not reflect daylight saving time adjustments.

~~*~*~*~*~*~*~*~*

Robin Nixon, Chief of Partnerships
Carolyn Richard, Chief of Interpretation & Education
Rosanna Weltzin, Deputy Chief of Interp & Education
Laura Cohen, Interpretive Media Specialist

This e-mail message, and any attachments to it, are for the sole use of the intended recipients, and may contain confidential and privileged information. Any unauthorized review, use, disclosure or distribution of this email message or its attachments is prohibited. If you are not the intended recipient, please contact the sender by reply email and destroy all copies of the original message. Please note that any views or opinions presented in this email are solely those of the author and do not necessarily represent those of the company. Finally, while the company uses virus protection, the recipient should check this email and any attachments for the presence of viruses. The company accepts no liability for any damage caused by any virus transmitted by this email.

RE_Conference Call.pdf

From: [Tracy L. Papp](#)
To: [Nixon, Robin](#)
Subject: RE: Conference Call
Date: Wednesday, January 22, 2014 8:34:36 AM

Hi Robin,

No problem! Dave will be out off the office starting on Friday. Is there any way tomorrow can work? Otherwise he will be available when he returns next week on the 30th.

Thanks,

Tracy

From: Nixon, Robin [mailto:robin_nixon@nps.gov]
Sent: Wednesday, January 22, 2014 10:23 AM
To: Tracy L. Papp
Subject: Re: Conference Call

sorry, Tracy--Monday was a holiday for us, and yesterday a snow day. I am available on Friday if Dave has time available. I will need to check with my colleagues for their availability, but if you have times on Friday I will check with them. Robin

Robin Nixon
Chief of Partnerships
National Mall and Memorial Parks
National Park Service
900 Ohio Drive, SW
Washington, DC 20024
202-245-4710 (ofc)
202-738-7956 (cell)
robin_nixon@nps.gov

On Wed, Jan 22, 2014 at 10:22 AM, Tracy L. Papp <tpapp@trumporg.com> wrote:
Hi Robin,

I just wanted to follow up on my email from Monday. Are you available this week for a call with Dave Orowitz? Thanks.

Best,

Tracy

From: Tracy L. Papp
Sent: Monday, January 20, 2014 3:48 PM
To: Nixon, Robin

Subject: Conference Call

Hi Robin,

I hope you're well. Dave asked me to coordinate a conference call this week. Can you let me know what date/time will work best for your team? Thanks.

Best,
Tracy

Sent from my Verizon Wireless 4G LTE Smartphone

----- Original message -----

From: "Nixon, Robin"
Date: 01/14/2014 4:02 PM (GMT-05:00)
To: David Orowitz
Cc: "Tracy L. Papp", Carolyn Richard
Subject: Re: Meeting on Thursday

Dave, I will check with folks here for availability at 1pm on thursday. We would have to play it by ear as far as coming any earlier--people are generally booked pretty tightly, but if you check in when you are done at CFA, we'll let you know if earlier can work for everyone here. Carolyn, does this time work for you and others who should be at the meeting?

Robin Nixon
Chief of Partnerships
National Mall and Memorial Parks
National Park Service
900 Ohio Drive, SW
Washington, DC 20024
202-245-4710 (ofc)
202-738-7956 (cell)
robin_nixon@nps.gov

On Tue, Jan 14, 2014 at 3:17 PM, David Orowitz <dorowitz@trumporg.com> wrote:
Robin,

Hope all is well. I figured it might be easier to try email since we have been exchanging voicemails. We were hoping to meet at 1 p.m. on Thursday (Danielle, Brett, and me) with whomever from NPS will be involved in programming the exhibition materials for the NPS space. If we get out of CFA early (which we are hopeful we will), it would be great if we could have flexibility to come earlier, since Brett and Danielle are both planning to head home immediately after our meeting.

Best,
Dave

David Orowitz

Senior Vice President, Acquisitions and Development
The Trump Organization
725 Fifth Avenue | New York, NY | 10022
p. 212.836.3252 | m. 646.315.4698 | f. 212.836.3202
dorowitz@trumporg.com | trump.com

This e-mail message, and any attachments to it, are for the sole use of the intended recipients, and may contain confidential and privileged information. Any unauthorized review, use, disclosure or distribution of this email message or its attachments is prohibited. If you are not the intended recipient, please contact the sender by reply email and destroy all copies of the original message. Please note that any views or opinions presented in this email are solely those of the author and do not necessarily represent those of the company. Finally, while the company uses virus protection, the recipient should check this email and any attachments for the presence of viruses. The company accepts no liability for any damage caused by any virus transmitted by this email.

RE_Conference Call(1).pdf

From: [Tracy L. Papp](#)
To: [Nixon, Robin](#)
Subject: RE: Conference Call
Date: Wednesday, January 22, 2014 2:10:09 PM

That's completely fine Robin! One change though. Could we make it Friday the 31st? Dave may stay in California one extra day. Thanks.

From: Nixon, Robin [mailto:robin_nixon@nps.gov]
Sent: Wednesday, January 22, 2014 4:08 PM
To: Tracy L. Papp
Subject: Re: Conference Call

it will have to be the 30th, sorry! can't get people here tomorrow--everyone is catching up from the snow day!

Robin Nixon
Chief of Partnerships
National Mall and Memorial Parks
National Park Service
900 Ohio Drive, SW
Washington, DC 20024
202-245-4710 (ofc)
202-738-7956 (cell)
robin_nixon@nps.gov

On Wed, Jan 22, 2014 at 10:35 AM, Tracy L. Papp <tpapp@trumporg.com> wrote:
Hi Robin,

No problem! Dave will be out off the office starting on Friday. Is there any way tomorrow can work? Otherwise he will be available when he returns next week on the 30th.

Thanks,

Tracy

From: Nixon, Robin [mailto:robin_nixon@nps.gov]
Sent: Wednesday, January 22, 2014 10:23 AM
To: Tracy L. Papp
Subject: Re: Conference Call

sorry, Tracy--Monday was a holiday for us, and yesterday a snow day. I am available on Friday if Dave has time available. I will need to check with my colleagues for their availability, but if you have times on Friday I will check with them. Robin

Robin Nixon
Chief of Partnerships

National Mall and Memorial Parks
National Park Service
900 Ohio Drive, SW
Washington, DC 20024
202-245-4710 (ofc)
202-738-7956 (cell)
robin_nixon@nps.gov

On Wed, Jan 22, 2014 at 10:22 AM, Tracy L. Papp <tpapp@trumporg.com> wrote:
Hi Robin,

I just wanted to follow up on my email from Monday. Are you available this week for a call with Dave Orowitz? Thanks.

Best,

Tracy

From: Tracy L. Papp
Sent: Monday, January 20, 2014 3:48 PM
To: Nixon, Robin
Subject: Conference Call

Hi Robin,
I hope you're well. Dave asked me to coordinate a conference call this week. Can you let me know what date/time will work best for your team? Thanks.
Best,
Tracy

Sent from my Verizon Wireless 4G LTE Smartphone

----- Original message -----
From: "Nixon, Robin"
Date: 01/14/2014 4:02 PM (GMT-05:00)
To: David Orowitz
Cc: "Tracy L. Papp", Carolyn Richard
Subject: Re: Meeting on Thursday

Dave, I will check with folks here for availability at 1pm on Thursday. We would have to play it by ear as far as coming any earlier--people are generally booked pretty tightly, but if you check in when you are done at CFA, we'll let you know if earlier can work for everyone here. Carolyn, does this time work for you and others who should be at the meeting?

Robin Nixon
Chief of Partnerships

National Mall and Memorial Parks
National Park Service
900 Ohio Drive, SW
Washington, DC 20024
202-245-4710 (ofc)
202-738-7956 (cell)
robin_nixon@nps.gov

On Tue, Jan 14, 2014 at 3:17 PM, David Orowitz <dorowitz@trumporg.com> wrote:
Robin,

Hope all is well. I figured it might be easier to try email since we have been exchanging voicemails. We were hoping to meet at 1 p.m. on Thursday (Danielle, Brett, and me) with whomever from NPS will be involved in programming the exhibition materials for the NPS space. If we get out of CFA early (which we are hopeful we will), it would be great if we could have flexibility to come earlier, since Brett and Danielle are both planning to head home immediately after our meeting.

Best,
Dave

David Orowitz
Senior Vice President, Acquisitions and Development
The Trump Organization
725 Fifth Avenue | New York, NY | 10022
p. 212.836.3252 | m. 646.315.4698 | f. 212.836.3202
dorowitz@trumporg.com | trump.com

This e-mail message, and any attachments to it, are for the sole use of the intended recipients, and may contain confidential and privileged information. Any unauthorized review, use, disclosure or distribution of this email message or its attachments is prohibited. If you are not the intended recipient, please contact the sender by reply email and destroy all copies of the original message. Please note that any views or opinions presented in this email are solely those of the author and do not necessarily represent those of the company. Finally, while the company uses virus protection, the recipient should check this email and any attachments for the presence of viruses. The company accepts no liability for any damage caused by any virus transmitted by this email.

Re_Conference Call_1.pdf

From: [Nixon, Robin](#)
To: [Tracy L. Papp](#)
Subject: Re: Conference Call
Date: Tuesday, January 28, 2014 9:19:48 AM

Sorry, Tracy--lost track of rescheduling this! It looks like Tuesday afternoon is the best time, if that works. Sometime between 1 & 3pm is open--let me know if that works. If it doesn't, can you send me some proposed times & we'll try to reschedule around them? Thanks, Robin

Robin Nixon
Chief of Partnerships
National Mall and Memorial Parks
National Park Service
900 Ohio Drive, SW
Washington, DC 20024
202-245-4710 (ofc)
202-738-7956 (cell)
robin_nixon@nps.gov

On Mon, Jan 27, 2014 at 1:47 PM, Tracy L. Papp <tpapp@trumporg.com> wrote:

Hi Robin,

I hope that you had a nice weekend. I just wanted to follow up on the conference call next week. Can you let me know what day/time works best for you? Thank you.

Best,

Tracy

From: Nixon, Robin [mailto:robin_nixon@nps.gov]
Sent: Wednesday, January 22, 2014 4:20 PM
To: Tracy L. Papp
Subject: Re: Conference Call

unfortunately, I will be out of the office on the 31st. aim for early the next week?

Robin Nixon

Chief of Partnerships

National Mall and Memorial Parks

National Park Service

900 Ohio Drive, SW

Washington, DC 20024

202-245-4710 (ofc)

202-738-7956 (cell)

robin_nixon@nps.gov

On Wed, Jan 22, 2014 at 4:11 PM, Tracy L. Papp <tpapp@trumporg.com> wrote:

That's completely fine Robin! One change though. Could we make it Friday the 31st? Dave may stay in California one extra day. Thanks.

From: Nixon, Robin [mailto:robin_nixon@nps.gov]
Sent: Wednesday, January 22, 2014 4:08 PM
To: Tracy L. Papp
Subject: Re: Conference Call

it will have to be the 30th, sorry! can't get people here tomorrow--everyone is catching up from the snow day!

Robin Nixon

Chief of Partnerships

National Mall and Memorial Parks

National Park Service

900 Ohio Drive, SW
Washington, DC 20024
202-245-4710 (ofc)
202-738-7956 (cell)
robin_nixon@nps.gov

On Wed, Jan 22, 2014 at 10:35 AM, Tracy L. Papp <tpapp@trumporg.com> wrote:

Hi Robin,

No problem! Dave will be out off the office starting on Friday. Is there any way tomorrow can work? Otherwise he will be available when he returns next week on the 30th.

Thanks,

Tracy

From: Nixon, Robin [mailto:robin_nixon@nps.gov]
Sent: Wednesday, January 22, 2014 10:23 AM
To: Tracy L. Papp
Subject: Re: Conference Call

sorry, Tracy--Monday was a holiday for us, and yesterday a snow day. I am available on Friday if Dave has time available. I will need to check with my colleagues for their availability, but if you have times on Friday I will check with them. Robin

Robin Nixon
Chief of Partnerships

National Mall and Memorial Parks

National Park Service

900 Ohio Drive, SW

Washington, DC 20024

202-245-4710 (ofc)

202-738-7956 (cell)

robin_nixon@nps.gov

On Wed, Jan 22, 2014 at 10:22 AM, Tracy L. Papp <tpapp@trumporg.com> wrote:

Hi Robin,

I just wanted to follow up on my email from Monday. Are you available this week for a call with Dave Orowitz? Thanks.

Best,

Tracy

From: Tracy L. Papp
Sent: Monday, January 20, 2014 3:48 PM
To: Nixon, Robin
Subject: Conference Call

Hi Robin,

I hope you're well. Dave asked me to coordinate a conference call this week. Can you let me know what date/time will work best for your team? Thanks.

Best,

Tracy

Sent from my Verizon Wireless 4G LTE Smartphone

----- Original message -----

From: "Nixon, Robin"

Date: 01/14/2014 4:02 PM (GMT-05:00)

To: David Orowitz

Cc: "Tracy L. Papp", Carolyn Richard

Subject: Re: Meeting on Thursday

Dave, I will check with folks here for availability at 1pm on thursday. We would have to play it by ear as far as coming any earlier--people are generally booked pretty tightly, but if you check in when you are done at CFA, we'll let you know if earlier can work for everyone here. Carolyn, does this time work for you and others who should be at the meeting?

Robin Nixon

Chief of Partnerships

National Mall and Memorial Parks

National Park Service

900 Ohio Drive, SW

Washington, DC 20024

202-245-4710 (ofc)

202-738-7956 (cell)

robin_nixon@nps.gov

On Tue, Jan 14, 2014 at 3:17 PM, David Orowitz <dorowitz@trumporg.com> wrote:

Robin,

Hope all is well. I figured it might be easier to try email since we have been exchanging voicemails. We were hoping to meet at 1 p.m. on Thursday (Danielle, Brett, and me) with whomever from NPS will be involved in programming the exhibition materials for the NPS space. If we get out of CFA early (which we are hopeful we will), it would be great if we could have flexibility to come earlier, since Brett and Danielle are both planning to head home immediately after our meeting.

Best,

Dave

David Orowitz
Senior Vice President, Acquisitions and Development

The Trump Organization

725 Fifth Avenue | New York, NY | 10022
p. 212.836.3252 | m. 646.315.4698 | f. 212.836.3202

dorowitz@trumporg.com | trump.com

This e-mail message, and any attachments to it, are for the sole use of the intended recipients, and may contain confidential and privileged information. Any unauthorized review, use, disclosure or distribution of this email message or its attachments is prohibited. If you are not the intended recipient, please contact the sender by reply email and destroy all copies of the original message. Please note that any views or opinions presented in this email are solely those of the author and do not necessarily represent those of the company. Finally, while the company uses virus protection, the recipient should check this email and any attachments for the presence of viruses. The company accepts no liability for any damage caused by any virus transmitted by this email.

Exhibition Programming(1).pdf

From: dorowitz@trumporg.com on behalf of [David Orowitz](#)
To: [Nixon, Robin](#); "[Carolyn Richard \(carolyn_richard@nps.gov\)](mailto:Carolyn Richard (carolyn_richard@nps.gov))"; "[Brett Banks](#)"; daniellebreaux@turkadvisory.com
Subject: Exhibition Programming

When: Tuesday, February 04, 2014 2:00 PM-3:00 PM (UTC-05:00) Eastern Time (US & Canada).
Where: Please use dial in below

Note: The GMT offset above does not reflect daylight saving time adjustments.

~~*~*~*~*~*~*~*~*

Domestic: Not Responsive
International: Not Responsive
Access Code: Not Responsive
Host Code: Not Responsive

This e-mail message, and any attachments to it, are for the sole use of the intended recipients, and may contain confidential and privileged information. Any unauthorized review, use, disclosure or distribution of this email message or its attachments is prohibited. If you are not the intended recipient, please contact the sender by reply email and destroy all copies of the original message. Please note that any views or opinions presented in this email are solely those of the author and do not necessarily represent those of the company. Finally, while the company uses virus protection, the recipient should check this email and any attachments for the presence of viruses. The company accepts no liability for any damage caused by any virus transmitted by this email.

RE_Conference Call(2).pdf

From: [Tracy L. Papp](#)
To: [Nixon, Robin](#)
Subject: RE: Conference Call
Date: Tuesday, January 28, 2014 12:26:03 PM

Hi Robin,

I just sent out an invitation for a 2:00pm call on Tuesday. Thanks again!

Best,

Tracy

From: Nixon, Robin [mailto:robin_nixon@nps.gov]
Sent: Tuesday, January 28, 2014 11:19 AM
To: Tracy L. Papp
Subject: Re: Conference Call

Sorry, Tracy--lost track of rescheduling this! It looks like Tuesday afternoon is the best time, if that works. Sometime between 1 & 3pm is open--let me know if that works. If it doesn't, can you send me some proposed times & we'll try to reschedule around them? Thanks, Robin

Robin Nixon
Chief of Partnerships
National Mall and Memorial Parks
National Park Service
900 Ohio Drive, SW
Washington, DC 20024
202-245-4710 (ofc)
202-738-7956 (cell)
robin_nixon@nps.gov

On Mon, Jan 27, 2014 at 1:47 PM, Tracy L. Papp <tpapp@trumporg.com> wrote:

Hi Robin,

I hope that you had a nice weekend. I just wanted to follow up on the conference call next week. Can you let me know what day/time works best for you? Thank you.

Best,

Tracy

From: Nixon, Robin [mailto:robin_nixon@nps.gov]
Sent: Wednesday, January 22, 2014 4:20 PM
To: Tracy L. Papp
Subject: Re: Conference Call

unfortunately, I will be out of the office on the 31st. aim for early the next week?

Robin Nixon
Chief of Partnerships
National Mall and Memorial Parks
National Park Service
900 Ohio Drive, SW
Washington, DC 20024
202-245-4710 (ofc)
202-738-7956 (cell)
robin_nixon@nps.gov

On Wed, Jan 22, 2014 at 4:11 PM, Tracy L. Papp <tpapp@trumporg.com> wrote:
That's completely fine Robin! One change though. Could we make it Friday the 31st? Dave may stay in California one extra day. Thanks.

From: Nixon, Robin [mailto:robin_nixon@nps.gov]
Sent: Wednesday, January 22, 2014 4:08 PM
To: Tracy L. Papp
Subject: Re: Conference Call

it will have to be the 30th, sorry! can't get people here tomorrow--everyone is catching up from the snow day!

Robin Nixon
Chief of Partnerships
National Mall and Memorial Parks
National Park Service
900 Ohio Drive, SW
Washington, DC 20024
202-245-4710 (ofc)
202-738-7956 (cell)
robin_nixon@nps.gov

On Wed, Jan 22, 2014 at 10:35 AM, Tracy L. Papp <tpapp@trumporg.com> wrote:
Hi Robin,

No problem! Dave will be out off the office starting on Friday. Is there any way tomorrow can work? Otherwise he will be available when he returns next week on the 30th.

Thanks,

Tracy

From: Nixon, Robin [mailto:robin_nixon@nps.gov]
Sent: Wednesday, January 22, 2014 10:23 AM
To: Tracy L. Papp
Subject: Re: Conference Call

sorry, Tracy--Monday was a holiday for us, and yesterday a snow day. I am available on Friday if Dave has time available. I will need to check with my colleagues for their availability, but if you have times on Friday I will check with them. Robin

Robin Nixon
Chief of Partnerships
National Mall and Memorial Parks
National Park Service
900 Ohio Drive, SW
Washington, DC 20024
202-245-4710 (ofc)
202-738-7956 (cell)
robin_nixon@nps.gov

On Wed, Jan 22, 2014 at 10:22 AM, Tracy L. Papp <tpapp@trumporg.com> wrote:
Hi Robin,

I just wanted to follow up on my email from Monday. Are you available this week for a call with Dave Orowitz? Thanks.

Best,

Tracy

From: Tracy L. Papp
Sent: Monday, January 20, 2014 3:48 PM
To: Nixon, Robin
Subject: Conference Call

Hi Robin,
I hope you're well. Dave asked me to coordinate a conference call this week. Can you let me know what date/time will work best for your team? Thanks.

Best,
Tracy

Sent from my Verizon Wireless 4G LTE Smartphone

----- Original message -----

From: "Nixon, Robin"
Date: 01/14/2014 4:02 PM (GMT-05:00)
To: David Orowitz
Cc: "Tracy L. Papp", Carolyn Richard
Subject: Re: Meeting on Thursday

Dave, I will check with folks here for availability at 1pm on thursday. We would have to play it by ear as far as coming any earlier--people are generally booked pretty tightly, but if you check in when you are done at CFA, we'll let you know if earlier can work for everyone here. Carolyn, does this time work for you and others who should be at the meeting?

Robin Nixon
Chief of Partnerships
National Mall and Memorial Parks
National Park Service
900 Ohio Drive, SW
Washington, DC 20024
202-245-4710 (ofc)
202-738-7956 (cell)
robin_nixon@nps.gov

On Tue, Jan 14, 2014 at 3:17 PM, David Orowitz <dorowitz@trumporg.com> wrote:
Robin,

Hope all is well. I figured it might be easier to try email since we have been exchanging voicemails. We were hoping to meet at 1 p.m. on Thursday (Danielle, Brett, and me) with whomever from NPS will be involved in programming the exhibition materials for the NPS space. If we get out of CFA early (which we are hopeful we will), it would be great if we could have flexibility to come earlier, since Brett and Danielle are both planning to head home immediately after our meeting.

Best,
Dave

David Orowitz
Senior Vice President, Acquisitions and Development
The Trump Organization
725 Fifth Avenue | New York, NY | 10022
p. 212.836.3252 | m. 646.315.4698 | f. 212.836.3202
dorowitz@trumporg.com | trump.com

This e-mail message, and any attachments to it, are for the sole use of the intended recipients, and may contain confidential and privileged information. Any unauthorized review, use, disclosure or distribution of this email message or its attachments is prohibited. If you are not the intended recipient, please contact the sender by reply email and destroy all copies of the original message. Please note that any views or opinions presented in this email are solely those of the author and do not necessarily represent those of the company. Finally, while the company uses virus protection, the recipient should check this email and any attachments for the presence of viruses. The company accepts no liability for any damage caused by any virus

transmitted by this email.

Accepted_ Exhibition Programming @ Tue Feb 4, 2....pdf

Accepted_ Exhibition Programming @ Tue Feb 4, 2... (1).pdf

RE_ Lost Sunglasses.pdf

From: [Joshua Seidner](#)
To: [Tepper, Audrey](#)
Cc: [Katherine Bramhall](#)
Subject: RE: Lost Sunglasses
Date: Wednesday, February 12, 2014 9:23:41 AM
Attachments: [image002.png](#)
[image003.png](#)

No problem!!

Best regards,
Josh



Joshua D. Seidner

Vice President, Design & Development
725 Fifth Avenue | New York, NY | 10022
p. 212.836.3231 | m. 908.963.4097
jseidner@trumporg.com | trump.com

From: Tepper, Audrey [mailto:audrey_tepper@nps.gov]
Sent: Wednesday, February 12, 2014 11:23 AM
To: Joshua Seidner
Subject: Re: Lost Sunglasses

Great news! Will someone be around at 12:30ish? I can walk down and pick them up.

On Wed, Feb 12, 2014 at 11:16 AM, Joshua Seidner <jseidner@trumporg.com> wrote:
I am wearing them now!! I guess I will give them back.

They are safe at OPO in room 207 with Kati, the office manager.....could you stop in to pick them up?

Thank you for the research regarding other hotel projects. I am looking forward to that list!

Best regards,
Josh



Joshua D. Seidner

Vice President, Design & Development
725 Fifth Avenue | New York, NY | 10022
p. 212.836.3231 | m. 908.963.4097
jseidner@trumporg.com | trump.com

From: Tepper, Audrey [mailto:audrey_tepper@nps.gov]
Sent: Wednesday, February 12, 2014 11:12 AM
To: David Orowitz; Joshua Seidner
Subject: Lost Sunglasses

Gents:

Did either of you happen to come across a pair of prescription sunglasses yesterday after our meeting? I may have accidentally set them down somewhere in your office. They're on the big side, brown plastic, dark lenses...

It was nice seeing you yesterday. Although we have quite a few things to work out, I remain convinced we'll come to agreements on these issues. It will require additional back and forth, but this is par for the course for tax credit projects.

Joshua, I asked my office at a staff meeting this morning for names of good hotel tax credit rehabs I can share with you. I have several names to pass along, but the only problem is that I have the historic names of the properties and I need to figure out what they're called today. I'll get them to you as shortly.

Thanks and please let me know about the sunglasses. Leave it to me to lose yet a-n-o-t-h-e-r pair!

--

Audrey T. Tepper - LEED Green Associate
Historical Architect
National Park Service
Technical Preservation Services Branch
1201 Eye Street, NW - Org. 2200
Washington, DC 20005
202-354-2027
202-371-1616 (FAX)
audrey_tepper@nps.gov

This e-mail message, and any attachments to it, are for the sole use of the intended recipients, and may contain confidential and privileged information. Any unauthorized review, use, disclosure or distribution of this email message or its attachments is prohibited. If you are not the intended recipient, please contact the sender by reply email and destroy all copies of the original message. Please note that any views or opinions presented in this email are solely those of the author and do not necessarily represent those of the company. Finally, while the company uses virus protection, the recipient should check this email and any attachments for the presence of viruses. The company accepts no liability for any damage caused by any virus transmitted by this email.

--

Audrey T. Tepper - LEED Green Associate
Historical Architect
National Park Service
Technical Preservation Services Branch
1201 Eye Street, NW - Org. 2200
Washington, DC 20005
202-354-2027
202-371-1616 (FAX)

audrey_tepper@nps.gov

Successful Hotel Tax Credit Projects.pdf

From: [Tepper, Audrey](#)
To: [Joshua Seidner](#)
Cc: [Andrew Lewis](#); [David Orowitz](#)
Subject: Successful Hotel Tax Credit Projects
Date: Wednesday, February 12, 2014 2:47:23 PM
Attachments: [29214dc.good hotel rehabs.old post office.docx](#)

Joshua:

As promised, I've attached a list of hotels in various US cities that received tax credits for their rehabilitations. They are a variety of building types, were built at various times and have different levels of accommodation (no. of stars), but you can see they all look like polished establishments post-rehab. I tried to find examples that didn't start out as hotels, rather were office or bank conversions for example.

My list is brief...I provided the name of the city, the building, some basic facts on the property if I knew them and a web link. Should you want to know more about a particular rehab. I can always speak with the individual reviewer for more details. I guarantee you they all had challenges. but made it through in the end...

Good luck with all the snow. My plane to Florida was already canceled for tomorrow evening. I'm not happy, but there's little I can do except look forward to some serious shoveling.

--

Audrey T. Tepper - LEED Green Associate
Historical Architect
National Park Service
Technical Preservation Services Branch
1201 Eye Street, NW - Org. 2200
Washington, DC 20005
202-354-2027
202-371-1616 (FAX)
audrey_tepper@nps.govShould

29214dc.good hotel rehabs.old post office.pdf

Good Hotel Rehabilitations that Received Historic Preservation Tax Credits

Compiled by Audrey Tepper, National Park Service, Technical Preservation Services Branch - February 12, 2014

Chicago:

- **Hotel Burnham,**
- A Kimpton hotel in the former "Reliance Building"
- <http://www.burnhamhotel.com/>
- In the photo gallery, note the historic glass wall with interior windows and transoms.

- **Mather Tower Hotel**
- 75 East Wacker Drive, Chicago, IL
- <http://www.chicagoriverhotel.com/>

- **Langham Hotel:**
- In a former IBM Building designed by Mies Van Der Rohe
- <http://chicago.langhamhotels.com/photos/langham-chicago-hotel.htm>

Los Angeles:

- **The Standard Hotel**
- <http://standardhotels.com/downtown-la>

Lynchburg, VA:

- **The Craddock-Terry Hotel**
- A boutique hotel in a former shoe factory. This is an industrial building and not the look you're after, but I still think they did a nice job. What is not shown in the images is the huge fiberglass red shoe that hangs on the side of the building. Heck, it was there historically (well, at least in the 1970s),
- <http://www.craddockterryhotel.com/>

Milwaukee:

- **Hilton Garden Inn – Milwaukee**
- In the former "Loyalty Building"
- Similar to OPO with a large, central cortile
- In the photo gallery, note historic varnished wood paneling.
- <http://www.hiltongardeninmilwaukeedowntown.com>

Minneapolis:

- **W Minneapolis – The Foshay**
- In the former Foshay Tower, which is shaped like an Egyptian obelisk and was the tallest skyscraper west of the Mississippi for some time (but no longer by a long shot).

- http://www.wminneapolishotel.com/?PS=LGEN_AA_DNAD_CGGL_TPRP
- **Westin – Minneapolis**
- In a former “F&M” bank building, with a 1941 banking hall and a large 1960s addition.
- http://www.starwoodhotels.com/westin/property/overview/index.html?propertyID=1723&PS=LGEN_AA_DNAD_CGGL_TPRP

Philadelphia:

- **Hotel Palomar**
- Art Deco
- <http://www.hotelpalomar-philadelphia.com>
- **Loews Philadelphia Hotel**
- In the former “PSF “ bank building
- <http://www.loewshotels.com/en/Philadelphia-Hotel>

Richmond, VA:

- **Hilton Garden Inn Downtown Richmond**
- In a former department store (Miller & Rhoads).
- <http://hiltongardeninn3.hilton.com/en/hotels/virginia/hilton-garden-inn-richmond-downtown-RICDTGI/index.html>

Salt Lake City:

- **Hotel Monaco**
- A Kimpton hotel In a former bank building
- <http://www.monaco-saltlakecity.com/>

Tulsa:

- **Atlas Hotel**
- In the former Atlas Life Insurance Building
- A Courtyard by Marriott
- <http://www.marriott.com/hotels/travel/tultd-courtyard-tulsa-downtown/>

RE_ Successful Hotel Tax Credit Projects.pdf

From: [Joshua Seidner](#)
To: [Tepper, Audrey](#)
Cc: [Andrew Lewis](#); [David Orowitz](#)
Subject: RE: Successful Hotel Tax Credit Projects
Date: Wednesday, February 12, 2014 4:31:04 PM
Attachments: [image001.png](#)

Hi Audrey,

This is extremely helpful. Thank you for putting this together. I am looking forward to reviewing this with the team.

Sorry about Florida....I guess you didn't need those sunglasses back, huh? (You did get them right?)

Best regards,

Josh



Joshua D. Seidner

Vice President, Design & Development
725 Fifth Avenue | New York, NY | 10022
p. 212.836.3231 | m. 908.963.4097
jseidner@trumporg.com | trump.com

From: Tepper, Audrey [mailto:audrey_tepper@nps.gov]
Sent: Wednesday, February 12, 2014 4:47 PM
To: Joshua Seidner
Cc: Andrew Lewis; David Orowitz
Subject: Successful Hotel Tax Credit Projects

Joshua:

As promised, I've attached a list of hotels in various US cities that received tax credits for their rehabilitations. They are a variety of building types, were built at various times and have different levels of accommodation (no. of stars), but you can see they all look like polished establishments post-rehab. I tried to find examples that didn't start out as hotels, rather were office or bank conversions for example.

My list is brief...I provided the name of the city, the building, some basic facts on the property if I knew them and a web link. Should you want to know more about a particular rehab. I can always speak with the individual reviewer for more details. I guarantee you they all had challenges. but made it through in the end...

Good luck with all the snow. My plane to Florida was already canceled for tomorrow evening. I'm not happy, but there's little I can do except look forward to some serious shoveling.

--

Audrey T. Tepper - LEED Green Associate
Historical Architect
National Park Service

Technical Preservation Services Branch
1201 Eye Street, NW - Org. 2200
Washington, DC 20005
202-354-2027
202-371-1616 (FAX)

audrey_tepper@nps.govShould

This e-mail message, and any attachments to it, are for the sole use of the intended recipients, and may contain confidential and privileged information. Any unauthorized review, use, disclosure or distribution of this email message or its attachments is prohibited. If you are not the intended recipient, please contact the sender by reply email and destroy all copies of the original message. Please note that any views or opinions presented in this email are solely those of the author and do not necessarily represent those of the company. Finally, while the company uses virus protection, the recipient should check this email and any attachments for the presence of viruses. The company accepts no liability for any damage caused by any virus transmitted by this email.

Re_ Successful Hotel Tax Credit Projects_1.pdf

From: [Tepper, Audrey](#)
To: [Joshua Seidner](#)
Subject: Re: Successful Hotel Tax Credit Projects
Date: Thursday, February 13, 2014 12:14:44 PM
Attachments: [image001.png](#)

Josh:

Yes, I forgot to thank you for setting my sunglasses aside for me...getting them back made my day. I needed them this morning when we walked to help a neighbor dig out from all this snow..it's bright out there! We got approx. 14" in Bethesda, MD where I live and more is expected. Along with all schools, the federal gov't was shut down today. In true Washington-snow-removal fashion (such wimps!), nothing on side streets is plowed, so if I wanted to get to work, it would be a real challenge. Luckily, I brought work home, so here I am.

Glad you found the hotel list helpful. What I neglected to stress in my note to you is that these rehabs all meet the Secretary of the Interior's Standards because the characters of the buildings - inside and out - remained intact post-construction. They were 'improved' appropriately using furnishings rather than permanent changes. This approach allowed the historic fabric of the interiors to read after-the-fact. It was not covered up behind new finishes, rather highlighted. I know the powers-that-be were not happy with our meeting, but we're just beginning the tax credit negotiation process, so I'm certainly not ready to give up yet. We'll get there with a bit more back and forth; something I'm quite used to with even the most complex projects...I've seen it all at this stage of my career,

I'm sure we'll be in touch and if you need further assistance, I'm here with my bevy of rehab examples.

Audrey

On Wed, Feb 12, 2014 at 6:32 PM, Joshua Seidner <jseidner@trumporg.com> wrote:

Hi Audrey,

This is extremely helpful. Thank you for putting this together. I am looking forward to reviewing this with the team.

Sorry about Florida....I guess you didn't need those sunglasses back, huh? (You did get them right?)

Best regards,

Josh

TRUMP

THE TRUMP ORGANIZATION

Joshua D. Seidner

Vice President, Design & Development
725 Fifth Avenue | New York, NY | 10022
p. 212.836.3231 | m. 908.963.4097

jseidner@trumporg.com | trump.com

From: Tepper, Audrey [mailto:audrey_tepper@nps.gov]
Sent: Wednesday, February 12, 2014 4:47 PM
To: Joshua Seidner
Cc: Andrew Lewis; David Orowitz
Subject: Successful Hotel Tax Credit Projects

Joshua:

As promised, I've attached a list of hotels in various US cities that received tax credits for their rehabilitations. They are a variety of building types, were built at various times and have different levels of accommodation (no. of stars), but you can see they all look like polished establishments post-rehab. I tried to find examples that didn't start out as hotels, rather were office or bank conversions for example.

My list is brief...I provided the name of the city, the building, some basic facts on the property if I knew them and a web link. Should you want to know more about a particular rehab. I can always speak with the individual reviewer for more details. I guarantee you they all had challenges. but made it through in the end...

Good luck with all the snow. My plane to Florida was already canceled for tomorrow evening. I'm not happy, but there's little I can do except look forward to some serious shoveling.

--

Audrey T. Tepper - LEED Green Associate

Historical Architect

National Park Service

Technical Preservation Services Branch

1201 Eye Street, NW - Org. 2200

Washington, DC 20005

202-354-2027

202-371-1616 (FAX)

audrey_tepper@nps.govShould

This e-mail message, and any attachments to it, are for the sole use of the intended recipients, and may contain confidential and privileged information. Any unauthorized review, use, disclosure or distribution of this email message or its attachments is prohibited. If you are not the intended recipient, please contact the sender by reply email and destroy all copies of the original message. Please note that any views or opinions presented in this email are solely those of the author and do not necessarily represent those of the company. Finally, while the company uses virus protection, the recipient should check this email and any attachments for the presence of viruses. The company accepts no liability for any damage caused by any virus transmitted by this email.

--

Audrey T. Tepper - LEED Green Associate
Historical Architect
National Park Service
Technical Preservation Services Branch
1201 Eye Street, NW - Org. 2200
Washington, DC 20005
202-354-2027
202-371-1616 (FAX)
audrey_tepper@nps.gov

RE_ OPO Design Meeting - Draft Notes for Review....pdf

From: [David Orowitz](#)
To: [Danielle Breaux - WPS-C](#); [Goeken Brian](#); [Audrey Tepper](#); [Andrew Lewis](#); [john_sandor@nps.gov](#); [David Maloney](#); [Tom Luebke](#); [Andrew Weiss](#); [Ivanka Trump](#); [Joshua Seidner](#); [Stephen Dalton](#); [Hany Hassan](#)
Cc: [Kevin Terry - WPRA](#); [Brett Banks](#); [Nancy Witherell - WPDA](#); [Mina Wright - WPD](#); [Edmund Newman - WPS](#)
Subject: RE: OPO Design Meeting - Draft Notes for Review/Comment
Date: Thursday, March 06, 2014 1:41:59 PM
Attachments: [OPO DesignMtg_02_26notes_DRAFT for review.docx](#)

All,

Please find my comments to the document with track changes. As an update to the group, we are pushing ahead quickly with the work that we agreed to do at the meeting last week. We will be in touch very soon to attempt to get final resolution on these items.

Best,
Dave

David Orowitz
Senior Vice President, Acquisitions and Development
The Trump Organization
725 Fifth Avenue | New York, NY | 10022
p. 212 836 3252 | m. 646 315.4698 | f. 212 836 3202
dorowitz@trumporg.com | trump.com

From: Danielle Breaux - WPS-C [<mailto:danielle.breaux@gsa.gov>]
Sent: Thursday, March 06, 2014 2:52 PM
To: Goeken, Brian; Audrey Tepper; Andrew Lewis; [john_sandor@nps.gov](#); David Maloney; Tom Luebke; David Orowitz; Andrew Weiss; Ivanka Trump; Joshua Seidner; Stephen Dalton; Hany Hassan
Cc: Kevin Terry - WPRA; Brett Banks; Nancy Witherell - WPDA; Mina Wright - WPD; Edmund Newman - WPS
Subject: Re: OPO Design Meeting - Draft Notes for Review/Comment

All -
For everyone's use and information, below are Audrey's comments to the notes.

----- Forwarded message -----
From: **Tepper, Audrey** <audrey_tepper@nps.gov>
Date: Thu, Mar 6, 2014 at 2:28 PM
Subject: Re: OPO Design Meeting - Draft Notes for Review/Comment
To: Danielle Breaux - WPS-C <danielle.breaux@gsa.gov>
Cc: Andrew Lewis <andrew.lewis@dc.gov>, Brian Goeken <brian_goeken@nps.gov>

Danielle:

Below are my comments on the most recent set of meeting minutes for the OPO meeting held on 2/28/14. Thanks for writing these up...

Audrey

1. Guestroom Entranceway, B., Door Replacement - Resolution - ii
"Design replacement doors with new glass inserts in lieu of wood panel inserts if uniformity is desired."

This needs to be corrected, as one of the things NPS (and the Sec. Standards) stress is the retention of as much historic fabric as possible. If original cortile corridor doors will no longer function, they may be repaired/refinished (with original glass panels extant); fixed in place, have their hardware removed, and potentially be covered with shear fabric. Unless they are damaged beyond repair, they should not be removed and replaced with new doors, even if the new doors match.

2. Window Walls, B., Double-Hung Window Sash Replacement, Resolution
I believe we recommended a three-tiered approach to the window survey criteria based on individual window conditions:
1) Full repair and retention if window is in good condition;
2) Replacement of upper or lower sash only depending on condition;
3) Full replacement of window if condition is exceptionally poor.

Of course isolated repair of surrounding window frames, sills/stools and glass will be required.

It also be noted that NPS requested a full examination of exterior window conditions, as well as interior conditions, as there may be significant deterioration outside allowing moisture to both damage window assemblies and migrate inside.

3. General, C. Interior Stair Handrails at the Stairwells Surround the Elevators
"If historic fabric is impacted. NPS and DCSHPO will review." Please remove statement, as we review any and all permanent changes to the building.

"NPS confirmed....is acceptable for tax credit." Typo...should be "tax credits."

4. General, E. Mezzanine Grill Proposal.

I am confused by the term "grill" in the above heading. Doesn't this refer to the new railing at the mezzanine, both the safety railing and the railing at the stairs? At first I thought you were talking about the inserted "screens" at the 11 Street lobby.

5. General, G. Window Screen Proposal at 11th Street Lobby, Resolution, i
"Review the historic photos to provide an alternative design for the screen that does not damage the historic fabric." I believe the point here was that there is no historic precedent for a decorative screen in this location and that its installation is historically inappropriate, not that its installation will destroy historic fabric.

6. There was also discussion of how the cortile would be vented. Trump said that smoke evacuation is through existing louvers in the courtyard with fans on the roof. We should be informed if this approach changes.

Hope this helps!

Audrey

Danielle Breaux

Project Manager - Contractor
U.S. General Services Administration
Office of Planning & Design Quality
Tel 202.288.1298
Em danielle.breaux@gsa.gov

On Wed, Mar 5, 2014 at 1:59 PM, Danielle Breaux - WPS-C <danielle.breaux@gsa.gov> wrote:

All -

Attached for your review/comment are draft notes from the Feb 26th OPO Design Meeting. We have focused these notes on the design direction and/or resolution on items discussed at the meeting. **Please cc all on this email with any comments/edits to these notes at your earliest convenience.**

Upon receipt of any additional comments/edits, GSA will compile a revised version.

Thank you all once again for your time last week,
Danielle

Danielle Breaux

Project Manager - Contractor
U.S. General Services Administration
Office of Planning & Design Quality
Tel [202.288.1298](tel:202.288.1298)
Em danielle.breaux@gsa.gov

This e-mail message, and any attachments to it, are for the sole use of the intended recipients, and may contain confidential and privileged information. Any unauthorized review, use, disclosure or distribution of this email message or its attachments is prohibited. If you are not the intended recipient, please contact the sender by reply email and destroy all copies of the original message. Please note that any views or opinions presented in this email are solely those of the author and do not necessarily represent those of the company. Finally, while the company uses virus protection, the recipient should check this email and any attachments for the presence of viruses. The company accepts no liability for any damage caused by any virus transmitted by this email.

OPO DesignMtg_02 26notes_DRAFT for review.pdf

OPO Design Meeting

February 26, 2014

General Note: At the opening of the meeting, NPS stated that meeting notes to document the discussion are a helpful tool but noted that nothing is binding until the NPS receives and reviews the Part 2 application.

GSA compiled these notes to represent the design direction and/or resolution on specific design items discussed in the meeting for review and comment. GSA has no role in the tax credit process and is acting strictly in its Section 106 and 110 capacities.

1. Guestroom Entranceway

A. Room Layout

Resolution: The Trump team noted that the diffuser may need a minimal amount of additional space and that the diffuser was not the driving force in the decision to set-back door (fire wall requires this). NPS encouraged the Trump team to study the treatment of the glass (back painted or other) as the HVAC equipment may be visible through the glass. Trump confirmed that no return air will be installed in the corridors.

B. Door Replacement

The revised proposal included replacement of all doors on the guest room floors, with the exception of the doors that will remain in a hold open position (primarily at the corner suites). NPS and DCSHPO responded that they are agreeable with a replacement Oak door inclusive of a solid panel on the guest room doors only to accommodate code. They added that the historic doors (with glass panels) should remain in place for the fixed doors and could be refinished if needed.

The Trump team wants to maintain aesthetic consistency with both the fixed and replacement doors along the corridors. As such, they suggested an alternative approach to replace the glass panels with solid wood panels within the existing doors to be fixed. NPS is not able to accept an alternative that would alter existing historic fabric when no alteration is necessary.

Resolution: No resolution on this item. Trump was asked to consider the following and complete a mock-up of the sheer fabric option below if this is the proposal Trump intends to pursue.

- i. Use historic doors for the fixed doors and the replacement doors for the guest rooms.
- ii. Design replacement doors with new glass panels in lieu of wood panel inserts if uniformity is desired.
- iii. Pull the sheer fabric across the fixed historic doors to allow for the entire historic window/door unit to be perceived through the sheer.

OPO Design Meeting

February 26, 2014

C. Drapery

The revised proposal incorporated a series of fixed independently hung draperies and sheers in front of each guestroom entranceway. The sheers would be hung in front of the window/wall area to allow for the window unit to be perceived through the sheers. A roman shade made of the sheer material would be hung in front of the transom above the door.

Resolution: NPS and DCSHPO could conceptually go along with the revised entranceway concept provided that the sheer across the windows and the roman shade in front of the transom allows one to perceive the elements that make up the window unit through the sheers. NPS and DCSHPO requested a mock-up of this concept to better understand the translucency of the sheers and ability to perceive the window unit.

D. Hallway Sconces and Carpet Runners

Resolution: No new comments; proposals shown on Feb 21st are acceptable

2. Window Walls

A. Replacement of all Exterior Wall Base Molding

Agreement that all baseboards along the exterior wall are to be replaced in kind.

Discussion occurred on whether or not to make all baseboard of the same profile or differentiate between existing (along exterior wall) and new baseboard (interior walls).

Resolution: No resolution at this time. Trump will revisit the topic and come back to the group with a proposed solution.

B. Double Hung Window Sash Replacement

Resolution: Trump will conduct a window survey inclusive of the sills, stools and wainscoting. Trump will establish both an interior and exterior standard for various levels of replacement when repair cannot be achieved and will document representative samples as deemed appropriate. Trump will review the standards for replacement with NPS and DCSHPO prior to conducting the survey. Trump agreed that all replacement would be done in-kind. The existing glass panes will be retained and reused in replacement sashes.

C. Fur out for Chases

Resolution: In order to minimize the fur out encroachment into the window opening, Trump will use a 7/8" fur out channel on the window side to keep the fur out to an absolute minimum and any additional fur out will occur on the wall facing into the room. Trump will use a rounded corner bead to match the historic corner beads in the building.

3. General

OPO Design Meeting

February 26, 2014

A. Clear Glass Replacement at 3rd and 8th Floors

Resolution: No new comments; proposals discussed on Feb 21st are acceptable

B. Utilizing glass doors at Retail

Resolution: Trump will submit a concept for the doors and will provide existing photos and plans to clearly depict the area to SHPO and NPS in the Part 2. Trump understands that an amendment for the design of the space will need to be submitted to SHPO and NPS at a later date once a Tenant is identified and the space is designed.

C. Interior Stair Handrails at the Stairwells surrounding the elevators

Resolution: Proposals will need to be submitted in Part 2 ~~if modifications are proposed to~~ meet this code condition. GSA and Trump to discuss further. Design solutions should be simple. If historic fabric is impacted, NPS and DCSHPO will review. NPS confirmed that the addition of an appropriate railing at this location is acceptable for tax credit.

D. Cortile Guardrails

Resolution: Proposals will need to be submitted in Part 2 if modifications are proposed to meet this code condition. GSA and Trump to discuss further. Design solutions should be simple. If historic fabric is impacted, NPS and DCSHPO will review. NPS confirmed that the addition of an appropriate barrier at this location is acceptable for tax credit.

~~E. Mezzanine Grill Proposal~~

~~Resolution: No new comments; proposal utilizing a finish of black wrought iron with brass details and design shown on Feb 24st is acceptable~~

~~F.E. Mezzanine/Monumental Stair Railing Proposal~~

~~Resolution: No new comments; proposal utilizing a finish of black wrought iron with brass details and design shown on Feb 21st is acceptable~~

~~G.F. Window Screen Proposal at 11th Street Lobby~~

~~Resolution: No resolution on this item. Trump was asked to look at historic photos of the original condition, consider the following options, and come back to the group with a proposal.~~

- ~~i. Review the historic photos to provide an alternative design for the screen that does not damage the historic fabric.~~
- ~~ii. Design a 'furniture' freestanding screen that is behind the openings and not within the window casing, which – as furniture – could be more ornate than an attached screen.~~

~~H.G. Exterior Handrails at 11th and 12th Streets and Pennsylvania Avenue~~

~~Resolution: Trump was asked to provide a 'simplified design' for the handrail. GSA is pursuing a waiver for the additional handrails.~~

OPO Design Meeting

February 26, 2014

H. Request for no reopening of S106 – There should be no need to reopen Section 106 if the application for Historic Tax Credits is successfully completed.

I. NPS Acknowledgement with regard to furniture and furnishing choices – NPS is unable to make any such acknowledgement without a Part 2 being submitted.

J. Lighting Fixtures

Resolution: Lighting fixtures on the 2nd through 8th floor are acceptable as proposed.

K. Corridor Carpets

Resolution: Corridor carpets will be runners and end at the edge of the black tile without revealing the white tiles.

L. Gold Leaf on the Elevator Cages

Resolution: Acceptable as proposed on the February 21st walk through.

J.M.

Formatted: Font: Bold

Formatted: Line spacing: Multiple 1.15 li

Formatted: Font: Bold

Formatted: Indent: Left: 0.5", Line spacing: Multiple 1.15 li, No bullets or numbering

Formatted: Underline

Formatted: Superscript

Formatted: Superscript

Formatted: Normal, Indent: Left: 0.25", No bullets or numbering

Formatted: Superscript

Formatted: Font: Bold

Formatted: Indent: Left: 0.5", Line spacing: Multiple 1.15 li, No bullets or numbering

Re_ Follow up to our meeting.pdf

From: [Sandor, John](#)
To: [Hany Hassan](#)
Cc: [Audrey Tepper](#); [Andrew \(OP\) Lewis](#); [David Orowitz](#); [Nancy Witherell](#); [danielle Breaux](#)
Subject: Re: Follow up to our meeting
Date: Thursday, March 06, 2014 5:57:47 PM

Aside from Wednesday morning, I have flexibility for next week.

John Sandor
Technical Preservation Services
202-354-2030

On Thu, Mar 6, 2014 at 7:04 PM, Hany Hassan <hhassan@bbbarch.com> wrote:
Audrey, Andrew and John:

Per our discussion during last meeting, please let me know your availability the latter part of next week.

Best regards,

Hany

Hany Hassan FAIA
Partner

Beyer Blinder Belle
Architects & Planners LLP
3307 M Street, NW, Suite 301
Washington, DC 20007
[202-333-8000](tel:202-333-8000)
[202 333 8843](tel:202-333-8843) fax
hhassan@bbbarch.com
www.beyerblinderbelle.com

The above e-mail is for the intended recipient only, and may contain information that is privileged, confidential, or otherwise protected from disclosure. If you are not the intended recipient, please advise the sender immediately. Nothing in this e-mail or any attachments to this e-mail grants any license or transfers any ownership to the contents of the e-mail or attachments or any intellectual property rights contained therein. Unauthorized use or distribution is prohibited and may be unlawful. Beyer Blinder Belle Architects Planners LLP accepts no responsibility for any loss or damage from the use of this message and/or any attachments including damage from viruses.

Re_ Follow up to our meeting(1).pdf

From: [Tepper, Audrey](#)
To: [Hany Hassan](#)
Cc: [Sandor, John](#); [Andrew \(OP\) Lewis](#); [David Orowitz](#); [Nancy Witherell](#); [danielle Breaux](#)
Subject: Re: Follow up to our meeting
Date: Friday, March 07, 2014 7:51:32 AM

3/13 is the only day that does work for me ...morning if possible.

Thanks,

Audrey.

On Fri, Mar 7, 2014 at 9:30 AM, Hany Hassan <hhassan@bbbarch.com> wrote:
Would Thursday March 13 work with your schedule(s)?

Hany Hassan FAIA
Partner

Beyer Blinder Belle
Architects & Planners LLP
3307 M Street, NW, Suite 301
Washington, DC 20007
[202-333-8000](tel:202-333-8000)
[202 333 8843](tel:202-333-8843) fax
hhassan@bbbarch.com
www.beyerblinderbelle.com

The above e-mail is for the intended recipient only, and may contain information that is privileged, confidential, or otherwise protected from disclosure. If you are not the intended recipient, please advise the sender immediately. Nothing in this e-mail or any attachments to this e-mail grants any license or transfers any ownership to the contents of the e-mail or attachments or any intellectual property rights contained therein. Unauthorized use or distribution is prohibited and may be unlawful. Beyer Blinder Belle Architects Planners LLP accepts no responsibility for any loss or damage from the use of this message and/or any attachments including damage from viruses.

On Mar 6, 2014, at 7:57 PM, "Sandor, John" <john_sandor@nps.gov> wrote:

Aside from Wednesday morning, I have flexibility for next week.

John Sandor
Technical Preservation Services
202-354-2030

On Thu, Mar 6, 2014 at 7:04 PM, Hany Hassan <hhassan@bbbarch.com> wrote:

Audrey, Andrew and John:

Per our discussion during last meeting, please let me know your availability the latter part of next week.

Best regards,

Hany

Hany Hassan FAIA
Partner

Beyer Blinder Belle
Architects & Planners LLP
3307 M Street, NW, Suite 301
Washington, DC 20007
[202-333-8000](tel:202-333-8000)
[202 333 8843](tel:202-333-8843) fax
hhassan@bbbarch.com
www.beyerblinderbelle.com

The above e-mail is for the intended recipient only, and may contain information that is privileged, confidential, or otherwise protected from disclosure. If you are not the intended recipient, please advise the sender immediately. Nothing in this e-mail or any attachments to this e-mail grants any license or transfers any ownership to the contents of the e-mail or attachments or any intellectual property rights contained therein. Unauthorized use or distribution is prohibited and may be unlawful. Beyer Blinder Belle Architects Planners LLP accepts no responsibility for any loss or damage from the use of this message and/or any attachments including damage from viruses.

--

Audrey T. Tepper - LEED Green Associate
Historical Architect
National Park Service
Technical Preservation Services Branch
1201 Eye Street, NW - Org. 2200
Washington, DC 20005
202-354-2027
202-371-1616 (FAX)
audrey_tepper@nps.gov

Old Post Office(1).pdf

From: [Stephen Dalton](#)
To: john_sandor@nps.gov
Subject: Old Post Office
Date: Tuesday, April 22, 2014 12:05:18 PM

This did not get through for some reason when I sent it, so I am resending here. I also left you a voice mail. Thanks.

Further to my other e-mails about disassembling one wainscot and stool at the South side of the 3rd Floor (SW) and the subsequent approval by GSA to do this scope of work, we will be doing this work tomorrow. We will be photographing and documenting the material before during and after removal and then storing it on site. This is being done so we can better understand the scope of work necessary for treating this historic material. I am copying Audrey Tepper and John Sandor of NPS directly as I know that Mr. Sandor was interested in seeing this when he was here on a visit. Let me know if you have any questions.

Stephen H. Dalton, AIA
The Trump Old Post Office LLC
1100 Pennsylvania Avenue, NW
Room 207
Washington, DC 20007
Tel 202-309-3945
Fax 202-318-0067

This e-mail message, and any attachments to it, are for the sole use of the intended recipients, and may contain confidential and privileged information. Any unauthorized review, use, disclosure or distribution of this email message or its attachments is prohibited. If you are not the intended recipient, please contact the sender by reply email and destroy all copies of the original message. Please note that any views or opinions presented in this email are solely those of the author and do not necessarily represent those of the company. Finally, while the company uses virus protection, the recipient should check this email and any attachments for the presence of viruses. The company accepts no liability for any damage caused by any virus transmitted by this email.

Re_ Old Post Office NPS Permit Application.pdf

From: [Gowen, Jeffrey](#)
To: [Danielle Breaux - WPS-C](#)
Cc: [Sean Kennealy](#); [James Perry](#); [Brett Banks](#); [Edmund Newman - WPS](#); [Steve Dalton](#); [Andrew Weiss](#); [David Orowitz](#); [Kevin Terry - WPRA](#)
Subject: Re: Old Post Office NPS Permit Application
Date: Wednesday, May 07, 2014 1:39:55 PM

Danielle,

The permit application had two different checks. It seems like it would be easier to roll all of the work into one permit as the POCs are the same for both applications. Is there a particular reason you would like two permits? I can return one of the application checks to you. After reviewing the drawings and permit application the bond amount will be set at \$20,000. The bond can come from an authorized bonding company or in the form of cash or cash equivalent, to guarantee that all financial obligations to the park will be met, including the restoration and rehabilitation of the permitted area.

Please let me know how you want to handle the extra check.

Thanks,

Jeff

On Wed, Apr 30, 2014 at 11:03 AM, Danielle Breaux - WPS-C <danielle.breaux@gsa.gov> wrote:

Jeff -

This afternoon we will deliver a hard copy of the NPS Permit Application Materials for the Old Post Office Redevelopment Project to your attention at the Permit/Professional Services Building front desk at 900 Ohio Drive. Included in this email are the electronic versions of those materials as well. We understand there may need to be a bond posted for the Short Term Construction Permit but we were not sure how that is calculated so please let us know what is needed for that once you receive the permit application. Please do not hesitate to contact us with any questions or if another site visit, meeting or additional information is required as part of your permit review.

A. Special Use Permit for the temporary covered walkway with parapet on Pennsylvania Avenue and part of 12th Street, NW that is required to protect the public from the construction activities for the renovation of the Old Post Office project. This package will include:

1. Special Use Permit (SUP) application with GSA as applicant.
2. Permit Application fee of \$250 (check included in hard copy package)
3. Drawing: C-3.1 Enlarged Site Plan
4. Drawing: SK012314 Parapet Area Plan, Elevation and Section
5. Rendering of temporary covered walkway with parapet
6. Drawing: Preliminary Site Logistics Plan

B. Short Term Construction Permit for the new curb cut installation.

This package will include:

1. Short Term Construction Permit (STCP) application with GSA as applicant.
2. Permit Application fee of \$250 (check included in hard copy package)
3. Drawing: C-3.1 Enlarged Site Plan
4. Drawing: C-7 Erosion and Sediment Control Plan
5. Drawing: C-11 Traffic Control Plan
6. Photographs of area to be disturbed
7. Certificates of Liability Insurance (Trump and Lend Lease)
8. Bond: As noted above, please advise on the bond amount if it is necessary.

Thank you in advance for your continued assistance with this project,
Danielle

Danielle Breaux

Project Manager - Contractor
U.S. General Services Administration
Office of Planning & Design Quality
Tel 202.288.1298
Em danielle.breaux@gsa.gov

--

Jeff Gowen
Landscape Architect
National Mall and Memorial Parks
202-841-0110

Re_ Old Post Office NPS Permit Application(1).pdf

From: [Gowen, Jeffrey](#)
To: [Danielle Breaux - WPS-C](#)
Cc: [Sean Kennealy](#); [James Perry](#); [Brett Banks](#); [Edmund Newman - WPS](#); [Steve Dalton](#); [Andrew Weiss](#); [David Orowitz](#); [Kevin Terry - WPRA](#); [Ned Wallace](#)
Subject: Re: Old Post Office NPS Permit Application
Date: Thursday, May 08, 2014 6:15:43 AM
Attachments: [Parapet Area Plan with NPS comments.pdf](#)

Danielle,

Once I have the bond and the NPS team has reviewed and approved the drawings, it should only take a day or two to send GSA a copy of the permit to sign. The bond is basically a performance bond, with GSA or Trump designated as the contractor, NPS as the owner and the bonding company as the surety. A standard AIA performance bond is typical.

I have attached a copy of the parapet area plan with comments. The parapet is in conflict with the existing trees. What is the purpose of the parapet? and what is the plan for dealing with the areas where the parapet is in conflict with the existing trees? Please note that commercial advertising will not be allowed to be hung on the outside of the parapet on NPS property.

Thanks,

Jeff

On Wed, May 7, 2014 at 4:14 PM, Danielle Breaux - WPS-C <danielle.breaux@gsa.gov> wrote:

Jeff -

Thank you for the prompt reply. We are fine with doing this under one permit but would want the permit time frame to the longer time frame noted in the special use permit (through July 2016). You can return one of the checks to the GSA POC or we can have someone pick it up from your office - just let us know what is best for you. Trump is working on the bond now and I hope to have a better update on the status of it later this week. Once we get the bond in place, is there anything else you need from us? And if not, what would be the timeframe to get the permit?

Thank you in advance for your help with this,
Danielle

Danielle Breaux

Project Manager - Contractor
U.S. General Services Administration
Office of Planning & Design Quality
Tel 202.288.1298
Em danielle.breaux@gsa.gov

On Wed, May 7, 2014 at 3:39 PM, Gowen, Jeffrey <jeff_gowen@nps.gov> wrote:
Danielle,

The permit application had two different checks. It seems like it would be easier to roll all of the work into one permit as the POCs are the same for both applications. Is there a particular reason you would like two permits? I can return one of the application checks to you. After reviewing the drawings and permit application the bond amount will be set at \$20,000. The bond can come from an authorized bonding company or in the form of cash or cash equivalent, to guarantee that all financial obligations to the park will be met, including the restoration and rehabilitation of the permitted area.

Please let me know how you want to handle the extra check.

Thanks,

Jeff

On Wed, Apr 30, 2014 at 11:03 AM, Danielle Breaux - WPS-C

<danielle.breaux@gsa.gov> wrote:

Jeff -

This afternoon we will deliver a hard copy of the NPS Permit Application Materials for the Old Post Office Redevelopment Project to your attention at the Permit/Professional Services Building front desk at 900 Ohio Drive. Included in this email are the electronic versions of those materials as well. We understand there may need to be a bond posted for the Short Term Construction Permit but we were not sure how that is calculated so please let us know what is needed for that once you receive the permit application. Please do not hesitate to contact us with any questions or if another site visit, meeting or additional information is required as part of your permit review.

A. Special Use Permit for the temporary covered walkway with parapet on Pennsylvania Avenue and part of 12th Street, NW that is required to protect the public from the construction activities for the renovation of the Old Post Office project. This package will include:

1. Special Use Permit (SUP) application with GSA as applicant.
2. Permit Application fee of \$250 (check included in hard copy package)
3. Drawing: C-3.1 Enlarged Site Plan
4. Drawing: SK012314 Parapet Area Plan, Elevation and Section
5. Rendering of temporary covered walkway with parapet
6. Drawing: Preliminary Site Logistics Plan

B. Short Term Construction Permit for the new curb cut installation.

This package will include:

1. Short Term Construction Permit (STCP) application with GSA as applicant.
2. Permit Application fee of \$250 (check included in hard copy package)
3. Drawing: C-3.1 Enlarged Site Plan
4. Drawing: C-7 Erosion and Sediment Control Plan
5. Drawing: C-11 Traffic Control Plan
6. Photographs of area to be disturbed
7. Certificates of Liability Insurance (Trump and Lend Lease)
8. Bond: As noted above, please advise on the bond amount if it is necessary.

Thank you in advance for your continued assistance with this project,
Danielle

Danielle Breaux

Project Manager - Contractor
U.S. General Services Administration
Office of Planning & Design Quality
Tel [202.288.1298](tel:202.288.1298)
Em danielle.breaux@gsa.gov

--

Jeff Gowen
Landscape Architect
National Mall and Memorial Parks
[202-841-0110](tel:202-841-0110)

--

Jeff Gowen
Landscape Architect
National Mall and Memorial Parks
202-841-0110

Parapet Area Plan with NPS comments.pdf

Meeting to Discuss NPS Space and Museum.pdf

From: [David Orowitz](#)
To: [Carolyn Richard](#); [Nixon, Robin](#)
Cc: ["Danielle Breaux"](#); [Kevin Terry - WPRA](#); [Brett Banks - WPT-C](#); edmund.newman@gsa.gov; [Andrew Weiss](#); [Stephen Dalton](#)
Subject: Meeting to Discuss NPS Space and Museum
Date: Tuesday, May 13, 2014 7:43:18 AM

Carolyn and Robin,

Hope all is well. I wanted to see if we could get a meeting in the calendar for June 10th (ideally afternoon) or 12th (ideally morning). The agenda would be as follows:

- 1) Review the updates to the plans for the build-out of NPS space
- 2) Discuss the overall concept and themes for the museum with our consultant (Char Lyons) and the division of content between the areas that will be fit-out by Trump and by NPS

I think that we should probably schedule 90 minutes (with some flexibility to go over a bit) to give us time to do brainstorming and make sure that we cover everything. Please let me know if there are some times that could work for you and your team.

Best,
Dave

David Orowitz
Senior Vice President, Acquisitions and Development
The Trump Organization
725 Fifth Avenue | New York, NY | 10022
p. 212.836.3252 | m. 646.315.4698 | f. 212.836.3202
dorowitz@trumporg.com | trump.com

This e-mail message, and any attachments to it, are for the sole use of the intended recipients, and may contain confidential and privileged information. Any unauthorized review, use, disclosure or distribution of this email message or its attachments is prohibited. If you are not the intended recipient, please contact the sender by reply email and destroy all copies of the original message. Please note that any views or opinions presented in this email are solely those of the author and do not necessarily represent those of the company. Finally, while the company uses virus protection, the recipient should check this email and any attachments for the presence of viruses. The company accepts no liability for any damage caused by any virus transmitted by this email.

Re_ Meeting to Discuss NPS Space and Museum.pdf

From: [Robin Nixon](#)
To: [David Orowitz](#)
Cc: [Carolyn Richard](#); [Danielle Breaux](#); [Kevin Terry - WPRA](#); [Brett Banks - WPT-C](#); edmund.newman@gsa.gov; [Andrew Weiss](#); [Stephen Dalton](#)
Subject: Re: Meeting to Discuss NPS Space and Museum
Date: Tuesday, May 13, 2014 8:21:48 AM

Will get back to you ASAP; I'm sure we can get one of those dates to work.

Sent from my iPad

On May 13, 2014, at 9:43 AM, David Orowitz <dorowitz@trumporg.com> wrote:

Carolyn and Robin,

Hope all is well. I wanted to see if we could get a meeting in the calendar for June 10th (ideally afternoon) or 12th (ideally morning). The agenda would be as follows:

- 1) Review the updates to the plans for the build-out of NPS space
- 2) Discuss the overall concept and themes for the museum with our consultant (Char Lyons) and the division of content between the areas that will be fit-out by Trump and by NPS

I think that we should probably schedule 90 minutes (with some flexibility to go over a bit) to give us time to do brainstorming and make sure that we cover everything. Please let me know if there are some times that could work for you and your team.

Best,
Dave

David Orowitz
Senior Vice President, Acquisitions and Development
The Trump Organization
725 Fifth Avenue | New York, NY | 10022
p. 212.836.3252 | m. 646.315.4698 | f. 212.836.3202
dorowitz@trumporg.com | trump.com

This e-mail message, and any attachments to it, are for the sole use of the intended recipients, and may contain confidential and privileged information. Any unauthorized review, use, disclosure or distribution of this email message or its attachments is prohibited. If you are not the intended recipient, please contact the sender by reply email and destroy all copies of the original message. Please note that any views or opinions presented in this email are solely those of the author and do not necessarily represent those of the company. Finally, while the company uses virus protection, the recipient should check this email and any attachments for the presence of viruses. The company accepts no liability for any damage caused by any virus transmitted by this email.

RE_Bonding.pdf

From: [Kati Bramhall](#)
To: [Regina Degnan](#); [Thomas Rhatigan](#); [Stephen Dalton](#); [David Orowitz](#)
Cc: [Ron Lieberman](#); [Andrew Weiss](#); [Dawn Cheah](#); gowen@nps.gov
Subject: RE: Bonding
Date: Wednesday, May 14, 2014 10:13:23 AM

Hello Everyone.

I have the bond and have prepared it for delivery and will be delivering it now. I am trying to reach Mr. Gowen in order to receive the items he is supposed to give to me when I deliver the bond but have been unable to reach him as of yet. Perhaps he has left them for me there at the permit office front desk. I will of course have them sign for the bond on the transmittals I am bringing with me.

Kati Bramhall
TRUMP OPO Office Manager
202.216.9039 office
310.488.0354 mobile
Trump Old Post Office, LLC
The Old Post Office Pavilion Building
1100 Pennsylvania Avenue
Suite 207, Northwest
Washington, DC 20004

-----Original Message-----

From: Regina Degnan [<mailto:regina.degnan@aon.com>]
Sent: Wednesday, May 14, 2014 10:32 AM
To: Thomas Rhatigan; Stephen Dalton; David Orowitz
Cc: Ron Lieberman; Andrew Weiss; Dawn Cheah; Kati Bramhall
Subject: RE: Bonding

Tom,

Terrific....thank you

Regina

-----Original Message-----

From: Thomas Rhatigan
Sent: Wednesday, May 14, 2014 10:30 AM
To: Stephen Dalton; Regina Degnan; David Orowitz
Cc: Ron Lieberman; Andrew Weiss; Dawn Cheah; Kati Bramhall
Subject: RE: Bonding

Tracking # is 798848454820

Delivered at 10:03am

Signed for by: K.BRAMHALL

Thomas Rhatigan
Aon Construction Services Group
199 Water Street
New York, NY 10038
(212) 441-2493 direct dial
(732) 890-3905 cell

(847) 953-0877 fax

-----Original Message-----

From: Stephen Dalton [<mailto:sdalton@trumporg.com>]

Sent: Tuesday, May 13, 2014 10:29 PM

To: Thomas Rhatigan; Regina Degnan; David Orowitz

Cc: Ron Lieberman; Andrew Weiss; Dawn Cheah; Kati Bramhall

Subject: Re: Bonding

No problem. Thanks.

Stephen H. Dalton, AIA

The Trump Old Post Office LLC

1100 Pennsylvania Avenue, NW Room 207

Washington, DC 20004

Tel 202-309-3945

Fax 202-318-0067

On 5/13/14, 10:27 PM, "Thomas Rhatigan" <thomas.rhatigan@aon.com> wrote:

>Yes, I'll have to get it in the morning.

>

>Tom

>

>----- Original Message -----

>From: Stephen Dalton [<mailto:sdalton@trumporg.com>]

>Sent: Tuesday, May 13, 2014 10:16 PM

>To: Thomas Rhatigan; Regina Degnan; David Orowitz

><dorowitz@trumporg.com>

>Cc: Ron Lieberman <rlieberman@trumporg.com>; Andrew Weiss

><aweiss@trumporg.com>; Dawn Cheah; Kati Bramhall

><kbramhall@trumporg.com>

>Subject: Re: Bonding

>

>Can I get a tracking number so we can look for it? Thanks.

>

>

>Stephen H. Dalton, AIA

>The Trump Old Post Office LLC

>1100 Pennsylvania Avenue, NW Room 207

>Washington, DC 20004

>Tel 202-309-3945

>Fax 202-318-0067

>

>

>

>

>On 5/13/14, 5:26 PM, "Thomas Rhatigan" <thomas.rhatigan@aon.com> wrote:

>

>>OK, I am having it sent as you request.

>>

>>Thanks

>>

>>Thomas Rhatigan

>>Aon Construction Services Group
>>199 Water Street
>>New York, NY 10038
>>(212) 441-2493 direct dial
>>(732) 890-3905 cell
>>(847) 953-0877 fax

>>
>>-----Original Message-----
>>From: Regina Degnan
>>Sent: Tuesday, May 13, 2014 5:02 PM
>>To: Thomas Rhatigan; 'dorowitz@trumporg.com'
>>Cc: 'rlieberman@trumporg.com'; 'sdalton@trumporg.com';
>>'aweiss@trumporg.com'; Dawn Cheah
>>Subject: Re: Bonding

>>
>>Tom

>>
>>We need the bond first thing tomorrow morning.

>>
>>Tom, we will send it directly to Steve Dalton via Fed Express return
>>receipt at ; Trump Old Post Office LLC, 1100 Pennsylvania Ave NW- RM
>>207, Washington, DC 20004,

>>
>>Thanks

>>
>>Regina

>>
>>----- Original Message -----
>>From: Thomas Rhatigan
>>Sent: Tuesday, May 13, 2014 04:09 PM
>>To: David Orowitz <dorowitz@trumporg.com>; Regina Degnan
>>Cc: Ron Lieberman <rlieberman@trumporg.com>; Stephen Dalton
>><sdalton@trumporg.com>; Andrew Weiss <aweiss@trumporg.com>
>>Subject: RE: Bonding

>>
>>David,
>>
>>The Bond is being prepared today and will be sent to you for delivery
>>tomorrow in NYC.

>>
>>Thomas Rhatigan
>>Aon Construction Services Group
>>199 Water Street
>>New York, NY 10038
>>(212) 441-2493 direct dial
>>(732) 890-3905 cell
>>(847) 953-0877 fax

>>
>>-----Original Message-----
>>From: David Orowitz [<mailto:dorowitz@trumporg.com>]
>>Sent: Tuesday, May 13, 2014 3:59 PM
>>To: Regina Degnan
>>Cc: Ron Lieberman; Stephen Dalton; Andrew Weiss; Thomas Rhatigan
>>Subject: RE: Bonding

>>
>>Tom,

>>

>>Any update on this? We were just contacted by GSA.

>>

>>Dave

>>

>>David Orowitz

>>Senior Vice President, Acquisitions and Development The Trump

>>Organization

>>725 Fifth Avenue | New York, NY | 10022 p. 212.836.3252 | m.

>>646.315.4698 | f. 212.836.3202 dorowitz@trumporg.com

>>| trump.com

>>

>>-----Original Message-----

>>From: Regina Degnan [<mailto:regina.degnan@aon.com>]

>>Sent: Monday, May 12, 2014 6:18 PM

>>To: David Orowitz

>>Cc: Ron Lieberman; Stephen Dalton; Andrew Weiss; Thomas Rhatigan

>>Subject: RE: Bonding

>>

>>David,

>>

>>Thank you. I have copied Tom Rhatigan who is our bond specialist.

>>Tom I will forward the bond application on to you. Please review and

>>let us know if anything else is needed , otherwise please proceed to

>>place this bond.

>>

>>This is critical for The Trump Organization to move forward with Trump

>>OPO.

>>

>>Thanks,

>>

>>Regina

>>

>>-----Original Message-----

>>From: David Orowitz [<mailto:dorowitz@trumporg.com>]

>>Sent: Monday, May 12, 2014 6:12 PM

>>To: Regina Degnan

>>Cc: Ron Lieberman; Stephen Dalton; Andrew Weiss

>>Subject: Bonding

>>Importance: High

>>

>>Regina,

>>

>>Please see attached how Andy, Steve and I think the bond application

>>should be completed. Is this what you need? If so, we need this bond

>>in place ASAP as we may need this permit to get our Notice to Proceed.

>>

>>Thanks,

>>Dave

>>

>>David Orowitz

>>Senior Vice President, Acquisitions and Development The Trump

>>Organization

>>725 Fifth Avenue | New York, NY | 10022 p. 212.836.3252 | m.

>>646.315.4698 | f. 212.836.3202 dorowitz@trumporg.com

>>| trump.com

>>

>>-----Original Message-----

>>From: scanner@trumporg.com [<mailto:scanner@trumporg.com>]

>>Sent: Monday, May 12, 2014 6:06 PM

>>To: David Orowitz

>>Subject: Message from "25-CopierColor-Right"

>>

>>This E-mail was sent from "25-CopierColor-Right" (MP C4503).

>>

>>Scan Date: 05.12.2014 18:06:06 (-0400) Queries to:

>>scanner@trumporg.com

>>

>>This e-mail message, and any attachments to it, are for the sole use

>>of the intended recipients, and may contain confidential and

>>privileged information. Any unauthorized review, use, disclosure or

>>distribution of this email message or its attachments is prohibited.

>>If you are not the intended recipient, please contact the sender by

>>reply email and destroy all copies of the original message. Please

>>note that any views or opinions presented in this email are solely

>>those of the author and do not necessarily represent those of the

>>company. Finally, while the company uses virus protection, the

>>recipient should check this email and any attachments for the presence

>>of viruses. The company accepts no liability for any damage caused by any virus transmitted by this email.

>>

>>

>>

>

>

>

RE_ Meeting to Discuss NPS Space and Museum_1.pdf

From: [David Orowitz](#)
To: [Robin Nixon](#)
Cc: [Carolyn Richard](#); [Danielle Breaux](#); [Kevin Terry - WPRA](#); [Brett Banks - WPT-C](#); edmund.newman@gsa.gov; [Andrew Weiss](#); [Stephen Dalton](#)
Subject: RE: Meeting to Discuss NPS Space and Museum
Date: Wednesday, May 14, 2014 4:25:15 PM

Great. Thanks, Robin. Please let us know as soon as you can and we will make sure our team is there.

Dave

David Orowitz
Senior Vice President, Acquisitions and Development
The Trump Organization
725 Fifth Avenue | New York, NY | 10022
p. 212.836.3252 | m. 646.315.4698 | f. 212.836.3202
dorowitz@trumporg.com | trump.com

From: Robin Nixon [mailto:robin_nixon@nps.gov]
Sent: Tuesday, May 13, 2014 10:22 AM
To: David Orowitz
Cc: Carolyn Richard; Danielle Breaux; Kevin Terry - WPRA; Brett Banks - WPT-C; edmund.newman@gsa.gov; Andrew Weiss; Stephen Dalton
Subject: Re: Meeting to Discuss NPS Space and Museum

Will get back to you ASAP; I'm sure we can get one of those dates to work.

Sent from my iPad

On May 13, 2014, at 9:43 AM, David Orowitz <dorowitz@trumporg.com> wrote:

Carolyn and Robin,

Hope all is well. I wanted to see if we could get a meeting in the calendar for June 10th (ideally afternoon) or 12th (ideally morning). The agenda would be as follows:

- 1) Review the updates to the plans for the build-out of NPS space
- 2) Discuss the overall concept and themes for the museum with our consultant (Char Lyons) and the division of content between the areas that will be fit-out by Trump and by NPS

I think that we should probably schedule 90 minutes (with some flexibility to go over a bit) to give us time to do brainstorming and make sure that we cover everything. Please let me know if there are some times that could work for you and your team.

Best,
Dave

David Orowitz
Senior Vice President, Acquisitions and Development

The Trump Organization
725 Fifth Avenue | New York, NY | 10022
p. 212.836.3252 | m. 646.315.4698 | f. 212.836.3202
dorowitz@trumporg.com | trump.com

This e-mail message, and any attachments to it, are for the sole use of the intended recipients, and may contain confidential and privileged information. Any unauthorized review, use, disclosure or distribution of this email message or its attachments is prohibited. If you are not the intended recipient, please contact the sender by reply email and destroy all copies of the original message. Please note that any views or opinions presented in this email are solely those of the author and do not necessarily represent those of the company. Finally, while the company uses virus protection, the recipient should check this email and any attachments for the presence of viruses. The company accepts no liability for any damage caused by any virus transmitted by this email.

RE_ Meeting to Discuss NPS Space and Museum(1).pdf

From: [David Orowitz](#)
To: [Robin Nixon](#)
Cc: [Carolyn Richard](#); [Danielle Breaux](#); [Kevin Terry - WPRA](#); [Brett Banks - WPT-C](#); edmund.newman@gsa.gov; [Andrew Weiss](#); [Stephen Dalton](#)
Subject: RE: Meeting to Discuss NPS Space and Museum
Date: Friday, May 16, 2014 12:21:31 PM

Robin,

Hope all is well. I was speaking to our consultant and we wanted to confirm that there was a plan for how the existing materials were going to be stored. Though some of them are probably beyond their useful life, we think that there is a lot that we could potentially use (either in NPS's space or Trump's museum space). Is there a plan for storing these materials? We can also help with this, but just wanted to make sure that we were planning for it.

Please also let me know about dates. I am going to be travelling after Monday next week and want to make sure that we can get all of our folks to the meeting who need to come in from out of town.

Thanks,
Dave

David Orowitz
Senior Vice President, Acquisitions and Development
The Trump Organization
725 Fifth Avenue | New York, NY | 10022
p. 212.836.3252 | m. 646.315.4698 | f. 212.836.3202
dorowitz@trumporg.com | trump.com

From: Robin Nixon [mailto:robin_nixon@nps.gov]
Sent: Tuesday, May 13, 2014 10:22 AM
To: David Orowitz
Cc: Carolyn Richard; Danielle Breaux; Kevin Terry - WPRA; Brett Banks - WPT-C; edmund.newman@gsa.gov; Andrew Weiss; Stephen Dalton
Subject: Re: Meeting to Discuss NPS Space and Museum

Will get back to you ASAP; I'm sure we can get one of those dates to work.

Sent from my iPad

On May 13, 2014, at 9:43 AM, David Orowitz <dorowitz@trumporg.com> wrote:

Carolyn and Robin,

Hope all is well. I wanted to see if we could get a meeting in the calendar for June 10th (ideally afternoon) or 12th (ideally morning). The agenda would be as follows:

- 1) Review the updates to the plans for the build-out of NPS space
- 2) Discuss the overall concept and themes for the museum with our consultant (Char Lyons) and the division of content between the areas that will be fit-out by Trump and by NPS

I think that we should probably schedule 90 minutes (with some flexibility to go over a bit) to give us time to do brainstorming and make sure that we cover everything. Please let me know if there are some times that could work for you and your team.

Best,
Dave

David Orowitz

Senior Vice President, Acquisitions and Development
The Trump Organization
725 Fifth Avenue | New York, NY | 10022
p. 212.836.3252 | m. 646.315.4698 | f. 212.836.3202
dorowitz@trumporg.com | trump.com

This e-mail message, and any attachments to it, are for the sole use of the intended recipients, and may contain confidential and privileged information. Any unauthorized review, use, disclosure or distribution of this email message or its attachments is prohibited. If you are not the intended recipient, please contact the sender by reply email and destroy all copies of the original message. Please note that any views or opinions presented in this email are solely those of the author and do not necessarily represent those of the company. Finally, while the company uses virus protection, the recipient should check this email and any attachments for the presence of viruses. The company accepts no liability for any damage caused by any virus transmitted by this email.

Re_ Meeting to Discuss NPS Space and Museum(1)_1.pdf

From: [Nixon, Robin](#)
To: [David Orowitz](#)
Cc: [Carolyn Richard](#); [Danielle Breaux](#); [Kevin Terry - WPRA](#); [Brett Banks - WPT-C](#); edmund.newman@gsa.gov; [Andrew Weiss](#); [Stephen Dalton](#)
Subject: Re: Meeting to Discuss NPS Space and Museum
Date: Friday, May 16, 2014 1:15:48 PM

Please refer to Carolyn as far as storage of materials from OPOT; I know there is a plan, I just don't know what it is!!

June 12th works better for us: will 10am-12pm work?

Robin Nixon
Chief of Partnerships
National Mall and Memorial Parks
National Park Service
900 Ohio Drive, SW
Washington, DC 20024
202-245-4710 (ofc)
202-738-7956 (cell)
robin_nixon@nps.gov

On Fri, May 16, 2014 at 2:22 PM, David Orowitz <dorowitz@trumporg.com> wrote:

Robin,

Hope all is well. I was speaking to our consultant and we wanted to confirm that there was a plan for how the existing materials were going to be stored. Though some of them are probably beyond their useful life, we think that there is a lot that we could potentially use (either in NPS's space or Trump's museum space). Is there a plan for storing these materials? We can also help with this, but just wanted to make sure that we were planning for it.

Please also let me know about dates. I am going to be travelling after Monday next week and want to make sure that we can get all of our folks to the meeting who need to come in from out of town.

Thanks,

Dave

David Orowitz

Senior Vice President, Acquisitions and Development

The Trump Organization

725 Fifth Avenue | New York, NY | 10022
p. 212.836.3252 | m. 646.315.4698 | f. 212.836.3202

dorowitz@trumporg.com | trump.com

From: Robin Nixon [mailto:robin_nixon@nps.gov]

Sent: Tuesday, May 13, 2014 10:22 AM

To: David Orowitz

Cc: Carolyn Richard; Danielle Breaux; Kevin Terry - WPRA; Brett Banks - WPT-C;
edmund.newman@gsa.gov; Andrew Weiss; Stephen Dalton

Subject: Re: Meeting to Discuss NPS Space and Museum

Will get back to you ASAP; I'm sure we can get one of those dates to work.

Sent from my iPad

On May 13, 2014, at 9:43 AM, David Orowitz <dorowitz@trumporg.com> wrote:

Carolyn and Robin,

Hope all is well. I wanted to see if we could get a meeting in the calendar for June 10th (ideally afternoon) or 12th (ideally morning). The agenda would be as follows:

- 1) Review the updates to the plans for the build-out of NPS space
- 2) Discuss the overall concept and themes for the museum with our consultant (Char Lyons) and the division of content between the areas that will be fit-out by Trump and by NPS

I think that we should probably schedule 90 minutes (with some flexibility to go over a bit) to give us time to do brainstorming and make sure that we cover everything. Please let me know if there are some times that could work for you and your team.

Best,

Dave

David Orowitz

Senior Vice President, Acquisitions and Development

The Trump Organization

725 Fifth Avenue | New York, NY | 10022
p. 212.836.3252 | m. 646.315.4698 | f. 212.836.3202

dorowitz@trumporg.com | trump.com

This e-mail message, and any attachments to it, are for the sole use of the intended recipients, and may contain confidential and privileged information. Any unauthorized review, use, disclosure or distribution of this email message or its attachments is prohibited. If you are not the intended recipient, please contact the sender by reply email and destroy all copies of the original message. Please note that any views or opinions presented in this email are solely those of the author and do not necessarily represent those of the company. Finally, while the company uses virus protection, the recipient should check this email and any attachments for the presence of viruses. The company accepts no liability for any damage caused by any virus transmitted by this email.

RE_ Meeting to Discuss NPS Space and Museum(2).pdf

From: [David Orowitz](#)
To: [Nixon, Robin](#)
Cc: [Carolyn Richard](#); [Danielle Breaux](#); [Kevin Terry - WPRA](#); [Brett Banks - WPT-C](#); edmund.newman@gsa.gov; [Andrew Weiss](#); [Stephen Dalton](#)
Subject: RE: Meeting to Discuss NPS Space and Museum
Date: Friday, May 16, 2014 2:29:05 PM

Robin - It should work for our team. I will follow with an invitation. Should we meet at the Old Post Office so we can walk the space and discuss if necessary? We have a construction office where we can discuss.

Carolyn – We can discuss the details on the existing materials in our June meeting, but if there is a way that we can help in the meantime please let us know.

Best,
Dave

David Orowitz
Senior Vice President, Acquisitions and Development
The Trump Organization
725 Fifth Avenue | New York, NY | 10022
p. 212.836.3252 | m. 646.315.4698 | f. 212.836.3202
dorowitz@trumporg.com | trump.com

From: Nixon, Robin [mailto:robin_nixon@nps.gov]
Sent: Friday, May 16, 2014 3:15 PM
To: David Orowitz
Cc: Carolyn Richard; Danielle Breaux; Kevin Terry - WPRA; Brett Banks - WPT-C; edmund.newman@gsa.gov; Andrew Weiss; Stephen Dalton
Subject: Re: Meeting to Discuss NPS Space and Museum

Please refer to Carolyn as far as storage of materials from OPOT; I know there is a plan, I just don't know what it is!!

June 12th works better for us: will 10am-12pm work?

Robin Nixon
Chief of Partnerships
National Mall and Memorial Parks
National Park Service
900 Ohio Drive, SW
Washington, DC 20024
202-245-4710 (ofc)
202-738-7956 (cell)
robin_nixon@nps.gov

On Fri, May 16, 2014 at 2:22 PM, David Orowitz <dorowitz@trumporg.com> wrote:
Robin,

Hope all is well. I was speaking to our consultant and we wanted to confirm that there was a plan for how the existing materials were going to be stored. Though some of them are probably beyond their useful life, we think that there is a lot that we could potentially use (either in NPS's space or Trump's museum space). Is there a plan for storing these materials? We can also help with this, but just wanted to make sure that we were planning for it.

Please also let me know about dates. I am going to be travelling after Monday next week and want to make sure that we can get all of our folks to the meeting who need to come in from out of town.

Thanks,
Dave

David Orowitz
Senior Vice President, Acquisitions and Development
The Trump Organization
725 Fifth Avenue | New York, NY | 10022
p. 212.836.3252 | m. 646.315.4698 | f. 212.836.3202
dorowitz@trumporg.com | trump.com

From: Robin Nixon [mailto:robin_nixon@nps.gov]
Sent: Tuesday, May 13, 2014 10:22 AM
To: David Orowitz
Cc: Carolyn Richard; Danielle Breaux; Kevin Terry - WPRA; Brett Banks - WPT-C; edmund.newman@gsa.gov; Andrew Weiss; Stephen Dalton
Subject: Re: Meeting to Discuss NPS Space and Museum

Will get back to you ASAP; I'm sure we can get one of those dates to work.

Sent from my iPad

On May 13, 2014, at 9:43 AM, David Orowitz <dorowitz@trumporg.com> wrote:

Carolyn and Robin,

Hope all is well. I wanted to see if we could get a meeting in the calendar for June 10th (ideally afternoon) or 12th (ideally morning). The agenda would be as follows:

- 1) Review the updates to the plans for the build-out of NPS space
- 2) Discuss the overall concept and themes for the museum with our consultant (Char Lyons) and the division of content between the areas that will be fit-out by Trump and by NPS

I think that we should probably schedule 90 minutes (with some flexibility to go over a bit) to give us time to do brainstorming and make sure that we cover everything. Please let me know if there are some times that could work for you and your team.

Best,
Dave

David Orowitz

Senior Vice President, Acquisitions and Development
The Trump Organization
725 Fifth Avenue | New York, NY | 10022
p. 212.836.3252 | m. 646.315.4698 | f. 212.836.3202
dorowitz@trumporg.com | trump.com

This e-mail message, and any attachments to it, are for the sole use of the intended recipients, and may contain confidential and privileged information. Any unauthorized review, use, disclosure or distribution of this email message or its attachments is prohibited. If you are not the intended recipient, please contact the sender by reply email and destroy all copies of the original message. Please note that any views or opinions presented in this email are solely those of the author and do not necessarily represent those of the company. Finally, while the company uses virus protection, the recipient should check this email and any attachments for the presence of viruses. The company accepts no liability for any damage caused by any virus transmitted by this email.

Meeting to Discuss NPS Space and OPO Museum.pdf

From: [David Orowitz](#)
To: [Nixon, Robin](#); [Carolyn Richard](#); [Danielle Breaux](#); [Kevin Terry - WPRA](#); [Brett Banks - WPT-C](#); edmund.newman@gsa.gov; [Andrew Weiss](#); [Stephen Dalton](#); clyon@cattiyondesign.com
Subject: Meeting to Discuss NPS Space and OPO Museum

This e-mail message, and any attachments to it, are for the sole use of the intended recipients, and may contain confidential and privileged information. Any unauthorized review, use, disclosure or distribution of this email message or its attachments is prohibited. If you are not the intended recipient, please contact the sender by reply email and destroy all copies of the original message. Please note that any views or opinions presented in this email are solely those of the author and do not necessarily represent those of the company. Finally, while the company uses virus protection, the recipient should check this email and any attachments for the presence of viruses. The company accepts no liability for any damage caused by any virus transmitted by this email.

Accepted_ Meeting to Discuss NPS Space and OPOpdf

From: [Google Calendar](#) on behalf of [Carolyn Richard](#)
To: [David Orowitz](#)
Subject: Accepted: Meeting to Discuss NPS Space and OPO Museum @ Thu Jun 12, 2014 10am - 12pm
(carolyn_richard@nps.gov)
Attachments: [invite.ics](#)

Carolyn Richard has accepted this invitation.
Meeting to Discuss NPS Space and OPO Museum

When Thu Jun 12, 2014 10am – 12pm Eastern Time
Where Old Post Office (1100 Penn Avenue) Room 207 (HYPERLINK "[http://maps.google.com/maps?q=Old+Post+Office+\(1100+Penn+Avenue\)+Room+207&hl=en](http://maps.google.com/maps?q=Old+Post+Office+(1100+Penn+Avenue)+Room+207&hl=en)" map)

Calendar carolyn_richard@nps.gov

Who • David Orowitz - organizer

- Carolyn Richard - creator
- Stephen Dalton
- Danielle Breaux
- Andrew Weiss
- Kevin Terry - WPRA
- Nixon, Robin
- edmund.newman@gsa.gov
- clyon@cattlyondesign.com
- Brett Banks - WPT-C

Invitation from HYPERLINK "<https://www.google.com/calendar/>" Google Calendar

You are receiving this courtesy email at the account dorowitz@trumporg.com because you are an attendee of this event.
To stop receiving future notifications for this event, decline this event. Alternatively you can sign up for a Google account at <https://www.google.com/calendar/> and control your notification settings for your entire calendar.

Accepted_ Meeting to Discuss NPS Space and OPO ...(1).pdf

From: [Google Calendar](#) on behalf of [Robin Nixon](#)
To: [David Orowitz](#)
Subject: Accepted: Meeting to Discuss NPS Space and OPO Museum @ Thu Jun 12, 2014 10am - 12pm
(robin_nixon@nps.gov)
Attachments: [invite.ics](#)

Robin Nixon has accepted this invitation.
Meeting to Discuss NPS Space and OPO Museum

When Thu Jun 12, 2014 10am – 12pm Eastern Time
Where Old Post Office (1100 Penn Avenue) Room 207 (HYPERLINK "[http://maps.google.com/maps?q=Old+Post+Office+\(1100+Penn+Avenue\)+Room+207&hl=en](http://maps.google.com/maps?q=Old+Post+Office+(1100+Penn+Avenue)+Room+207&hl=en)" map)

Calendar robin_nixon@nps.gov

Who • David Orowitz - organizer

- Robin Nixon - creator
- Brett Banks - WPT-C
- clyon@cattlyondesign.com
- Carolyn Richard
- Danielle Breaux
- edmund.newman@gsa.gov
- Kevin Terry - WPR
- Stephen Dalton
- Andrew Weiss

Invitation from HYPERLINK "<https://www.google.com/calendar/>" Google Calendar

You are receiving this courtesy email at the account dorowitz@trumporg.com because you are an attendee of this event.
To stop receiving future notifications for this event, decline this event. Alternatively you can sign up for a Google account at <https://www.google.com/calendar/> and control your notification settings for your entire calendar.

Security Vault Treatment Card.pdf

From: [Stephen Dalton](#)
To: [Audrey Tepper](#); [Andrew \(OP\) Lewis](#)
Cc: [John Cullinane](#); [Andrew Weiss](#); [David Orowitz](#); [Durwood Dixon](#)
Subject: Security Vault Treatment Card
Date: Friday, June 06, 2014 8:13:20 AM
Attachments: [OPO Security Vaults.pdf](#)

As John I think has told you, we have located a number of Security Vaults on many floors now that the building is empty. John has prepared the attached Treatment Card that I have also sent Fed Ex to Andy Lewis last night so you have originals. Please add this to the other cards. Thank you.

Stephen H. Dalton, AIA
The Trump Old Post Office LLC
1100 Pennsylvania Avenue, NW
Room 207
Washington, DC 20007
Tel 202-309-3945
Fax 202-318-0067

This e-mail message, and any attachments to it, are for the sole use of the intended recipients, and may contain confidential and privileged information. Any unauthorized review, use, disclosure or distribution of this email message or its attachments is prohibited. If you are not the intended recipient, please contact the sender by reply email and destroy all copies of the original message. Please note that any views or opinions presented in this email are solely those of the author and do not necessarily represent those of the company. Finally, while the company uses virus protection, the recipient should check this email and any attachments for the presence of viruses. The company accepts no liability for any damage caused by any virus transmitted by this email.

OPO Security Vaults.pdf

**HISTORIC PRESERVATION CERTIFICATION APPLICATION PART 2
DESCRIPTION OF REHABILITATION**



Photo # T-160 and # T161 Typical vaults and vault doors located at selected offices in the Old Post Office. See schedule to the right for locations.

Proposed Treatment

As part of the introduction of guest rooms into the Old Post Office, the existing vault spaces will be integrated into guest rooms. The vault doors will be removed and delivered to GSA for disposition.

NPS Project Number

NUMBER

Property name Old Post Office

Property address 1100 Pennsylvania Avenue, Washington, DC

E. Detailed description of rehabilitation work

Feature Security Vaults

Date of Feature 1899
1979

Significance: Contributing Non-contributing Not Historic

As part of the original design, vaults were installed in conjunction with selected offices in the Old Post Office. The vaults were constructed of plaster finished reinforced masonry, with full size, hinged vault doors. Neither the vaults nor the vault doors are decorative.

As part of the 1979 renovations of the building the vaults were integrated into the office design, with most serving as storage space.

Photo Numbers

Effect: NE NAE AE

Drawing Numbers

Vault Locations:

Room. 201/202, 203, 216/217, 301/302, 303. 401/402, 403, 410, 420, 519, 520, and 618

Meeting to Discuss NPS Space and OPO Museum(1).pdf

From: [David Orowitz](#)
To: ["Nixon, Robin"](#); [Carolyn Richard](#); [Danielle Breaux](#); [Kevin Terry - WPRA](#); [Brett Banks - WPT-C](#); [edmund.newman@gsa.gov](#); [Andrew Weiss](#); [Stephen Dalton](#); [clyon@cattiyondesign.com](#); [Oksana Chernyaeva](#)
Cc: ["Danielle Breaux - WPS-C"](#)
Subject: Meeting to Discuss NPS Space and OPO Museum

This e-mail message, and any attachments to it, are for the sole use of the intended recipients, and may contain confidential and privileged information. Any unauthorized review, use, disclosure or distribution of this email message or its attachments is prohibited. If you are not the intended recipient, please contact the sender by reply email and destroy all copies of the original message. Please note that any views or opinions presented in this email are solely those of the author and do not necessarily represent those of the company. Finally, while the company uses virus protection, the recipient should check this email and any attachments for the presence of viruses. The company accepts no liability for any damage caused by any virus transmitted by this email.

Meeting to Discuss NPS Space and OPO Museum(2).pdf

From: [David Orowitz](#)
To: ["Nixon, Robin"](#); [Carolyn Richard](#); [Danielle Breaux](#); [Kevin Terry - WPR](#); [Brett Banks - WPT-C](#); [edmund.newman@gsa.gov](#); [Andrew Weiss](#); [Stephen Dalton](#); [clyon@cattiyondesign.com](#); [Oksana Chernyaeva](#); ["Danielle Breaux - WPS-C"](#)
Subject: Meeting to Discuss NPS Space and OPO Museum
Date: Monday, June 09, 2014 4:59:21 PM
Attachments: [TOPO Museum Agenda 1.pdf](#)
[TOPO Museum Thematic Plan140612.pdf](#)

All,

We are looking forward to the meeting on Thursday at the Old Post Office. Please find attached an agenda as well as an initial Thematic Plan for the museum that Trump will be building. Please note that this is very preliminary and will evolve significantly with development, but we thought it was helpful to give everyone context of the general direction in which we are heading. In addition, we will also have full sized plans and proposed finishes for the spaces that NPS will operate for everyone to view at the meeting.

I look forward to seeing all of you later this week.

Best,
Dave

David Orowitz
Senior Vice President, Acquisitions and Development
The Trump Organization
725 Fifth Avenue | New York, NY | 10022
p. 212.836.3252 | m. 646.315.4698 | f. 212.836.3202
dorowitz@trumporg.com | trump.com

This e-mail message, and any attachments to it, are for the sole use of the intended recipients, and may contain confidential and privileged information. Any unauthorized review, use, disclosure or distribution of this email message or its attachments is prohibited. If you are not the intended recipient, please contact the sender by reply email and destroy all copies of the original message. Please note that any views or opinions presented in this email are solely those of the author and do not necessarily represent those of the company. Finally, while the company uses virus protection, the recipient should check this email and any attachments for the presence of viruses. The company accepts no liability for any damage caused by any virus transmitted by this email.

TOPO Museum Agenda 1.pdf



Trump Old Post Office Museum

Design Kick-Off—Meeting 1 6.12.14

Review of Renovated Spaces and Finishes

Lower Level Museum
Levels 9-12

Visitor Experience

(Trump) Museum
(NPS) Clock Tower Museum

Thematic Plan for Trump Museum

Floor Plan Review
Sketch-Up Model

Assets

2D Materials: Photos, Drawings, Broadsides, Posters
3D Materials: Original Postal Equipment, Artifacts of the 70s & 80s

Possible Sources:

General Services Administration, National Capital Region Technical Resource Center
Library of Congress, Prints and Photographs Division
USPS Corporate Research Library and Archives
The Historical Society of Washington, DC, Kiplinger Research Library
Postal Museum
Livable DC
Other Sources?

Tracking Materials with a Database—Filemaker Pro

Safety / Security / Logistics

Entry/Exit
Traffic Flow at Peak Times
Staffing
Signage Needs

TOPO Museum Thematic Plan140612.pdf



CATT LYON
DESIGN + WAYFINDING

53 W Jackson Blvd., #362
Chicago, Illinois 60604
Voice 312.435.2855

1375 Broadway, Fl. 3
New York, NY 10018
Voice 212.226.2626

212 Ludlow Ave.
Cincinnati, Ohio 45220
Voice 513.221.3500

www.cattlyondesign.com

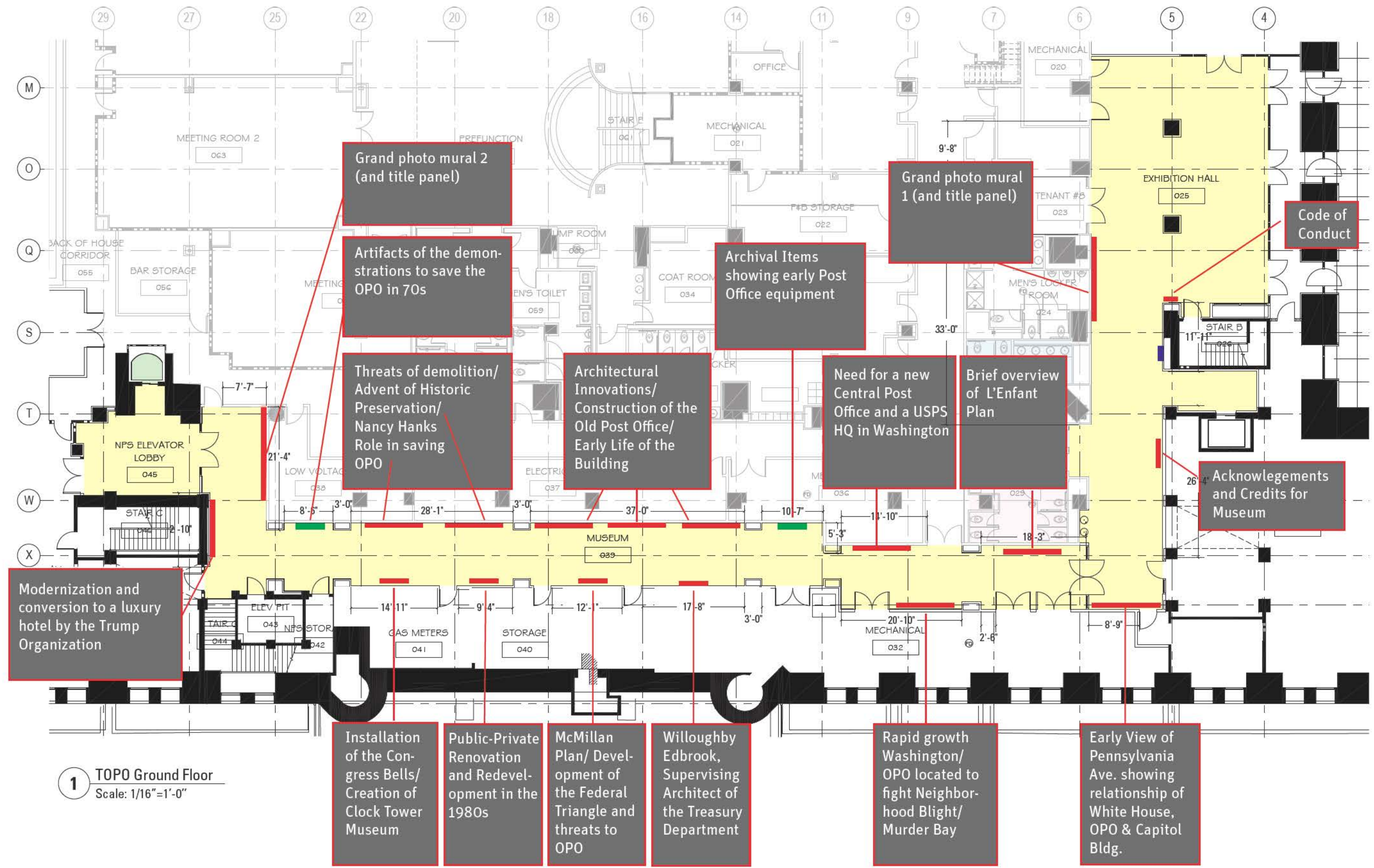

Grand photo mural 2
(and title panel)

Grand photo mural 1
(and title panel)

Code of
Conduct

Artifacts of the demon-
strations to save the
OPO in 70s

Archival Items
showing early Post
Office equipment

Threats of demolition/
Advent of Historic
Preservation/
Nancy Hanks
Role in saving
OPO

Architectural
Innovations/
Construction of the
Old Post Office/
Early Life of the
Building

Need for a new
Central Post
Office and a USPS
HQ in Washington

Brief overview
of L'Enfant
Plan

Acknowledgements
and Credits for
Museum

Modernization and
conversion to a luxury
hotel by the Trump
Organization

Installation of the Con-
gress Bells/
Creation of
Clock Tower
Museum

Public-Private
Renovation
and Redevel-
opment in the
1980s

McMillan
Plan/ Devel-
opment of
the Federal
Triangle and
threats to
OPO

Willoughby
Edbrook,
Supervising
Architect of
the Treasury
Department

Rapid growth
Washington/
OPO located to
fight Neighbor-
hood Blight/
Murder Bay

Early View of
Pennsylvania
Ave. showing
relationship of
White House,
OPO & Capitol
Bldg.

1 TOPO Ground Floor
Scale: 1/16"=1'-0"

NOT FOR CONSTRUCTION

Revisions

Trump Old Post Office
1100 Pennsylvania Ave, NW
Washington, DC 20004

Schematic Design

06/12/2014

Thematic Plan

GS1-01

© 2014 Catt Lyon Design. All Rights Reserved

Accepted_ Meeting to Discuss NPS Space and OPO ...(2).pdf

From: [Google Calendar](#) on behalf of [Carolyn Richard](#)
To: [David Orowitz](#)
Subject: Accepted: Meeting to Discuss NPS Space and OPO Museum @ Thu Jun 12, 2014 10am - 12pm
(carolyn_richard@nps.gov)
Attachments: [invite.ics](#)

Carolyn Richard has accepted this invitation.
Meeting to Discuss NPS Space and OPO Museum

When Thu Jun 12, 2014 10am – 12pm Eastern Time
Where Old Post Office (1100 Penn Avenue) Room 207 - Enter at south entrance (off 12th Street) (HYPERLINK "[http://maps.google.com/maps?q=Old+Post+Office+\(1100+Penn+Avenue\)+Room+207+-+Enter+at+south+entrance+\(off+12th+Street\)&hl=en](http://maps.google.com/maps?q=Old+Post+Office+(1100+Penn+Avenue)+Room+207+-+Enter+at+south+entrance+(off+12th+Street)&hl=en)" map)

Calendar carolyn_richard@nps.gov

Who • David Orowitz - organizer

- Carolyn Richard - creator
- Stephen Dalton
- Brett Banks - WPT-C
- Oksana Chernyaeva
- Kevin Terry - WPR
- 'Nixon, Robin'
- edmund.newman@gsa.gov
- Andrew Weiss
- clyon@cattlyondesign.com
- Danielle Breaux
- 'Danielle Breaux - WPS-C' - optional

Invitation from HYPERLINK "<https://www.google.com/calendar/>" Google Calendar

You are receiving this courtesy email at the account dorowitz@trumporg.com because you are an attendee of this event.

To stop receiving future notifications for this event, decline this event. Alternatively you can sign up for a Google account at <https://www.google.com/calendar/> and control your notification settings for your entire calendar.

Fwd_ Attached Image.pdf

From: [Tepper, Audrey](#)
To: [David Orowitz](#)
Cc: [Hany Hassan](#); [John Cullinane](#); [Nancy Witherell](#); [Andrew Lewis](#); [Brian Goeken](#)
Subject: Fwd: Attached Image
Date: Thursday, June 26, 2014 3:55:06 PM
Attachments: [0181_001.pdf](#)

David:

Attached is a scanned copy of the Part 2 conditional approval for the Old Post Office in Washington, DC (NPS Project No. 30491)...the original will follow in the mail. Although this document is lengthy, the majority of what is requested is clarification where we found gaps in the submitted information. Feel free to get in touch should you have questions.

Thank you very much for working with the National Park Service to bring this exciting project to fruition. We look forward to more continued collaboration.

Sincerely,

Audrey Tepper

----- Forwarded message -----

From: <CR_Scans@nps.gov>
Date: 2014-06-26 17:46 GMT-04:00
Subject: Attached Image
To: Audrey <audrey_tepper@nps.gov>

--

Audrey T. Tepper - LEED Green Associate
Historical Architect
National Park Service
Technical Preservation Services Branch
1201 Eye Street, NW - Org. 2200
Washington, DC 20005
202-354-2027
202-371-1616 (FAX)
audrey_tepper@nps.gov

0181_001.pdf

UNITED STATES DEPARTMENT OF THE INTERIOR
NATIONAL PARK SERVICE

OMB Approved
No. 1024-0009
Form 10-168
Rev. 2011

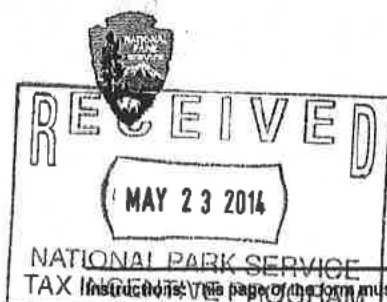

HISTORIC PRESERVATION CERTIFICATION APPLICATION
PART 2 – DESCRIPTION OF REHABILITATION

NPS Project Number 30491

Instructions: The page of the form must appear exactly as below and must bear the owner's original signature. Other sections may be expanded as needed or continued on blank pages. The National Park Service certification decision is based on the descriptions in this application form. In the event of any discrepancy between the application form and other, supplementary material submitted with it (such as architectural plans, drawings and specifications), the application form takes precedence. A copy of this form will be provided to the Internal Revenue Service.

1. Property Name Old Post Office and Clock Tower
Street 1100 Pennsylvania Avenue, NW
City Washington County _____ State DC Zip 20004
Name of Historic District N/A

- Listed Individually in the National Register of Historic Places; date of listing April 11, 1973
 Located in a Registered Historic District; name of district _____
 Part 1 – Evaluation of Significance submitted? Date submitted _____ Date of certification _____

2. Data on building and rehabilitation project
Date of construction 1891-1899 Cost of rehabilitation (estimated) ~\$160,000,000
Type of construction Steel Frame/Masonry Floor area before / after rehabilitation ~440,000 / ~440,000
Start date (estimated) June 2014 Use(s) before / after rehabilitation Office/Retail / Hotel/Retail
Completion date (estimated) July 2016 Number of housing units before / after rehabilitation N/A / N/A
This application covers phase number 1&2 of 2 phases Number of low-moderate income housing units before / after rehabilitation N/A / N/A

3. Project Contact (If different from Owner)
Name David Orowitz
Street 725 5th Avenue City New York
State NY Zip 10022 Telephone 212-836-3252

4. Owner
I hereby attest that the information I have provided is, to the best of my knowledge, correct and that I own the property described above. I understand that falsification of factual representations in this application is subject to criminal sanctions of up to \$10,000 in fines or imprisonment for up to five years pursuant to 18 USC 1001.
Name Trump Old Post Office LLC / Ivanka Trump Signature  Date 4/4/14
Organization Trump Old Post Office LLC Social Security OR Taxpayer ID Number 452671841
Street 60 Crossways Park Dr. West, Ste 301 City Woodbury
State NY Zip 11797 Telephone 212-715-7256

NPS Official Use Only

- The National Park Service has reviewed the Historic Certification Application – Part 2 for the above-named property and has determined that:
- the rehabilitation described herein is consistent with the historic character of the property and, where applicable, with the district in which it is located and that the project meets the Secretary of the Interior's Standards for Rehabilitation. This letter is a preliminary determination only, since a formal certification of rehabilitation can be issued only to the owner of a "certified historic structure" after rehabilitation work is complete.
- the rehabilitation or proposed rehabilitation will meet the Secretary of the Interior's Standards for Rehabilitation if the attached conditions are met.
- the rehabilitation described herein is not consistent with the historic character of the property or the district in which it is located and that the project does not meet the Secretary of the Interior's Standards for Rehabilitation.

6-26-14 Date
Audrey T. Tepper National Park Service Authorized Signature
AUDREY T. TEPPER
NPS-TPS (202) 354-2027

See Attachments

UNITED STATES DEPARTMENT OF THE INTERIOR
NATIONAL PARK SERVICE

CONDITIONS SHEET

Historic Preservation Certification Application – *Part 2 Conditional Approval*

Property name: The Old Post Office Project Number: 30491

Property address: 1100 Pennsylvania Avenue, NW, Washington, DC

The National Park Service has determined that this project will meet the Secretary of the Interior Standards for Rehabilitation if the condition(s) listed in the box above are met.

Condition Sheet 1 of 7

General Notes:

Large Size of Submittal: Due to the large size of the Old Post Office and its change in use, the amount of documentation submitted with Part 2 of this application is extensive. Please note that regulations governing the Federal Historic Preservation Tax Incentives program mandate that the Part 2 narrative/text of the application - in the case of this project, "The Treatment Cards" - takes precedent over all other submitted material (drawings; photographs; reports, etc.). As a result, the narrative must be comprehensive, with all proposed treatments for the interior, exterior and/or site addressed in writing, as opposed to illustrated in the drawings only. Please bring all present and future treatments to our attention so nothing is inadvertently overlooked. Additional information in amendment form should be forwarded for review and approval to the National Park Service, through the DC Historic Preservation Office, prior to construction.

Numbering of Documents: The submitted "Treatment Cards" were not numbered, except for the numbering of individual images on each card. When these cards are referenced below, the number of the photographs will be used to identify each sheet - for example, "Treatment Card 12" contains "Photo T-12". In all future submittals and for ease of review, please number each page of the each document.

1) Windows:

The Part 2 application indicates that treatment of windows will be based upon a forthcoming window survey. As such, these comments *do not* address windows in any detail. Further consultation is necessary to determine the appropriate treatments for window repair and replacement once the results of the window survey are provided to the District of Columbia Historic Preservation Office (DC HPO) and the National Park Service (NPS).

Should it be demonstrated that some windows are beyond repair, replacement windows must match the size, materials, design, proportions and profiles of the existing windows. Comparable detailed drawings of both the existing and any proposed replacement windows should be reviewed and approved by the DC HPO and the NPS before proceeding with any window replacements.

2) Doors:

a) Exterior Entry Doors:

i) Main Entry Doors:

Replacement of the non-historic entry doors (not including historic door frames, sidelights, transoms etc.) on three sides of the building (Pennsylvania Avenue, 11th Street, 12th Street) and the introduction of new entry doors on C Street is permitted, provided further consultation is carried out to determine if the types and styles of the new doors are appropriate. Issues to be addressed include, but are not limited to, the design of replacement wood entry doors; the design and insertion of glass doors behind the wood doors; the choice of materials; and installation details.

Please note reinstating mid-height glass panels (as they exist today) in new doors is problematic. The current doors may stay in place, but if they are removed, they must be replaced with compatible new designs, which the doors with intermediate glass panels are not.

If wood entry doors are currently in place, then they should be replaced with wood doors; wood doors may be propped open with glass doors installed beyond. This is applicable at the 11th Street entrance, where only glass doors are proposed.

ii) **Arcade Commercial Entrances:**

Treatment Card 20 discusses the replacement of the doors along Pennsylvania Avenue that were added as part of the 1979 renovation. It is unclear from the drawings submitted how these new doors will appear. To comply with the Secretary's Standards, please provide additional information on the appearance of any new doors.

iii) **Service Door at 11th Street Areaway:**

No treatment card was provided for the design of the small service door that leads to the 11th Street areaway. This omission is likely accidental, but a design for this location is still required.

b) **Interior Doors:**

i) **Retail Doors (off main entry; off lobbies, off Pennsylvania Avenue; etc.):**

All historic doors leading to (or in the general area of) the new retail spaces must be retained, repaired and left in place. They may be propped open and augmented with new glass doors, provided designs for these assemblies are submitted for our review and approval *prior* to installation.

ii) **Historic Corridor/Guestroom/Suite Doors – 2nd through 9th Floors:**

General Comment: The insertion of new, compatible doors at guest room entries (samples of which were viewed by Andrew Lewis [DC HPO] and Audrey Tepper [NPS] on site May 29, 2014) meets the Secretary's Standards. Furthermore, the retention and the propping open of historic doors at existing vestibules, or at vestibules to be created, are permitted.

All other historic doors, which will not be replaced for guest room entries or permanently propped open, must be retained in place. These doors may be fixed, may have their hardware removed, may be covered with wallboard on the interior for fire separation, and may be covered with sheer curtains as per mock-ups installed on site, but they must remain in place and not be removed in their entirety. Together with their hardware, all historic doors that are removed at guest rooms must be carefully labeled to indicate their original locations and then stored *on site* in a climate-controlled area within the Old Post Office (not in the Annex); original doors that are removed from the premises will likely be lost. Please indicate where these features will be warehoused when this information becomes available. (e.g. A2.05, A2.35, A10.20, Treatment Cards 73 and 74).

3) **Cortile Corridors – Approval of Treatment(s):**

As per mock-ups reviewed by Andrew Lewis (DC HPO) and Audrey Tepper (NPS) on site, the installation of sheer fabric over historic doors and other corridor features, with opaque curtains to the sides, meets the Secretary's Standards.

4) **Historic Corner Suites (especially the 5th Floor former Postmaster General's Office):**

This conditional approval *does not* extend to the designs of all guest suites at corners (and elsewhere in the building). Revised plans and construction details of the 5th Floor suite were submitted to the NPS, but this documentation is at a small scale and it is difficult to determine where the accompanying details are referenced. Clarification is also required on how historic features and finishes unique to this area will be retained, repaired and left exposed. These are rare examples of the high level of ornamentation historically found on the interior of this landmarked building and as such, must be treated with great care. As a result, further consultation with the project team is required to fully assess what is proposed for the guest suites and to grant approval for their designs in accordance with the Secretary's Standards.

5) **Retail Areas and New Passageways (First Floor - Northeast and Northwest Corners):**

As stated in the Part 2 narrative, additional information on the designs of future retail spaces will be submitted once tenants are secured. In addition to this documentation, proposals for "passageways" leading to the Cortile are also required. Collectively, this amendment should include floor plans; finishes (wall, ceiling, and floor); treatments of historic and new doors; lighting; signage; location of seating areas; associated furniture; and any other pertinent information. (Treatment Cards 52, 53, 54, 56, 59, 111, 133, 134, 135 and 136)

Select areas of historic fabric remain in the former restaurant space in the Post Master's office on the first floor, specifically along the interior side of the Cortile corridor. In light of how few original features survive beyond corridors on the building's interior, care must be taken to save as much as possible of these original details. (Treatment Cards 133-136)

6) **Floor Plan Patterns/General Comment:**

On Drawings AD2.02 – AD2.09, large areas of the floor plans are shaded with a honeycomb pattern. What does this pattern represent? There is also cross-hatching on several floors plans – on the 6th floor plan for example (A2.36) – that is not identified. Please be careful on future submittals to key all patterns, shading, etc. used in the construction drawings; they are often unlabeled, which may not provide the information you wish to convey.

7) **Pennsylvania Avenue Plaza Paving:**

The treatment cards and plans indicate that the existing pavement treatment on Pennsylvania Avenue closest to the steps of the Old Post Office (i.e. brick, PADC-style pavers and granite details) will be replaced with granite. Please submit samples of any new materials used in this area. This allows us to may confirm that this new installation is compatible with the historic building and the decorative “flag artwork” pavers currently in place. (Dwgs. L103 and Treatment Card 2)

8) **Exterior Planters at 11th and C Streets:**

The “Fioriera Fesstonata” planters proposed for 11th and C Streets must be omitted from the scope of work because they are incompatible with this former post office. Please investigate other ways of blocking off this area; we recommend installing simple railings or low walls. The revised design for this location must be submitted for review and approval to the National Park Service, through the DC Historic Preservation Office, *prior* to installing any components. (Dwgs. L601, L602, L603, & L705)

9) **Annex:**

a) **Connection of Annex to Historic Building:**

Treatment Card 4 discusses the replacement of glass at the connection between the annex and the historic post office. Will changes be made to the current design? It is difficult to determine this from the drawings referenced in the narrative. Please clarify.

b) **Green Roof on Annex:**

Since no roof plan of the annex was included in the drawings set, it is impossible to determine where the installation of a green roof will occur. Although the annex itself is not historic, it is surrounded by historic buildings and this new amenity must be compatible. If the location for the green roof is acceptable, it may be installed provided it is not a highly visible new element. It must also have low profile plantings, as well as no visible vertical structures, furniture, umbrellas; railings; etc. Please design the roof in accordance with the guidance provided in the following National Park Service publications:

- “Adding Green Roofs to Historic Buildings to Enhance Their Sustainability and Energy Performance” - <http://www.nps.gov/tps/sustainability/new-technology/green-roofs.htm>
- Interpreting the Standards Bulletin 54 – *Installing Green Roofs on Historic Buildings*” - <http://www.nps.gov/tps/standards/applying-rehabilitation/its-bulletins/ITS54-GreenRoofs.pdf>

10) **Lighting:**

a) **Exterior Lighting:**

i) **Overall Exterior Lighting:**

In addition to the Commission of Fine Arts, the National Park Service and the DC Historic Preservation Office must be consulted when exterior lighting tests are conducted on site and must approve the final lighting design *prior* to installation.

ii) **Exterior Pole Lighting:**

It has been brought to our attention that the “pole lights” proposed for 11th Street are inconsistent with DC street lighting standards. This design may also be subject to District Department of Transportation (DDOT) approval. Please substitute accepted “Washington Globe” pole lights in lieu of the current proposal. For more information on local compliance, please consult Andrew Lewis at the DC HPO. (Dwg. L705)

iii) **Pennsylvania Avenue “Porch” Lighting Fixtures:**

Please submit designs for all replacement exterior lighting fixtures at the Pennsylvania Avenue entrance. (Treatment Card 23)

b) **Interior Lighting:**

i) **Lighting at Entries, Lobbies and Connecting Corridors:**

More information is required on the proposed lighting fixtures at the lobbies and the connecting

corridors surrounding the Cortile. These are some of the most important public spaces in the building, so compatible lighting fixtures should be installed. This information must be submitted for review and approval to the National Park Service, through the DC Historic Preservation Office, *prior* to purchasing fixtures.

11) **Signage Package:**

When the designs and locations of signage throughout the property (inside and outside) are finalized, this information must be submitted for review and approval to the National Park Service, through the DC Historic Preservation Office, *prior* to installation (or purchasing signs).

12) **Raised Access Floor:**

Drawing S-203 shows that an area on the 2nd Floor at the Pennsylvania Avenue, 11th Street, and 12th Street entrances and at the "Historic Board Room/Meeting Room/Library," will contain a "raised access floor." Before any work is undertaken, please clarify what this action entails so its compatibility can be assessed. (S-203)

13) **Beadboard Electric Line Chase:**

The beadboard chase at the side of the clock tower is a character-defining feature of the interior that should remain in place. We recommend reusing this component for utilitarian purposes. (Dwgs. AH2.02 – AH2.07 and Treatment Card 64)

14) **Masonry:**

General Comment: Given the importance of this historic structure, the project should employ the services of a qualified architectural conservator for treatment of the interior and exterior masonry. The National Park Service and DC Historic Preservation Office are available to evaluate any testing of products on site, or any replacement masonry if it is determined select areas are beyond repair.

a) **Cleaning:**

Cleaning of exterior masonry must be accomplished using the gentlest means possible without damaging the surface of the masonry. This work must be accomplished in accordance with the guidance provided in Preservation Brief 1, *Assessing Cleaning and Water-Repellent Treatments for Historic Masonry Buildings*. Specification and test cleaning samples should be reviewed and approved by the State Historic Preservation Office before proceeding with this work. Good overall and close-up color photographs of the masonry before and after cleaning must be submitted with the *Request for Certification of Completed Work* (Part 3).

Please note Treatment Card 30 states that the "JOS" system will be used to clean historic granite. In accordance with Standard 7 of the Secretary's Standards for Rehabilitation and "Preservation Brief 1" – see below* – the use of abrasive cleaning methods that damage historic stone is strictly prohibited. Please use the guidance below to select a more appropriate cleaning method for the granite and all other historic masonry. Revised cleaning treatments must be submitted to the National Park Service, through the DC Historic Preservation Office, *prior* to commencing work in site.

When cast iron features are sand-blasted to remove paint, care must be taken to protect surrounding historic masonry and other softer materials that may be adversely affected by this abrasive process.

*Standard 7 – "Chemical or physical treatments, such as sandblasting, that cause damage to historic materials shall not be used. The surface cleaning of structures, if appropriate, shall be undertaken using the gentlest means possible."

"Preservation Brief 1 – *Assessing Cleaning and Water-Repellent Treatments for Historic Masonry Buildings*" - <http://www.nps.gov/tps/how-to-preserve/briefs/1-cleaning-water-repellent.htm>

b) **Repointing:**

Repointing mortar must be done on an as-needed basis only and match the color, texture, strength, joint width, and

joint profile of the existing historic masonry. This work must be accomplished in accordance with the guidance provided in Preservation Brief 2, *Repointing Mortar Joints in Historic Masonry Buildings*. Specifications and repointing samples should be reviewed and approved by the State Historic Preservation Office before proceeding with this work. Good quality overall and close-up photographs of the masonry before and after repointing must be submitted with the *Request for Certification of Completed Work* (Part 3).

c) **Exterior Granite Veneer:**

Provided we have an opportunity to review the selected material for its compatibility, we will allow the use of a granite veneer in areas of the brick foundation that were exposed in the 1979 redo of the building. This information must be submitted to the National Park Service, through the District Historic Preservation Office, *prior* to installation. (Treatment Cards 12 and 29).

d) **Decorative Marble on First Floor:**

Treatment Card 44 states that interior marble will be "polished." What does this entail and what products will be used? The gentlest means possible must be made used so masonry is not damaged.

e) **Interior Corridor Stone:**

Plans suggest that a significant amount of historic stone at corridor walls and bases (Floors 2 – 9) is damaged and will be replaced. The Secretary's Standards require the retention and repair of as much historic architectural fabric as possible. Therefore, unless this damage is sufficiently documented and we determine replacement is merited – little information was provided in the application to this effect – this character-defining feature of the interior must be preserved rather than replaced. Please identify exactly where damaged stone exists; what types of deterioration is present; what repair methods are proposed; etc. This effort must be supplemented by photographs. If our evaluation reveals that replacement is necessary, additional information about the type(s) of replacement stone that are specified (including samples) must be provided to ensure its compatibility. (Dwgs. AH4.02 – AH4.09)

f) **Polychrome Marble Floors – First Floor:**

Historic marble floors on the first floor (lobbies; connecting corridors around the Cortile, etc.), which are polychromatic with inlaid decorative patterns, are character-defining features of the interior that must be retained, repaired and left exposed. As previously discussed on site and at project meetings, it is permissible to cover marble floors above this level with carpet runners (with black stone borders visible at the edges), but the first floor marble is considerably more distinctive and should be treated accordingly. (Treatment Cards 49 and 50)

g) **Carved Granite:**

Special care must be taken when cleaning and repairing decorative carved features on the interior and exterior of this important building. Good quality overall and close-up photographs of the carved masonry before and after repair (cleaning; repointing, etc.) must be submitted with the *Request for Certification of Completed Work* (Part 3).

h) **Affixing Signs and Lighting into Historic Masonry:**

Interior and exterior signage, lighting, armatures, etc. must be modest in design and appropriate to the character of the site. Care must be taken to not damage the historic masonry when affixing these features. If components are attached, drilling into mortar joints, which can be repaired, is permitted; drilling directly into masonry, which cannot be repaired, is strictly prohibited. Please forward methods of attachment for our review *prior* to installing signs and other fixtures. Photographs of sensitively anchored signs and fixtures must also be submitted with the *Request for Certification of Completed Work/Part 3*.

Please note Detail 3/A5.60 shows an attachment method that illustrates drilling directly into historic masonry (drill a "...1" diameter hole in stone."); this treatment is *not* permitted. This is of concern throughout the property, but especially at primary elevations and around distinctive architectural elements. Revised attachment details for this area must be submitted for our review prior to installing signs or fixtures.

15) **Interior Woodwork (Trim; Wainscoting, etc.)**

a) **Wood Wainscoting:**

Please revise language in the application to reflect the new strategy for treating historic wood wainscoting below windows and elsewhere in the building. As demonstrated by onsite repairs, the wood paneling found on all floors is in excellent condition and can easily be removed and repaired. As a result, as much as possible of this important feature should be preserved. (Treatment Card 79)

b) Beadboard Finish:

Treatments Cards 71 and 86 state that when the double-loaded corridors are restored, beadboard will be covered with a "new finish material." Please clarify what this entails to ensure the compatibility of this action.

c) New Wall Treatments and Beadboard Wainscoting:

It is unclear from the information provided whether the proposed wall treatments for corridors are for new walls or are intended for historic walls as well, including walls which retain historic beadboard wainscoting. To make certain these treatments meet the Secretary's Standards, clarification is required. (A2.03, A9.52d, Treatment Cards 71 and 86)

d) Baseboards:

Treatment Cards 72 and 88 state that baseboards will be replaced with wood and "medium-density fiberboard." Removing the majority of baseboards in this project was approved, but it was our understanding they would be replaced with like materials. Fiberboard is a substitute material that may not have the same visual quality or durability of wood. Please clarify.

e) Tile in Turrets:

Historic tile remains in many of the upper-floor turrets. We recommend that this unique finish be retained, repaired and incorporated into the new uses(s) for the turrets.

16) Railings:

a) Areaway Railings:

Are any code modifications required for the open railings at the areaways surrounding the building? (Treatment Card 28)

Was a waiver granted for the non-historic railings at the 11th and 12th Street areaways? (Treatment Card 31) If these railings require replacement or modification, please submit this design to ensure its compatibility.

How will the revisions to railings at the 11th Street non-historic scissor lift (to be removed) appear? (Treatment Card 31)

b) Interior Railings:

i) Brass Cortile Railings:

Details No. 3 and No. 4 on drawings AH4.16 and Treatment Cards 127 and 128, suggest that brass cortile railings will be modified in a manner inconsistent with the Secretary's Standards. We understand, however, that these changes are no longer required because a determination was made that these railings may remain unaltered. Please confirm this is the case.

17) Guest Rooms:

a) New Features:

Additional information is required on several treatments proposed for the guest room. Many of these details may be temporary and limited to new walls - for example the "simulated windows" - but clarification is required to make certain these changes meet the Secretary's Standards. We must also confirm that all ceilings treatments are appropriate.

b) Ceilings Medallions/Added Trim at Ceilings:

Drawings submitted with this application indicate that guest room and guest suite ceilings continue to include decorative medallions at their centers. It also appears additional trim is added to highlight these medallions. As discussed over the course of this project, including highly-elaborate features such as these medallions (and additional embellishment) is out of character with this former post office. Further consultation on this issue is required so that final treatments for guest rooms and guest suites meet the Secretary's Standards.

18) Security Cage at Stair Landing:

A design for the security cage proposed for the east side stairway must be submitted for review and approval to the National Park Service, through the District Historic Preservation Office, *prior* to installation. (Treatment Card 79)

19) Bird-Proofing System:

More information is required on the type of bird-proofing system to be used on the building. Where will it be located, how will it appear, and what methods will be used for its attachment? Its installation must not alter the character of the exterior or destroy historic architectural fabric. (Treatment Card 26)

20) Clock Tower Museum:

Please forward plans for the new NPS clock tower museum when these become available.

21) New Systems/New Equipment:

New systems must be sensitively located without adversely impacting the interior of the building. Ductwork must be concealed (no exposed ductwork in this historically-finished interior); must not drop below window heads or intersect windows; must be installed close to the ceiling; and must not subdivide primary spaces. Drawings of new systems must be submitted for review and approval to the National Park Service, through the State Historic Preservation Office, *prior* to installation (or ordering components).

Please note mechanical equipment or any new features added to the roof must not be more visible than the components already in place. To demonstrate the prominence of anything added to the roof, physical mock-ups must be constructed. These mock-ups should then be photographed from around the site (from both near and far). The results of this exercise should be forwarded to the National Park Service, through the DC Historic Preservation Office, *prior* to installing any roof features. (Treatment Cards 98 and 101)

New "air distribution" grills will replace bulletin boards in upper-floor elevator lobbies. Please submit designs for these new features to ensure they are appropriate to the character of the interior. (Treatment Card 81)

22) Cortile Mezzanine:

To reiterate the Part 2 narrative, the finalized design of the new cortile mezzanine will be submitted for review and approval (in amendment form) *prior* to construction. (Treatment Card 109)

23) Former Registrar's Room:

Treatment Card 139 states that the "Registrar's Room" will be converted into a "Library" and that the "high openings" at the rear wall of this space will be enclosed. Please clarify. Why is this necessary and will any historic fabric be affected by this action?

24) Storefront at Former Scissor Lift:

What is the design of the proposed storefront at the non-historic scissor lift - 11th Street areaaway? (Treatment Card 151)

25) Cortile Skylight Structure and Artwork:

It is our understanding that all superfluous steel framing added to the skeleton of the lower skylight will be removed. Treatment Card 110 does not mention this action. Please clarify. (S-103)

The information on Treatment Card 148 as to whether the large piece of fabric artwork will be reinstated in the Cortile is vague. It is our understanding that this sculpture will be put back in place. Please confirm.

26) Vaults:

In select guest rooms (or other areas of the building?), where historic vaults will be incorporated into guest rooms, please retain the historic doors in place. They may be propped open and secured, but the doors of these unique features should not be removed. Could the vaults be reused for guests who desire to secure valuables? (Treatment Card 160)

The National Park Service has determined that this project will meet the Secretary of the Interior Standards for Rehabilitation if the condition(s) listed in the box above are met.

6/26/14

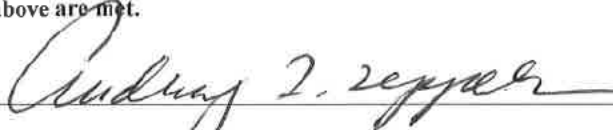

NPS-TPS 202-354-2027

Date

National Park Service Signature
Audrey T. Tepper

Telephone Number

RE_ Attached Image.pdf

From: [David Orowitz](#)
To: [Tepper, Audrey](#)
Cc: [Hany Hassan](#); [John Cullinane](#); [Nancy Witherell](#); [Andrew Lewis](#); [Brian Goeken](#)
Subject: RE: Attached Image
Date: Thursday, June 26, 2014 4:11:46 PM

Thank you, Audrey. We will review and get back to you quickly on next steps.

Best,
Dave

David Orowitz
Senior Vice President, Acquisitions and Development
The Trump Organization
725 Fifth Avenue | New York, NY | 10022
p. 212.836.3252 | m. 646.315.4698 | f. 212.836.3202
dorowitz@trumporg.com | trump.com

From: Tepper, Audrey [mailto:audrey_tepper@nps.gov]
Sent: Thursday, June 26, 2014 5:55 PM
To: David Orowitz
Cc: Hany Hassan; John Cullinane; Nancy Witherell; Andrew Lewis; Brian Goeken
Subject: Fwd: Attached Image

David:

Attached is a scanned copy of the Part 2 conditional approval for the Old Post Office in Washington, DC (NPS Project No. 30491)...the original will follow in the mail. Although this document is lengthy, the majority of what is requested is clarification where we found gaps in the submitted information. Feel free to get in touch should you have questions.

Thank you very much for working with the National Park Service to bring this exciting project to fruition. We look forward to more continued collaboration.

Sincerely,

Audrey Tepper

----- Forwarded message -----

From: <CR_Scans@nps.gov>
Date: 2014-06-26 17:46 GMT-04:00
Subject: Attached Image
To: Audrey <audrey_tepper@nps.gov>

--
Audrey T. Tepper - LEED Green Associate
Historical Architect
National Park Service

Technical Preservation Services Branch
1201 Eye Street, NW - Org. 2200
Washington, DC 20005
202-354-2027
202-371-1616 (FAX)

audrey_tepper@nps.gov

This e-mail message, and any attachments to it, are for the sole use of the intended recipients, and may contain confidential and privileged information. Any unauthorized review, use, disclosure or distribution of this email message or its attachments is prohibited. If you are not the intended recipient, please contact the sender by reply email and destroy all copies of the original message. Please note that any views or opinions presented in this email are solely those of the author and do not necessarily represent those of the company. Finally, while the company uses virus protection, the recipient should check this email and any attachments for the presence of viruses. The company accepts no liability for any damage caused by any virus transmitted by this email.

Re_ Attached Image_1.pdf

From: [Tepper, Audrey](#)
To: [David Orowitz](#)
Subject: Re: Attached Image
Date: Friday, June 27, 2014 4:53:17 AM

Here to assist!

Audrey

On Thu, Jun 26, 2014 at 6:12 PM, David Orowitz <dorowitz@trumporg.com> wrote:

Thank you, Audrey. We will review and get back to you quickly on next steps.

Best,

Dave

David Orowitz
Senior Vice President, Acquisitions and Development

The Trump Organization

725 Fifth Avenue | New York, NY | 10022
p. 212.836.3252 | m. 646.315.4698 | f. 212.836.3202

dorowitz@trumporg.com | trump.com

From: Tepper, Audrey [mailto:audrey_tepper@nps.gov]
Sent: Thursday, June 26, 2014 5:55 PM
To: David Orowitz
Cc: Hany Hassan; John Cullinane; Nancy Witherell; Andrew Lewis; Brian Goeken
Subject: Fwd: Attached Image

David:

Attached is a scanned copy of the Part 2 conditional approval for the Old Post Office in Washington, DC (NPS Project No. 30491)...the original will follow in the mail. Although this document is lengthy, the majority of what is requested is clarification where we found gaps in the submitted information. Feel free to get in touch should you have questions.

Thank you very much for working with the National Park Service to bring this exciting

project to fruition. We look forward to more continued collaboration.

Sincerely,

Audrey Tepper

----- Forwarded message -----
From: <CR_Scans@nps.gov>
Date: 2014-06-26 17:46 GMT-04:00
Subject: Attached Image
To: Audrey <audrey_tepper@nps.gov>

--

Audrey T. Tepper - LEED Green Associate

Historical Architect

National Park Service

Technical Preservation Services Branch

1201 Eye Street, NW - Org. 2200

Washington, DC 20005

202-354-2027

202-371-1616 (FAX)

audrey_tepper@nps.gov

This e-mail message, and any attachments to it, are for the sole use of the intended recipients, and may contain confidential and privileged information. Any unauthorized review, use, disclosure or distribution of this email message or its attachments is prohibited. If you are not the intended recipient, please contact the sender by reply email and destroy all copies of the original message. Please note that any views or opinions presented in this email are solely those of the author and do not necessarily represent those of the company. Finally, while the company uses virus protection, the recipient should check this email and any attachments for the presence of viruses. The company accepts no liability for any damage caused by any virus transmitted by this email.

--

Audrey T. Tepper - LEED Green Associate
Historical Architect
National Park Service
Technical Preservation Services Branch
1201 Eye Street, NW - Org. 2200
Washington, DC 20005
202-354-2027
202-371-1616 (FAX)
audrey_tepper@nps.gov

Re_ Attached Image(1).pdf

From: [Tepper, Audrey](#)
To: [John Cullinane](#); [Hany Hassan](#); [David Orowitz](#); [Nancy Witherell](#)
Cc: [Andrew Lewis](#)
Subject: Re: Attached Image
Date: Friday, June 27, 2014 4:58:51 AM

John:

Even if it's not stated, it is *always* best to get approval for treatments *prior* to construction....we hate surprises!

I am out of the office the remainder of today, but will be around after that. If you have questions, I'm sure we can find a time to chat collectively.

Audrey

On Thu, Jun 26, 2014 at 6:30 PM, John Cullinane <jcullinane@jcaaia.com> wrote:
Not bad. When would you like to discuss and sort out? A few require approval prior to construction start, but most do not.

John

John J. Cullinane, AIA
President
John Cullinane Architect, LLC

410.903.0256
jcullinane@jcaaia.com

On Jun 26, 2014, at 6:12 PM, David Orowitz wrote:

Thank you, Audrey. We will review and get back to you quickly on next steps.

Best,
Dave

David Orowitz
Senior Vice President, Acquisitions and Development
The Trump Organization
725 Fifth Avenue | New York, NY | 10022
p. 212.836.3252 | m. 646.315.4698 | f. 212.836.3202
dorowitz@trumporg.com | trump.com

From: Tepper, Audrey [mailto:audrey_tepper@nps.gov]
Sent: Thursday, June 26, 2014 5:55 PM

To: David Orowitz
Cc: Hany Hassan; John Cullinane; Nancy Witherell; Andrew Lewis; Brian Goeken
Subject: Fwd: Attached Image

David:

Attached is a scanned copy of the Part 2 conditional approval for the Old Post Office in Washington, DC (NPS Project No. 30491)...the original will follow in the mail. Although this document is lengthy, the majority of what is requested is clarification where we found gaps in the submitted information. Feel free to get in touch should you have questions.

Thank you very much for working with the National Park Service to bring this exciting project to fruition. We look forward to more continued collaboration.

Sincerely,

Audrey Tepper

----- Forwarded message -----
From: <CR_Scans@nps.gov>
Date: 2014-06-26 17:46 GMT-04:00
Subject: Attached Image
To: Audrey <audrey_tepper@nps.gov>

--

Audrey T. Tepper - LEED Green Associate
Historical Architect
National Park Service
Technical Preservation Services Branch
1201 Eye Street, NW - Org. 2200
Washington, DC 20005
202-354-2027
202-371-1616 (FAX)
audrey_tepper@nps.gov

This e-mail message, and any attachments to it, are for the sole use of the intended recipients, and may contain confidential and privileged information. Any unauthorized review, use, disclosure or distribution of this email message or its attachments is prohibited. If you are not the intended recipient, please contact the sender by reply email and destroy all copies of the original message. Please note that any views or opinions presented in this email are solely those of the author and do not necessarily represent those of the company. Finally, while the company uses virus protection, the recipient should check this email and any attachments for the presence of viruses. The company accepts no liability for any damage caused by any virus transmitted by this email.

--

Audrey T. Tepper - LEED Green Associate
Historical Architect
National Park Service
Technical Preservation Services Branch
1201 Eye Street, NW - Org. 2200
Washington, DC 20005
202-354-2027
202-371-1616 (FAX)
audrey_tepper@nps.gov

Follow-up to Call.pdf

From: [David Orowitz](#)
To: brian_woodbury@nps.gov
Cc: "[Brett Banks](#)"
Subject: Follow-up to Call
Date: Thursday, July 03, 2014 11:02:58 AM
Attachments: [OPO Sidewalk Bridge Drawing 1.pdf](#)
[OPO Sidewalk Bridge Drawing 2.pdf](#)

Brian,

It was good speaking to you earlier and thank you for your focus on getting this permit finalized. As requested, here is a bit more context on the work that we need to do as well as the timeline. NPS had asked that we combine two pieces of work under this single permit.

- 1) Sidewalk bridge – attached are shop drawings of the sidewalk bridge. These were developed by the fabricator (they show more detail than what is included in a permit application). We are planning to have a ground breaking event with the Mayor, Congresswoman Norton, and other members of the City Council and Congress on July 23rd. In order to be sure that the bridge is up in time for this event, we need to have the permit no later than July 8th.
- 2) Curb cut – as you mentioned, the curb cut has already been approved as part of the transfer of jurisdiction. Since the work will peripherally impact portions of NPS jurisdiction as originally designed, we need the permit to allow for the work.

I hope this context is helpful. If any additional information is required, please let me know. Thanks again for doing whatever you can to get this finalized by first thing next week.

Best,
Dave

David Orowitz
Senior Vice President, Acquisitions and Development
The Trump Organization
725 Fifth Avenue | New York, NY | 10022
p. 212.836.3252 | m. 646.315.4698 | f. 212.836.3202
dorowitz@trumporg.com | trump.com

This e-mail message, and any attachments to it, are for the sole use of the intended recipients, and may contain confidential and privileged information. Any unauthorized review, use, disclosure or distribution of this email message or its attachments is prohibited. If you are not the intended recipient, please contact the sender by reply email and destroy all copies of the original message. Please note that any views or opinions presented in this email are solely those of the author and do not necessarily represent those of the company. Finally, while the company uses virus protection, the recipient should check this email and any attachments for the presence of viruses. The company accepts no liability for any damage caused by any virus transmitted by this email.

OPO Sidewalk Bridge Drawing 1.pdf



Patuxent Engineering Group, L.L.C.

5741 MAIN STREET
ELKBRIDGE, MARYLAND 21075
PHONE: (410) 796-8130
FAX: (410) 796-8131

OLD POST OFFICE
WASHINGTON, DC

PROTECTION NOTES

- LOADING
 - DECK DEAD LOAD IS FROM SELF-WEIGHT OF MATERIALS
 - DECK LIVE LOAD = 200 psf
 - MAXIMUM WIND PRESSURE = 36.49 psf FOR WALL, 26.5 psf FOR PARAPET
 - WIND SPEED = 90 mph
 - VELOCITY REDUCTION FACTOR = 0.8 IN ACCORDANCE WITH ASCE 37-02
 - IMPORTANCE FACTOR = 1.0
 - WALL IS TREATED AS SOLID SIGN & PARAPET IS TREATED AS PARAPET EXPOSURE CATEGORY C
 - DESIGNED IN ACCORDANCE WITH ASCE 7-05
 - MAXIMUM SHED LEG LOAD = 11.1 K FOR DEAD AND LIVE LOADING
 - MAXIMUM BRACE LOAD = 6.3 K
 - MAXIMUM CABLE TENSION = 3.42 K
- CONSTRUCTION
 - ALL SHED LEGS AND COMPONENTS TO BE INSTALLED PER MANUFACTURER'S SPECIFICATIONS
 - ALL SYSTEM COMPONENTS TO BE INSTALLED PER MANUFACTURER'S SPECIFICATIONS
 - ALL PIPE BRACES TO BE INSTALLED PER MANUFACTURER'S SPECIFICATIONS
 - ALL SYSTEM COMPONENTS TO BE COMPATIBLE TO ENSURE PROPER FIT
 - ALL SYSTEM COMPONENTS AND SHED LEGS TO BE INSTALLED PLUMB AND LEVEL
 - ALL BEAMS TO BE INSTALLED FLAT AND LEVEL UON
 - ALL ALUMINUM BEAMS CONNECTED TO HEADER BEAMS ARE TO BE ATTACHED USING A MINIMUM OF (2) C-CLAMPS CATTY CORNER PER INTERSECTION OR (2) A-CLIPS PER INTERSECTION
 - ALL HEADER BEAMS ARE TO BE ATTACHED TO SHED LEGS USING (2) HEADCLIPS PER INTERSECTION
 - FASTEN PLYWOOD TO 2x10 PLANKS USING 8d COMMON WIRE NAILS @ 12" O.C. EACH WAY
 - FASTEN 2x10 TO NAILER USING (2) 16d COMMON WIRE NAILS PER INTERSECTION
 - ALL WOOD CONNECTORS ARE TO BE INSTALLED PER MANUFACTURER'S SPECIFICATIONS
 - ALL ANCHORS ARE TO BE INSTALLED PER MANUFACTURER'S SPECIFICATIONS
 - ALL FASTENERS TO BE GALVANIZED
 - PLYWOOD IS TO RUN IN STRONG DIRECTION OVER SUPPORTS
 - ALL CABLES AND RIGGING EQUIPMENT ARE TO BE INSTALLED PER MANUFACTURER'S SPECIFICATIONS
- MATERIALS
 - ALL ALUMINUM TO BE 6061-T6
 - ALL STEEL PIPE TO BE A53, GRADE B, Fy = 35 ksi
 - ALL STEEL PLATE TO BE A36, Fy = 36 ksi
 - ALL STEEL BEAMS TO BE A992, Fy = 50 ksi
 - ALL THREADED RODS TO BE GRADE 5 UON
 - ALL BOLTS TO BE A325
 - ALL WOOD TO BE SPF #2 OR BETTER
 - Fb MIN = 875 psi
 - Fc PER. = 425 psi
 - ALL VERTICAL STRUCTURE TO BE GALVANIZED STEEL, Fy = 50 ksi
- MISCELLANEOUS
 - SHED STRUCTURE IS NOT INTENDED FOR ACCESS, RIGGING, OR STORAGE
 - DIMENSIONS AND LOGISTICAL COORDINATION TO BE CONFIRMED IN THE FIELD BY OTHERS
 - VERIFICATION OF EXISTING STRUCTURE BY OTHERS
 - ALL SIGNS TO BE AS PER CODE
 - ALL LIGHTING AS REQUIRED TO BE BY OTHERS

POST-INSTALLED ANCHORS

- EXCEPT WHERE INDICATED ON THE DRAWINGS, POST-INSTALLED ANCHORS SHALL CONSIST OF THE FOLLOWING ANCHOR TYPES AS PROVIDED BY HILTI, INC. CONTACT HILTI AT (800) 879-8000 FOR PRODUCT RELATED QUESTIONS.
 - ANCHORAGE TO CONCRETE
 - ADHESIVE ANCHORS FOR CRACKED AND UNCRACKED CONCRETE USE:
 - HILTI HIT-HY 200 SAFE SET SYSTEM WITH HILTI HIT-Z ROD PER ICC ESR-3187
 - HILTI HIT-HY 200 SAFE SET SYSTEM WITH HILTI HOLLOW DRILL BIT SYSTEM WITH HAS-E THREADED ROD PER ICC ESR-3187
 - ANCHOR CAPACITY USED IN DESIGN SHALL BE BASED ON THE TECHNICAL DATA PUBLISHED BY HILTI OR SUCH OTHER METHOD AS APPROVED BY THE STRUCTURAL ENGINEER OF RECORD. SUBSTITUTION REQUESTS FOR ALTERNATE PRODUCTS MUST BE APPROVED IN WRITING BY THE STRUCTURAL ENGINEER OF RECORD PRIOR TO USE. CONTRACTOR SHALL PROVIDE CALCULATIONS DEMONSTRATING THAT THE SUBSTITUTED PRODUCT IS CAPABLE OF ACHIEVING THE PERFORMANCE VALUES OF THE SPECIFIED PRODUCT. SUBSTITUTIONS WILL BE EVALUATED BY THEIR HAVING AN ICC ESR SHOWING COMPLIANCE WITH THE RELEVANT BUILDING CODE FOR SEISMIC USES, LOAD RESISTANCE, INSTALLATION CATEGORY, AND AVAILABILITY OF COMPREHENSIVE INSTALLATION INSTRUCTIONS. ADHESIVE ANCHOR EVALUATION WILL ALSO CONSIDER CREEP, IN-SERVICE TEMPERATURE AND INSTALLATION TEMPERATURE.
 - INSTALL ANCHORS PER THE MANUFACTURER INSTRUCTIONS, AS INCLUDED IN THE ANCHOR PACKAGING.
 - THE CONTRACTOR SHALL ARRANGE AN ANCHOR MANUFACTURER'S REPRESENTATIVE TO PROVIDE ONSITE INSTALLATION TRAINING FOR ALL OF THEIR ANCHORING PRODUCTS SPECIFIED. THE STRUCTURAL ENGINEER OF RECORD MUST RECEIVE DOCUMENTED CONFIRMATION THAT ALL OF THE CONTRACTOR'S PERSONNEL WHO INSTALL ANCHORS ARE TRAINED PRIOR TO THE COMMENCEMENT OF INSTALLING ANCHORS.
 - ANCHOR CAPACITY IS DEPENDENT UPON SPACING BETWEEN ADJACENT ANCHORS AND PROXIMITY OF ANCHORS TO EDGE OF CONCRETE. INSTALL ANCHORS IN ACCORDANCE WITH SPACING AND EDGE CLEARANCES INDICATED ON THE DRAWINGS.
 - EXISTING REINFORCING BARS IN THE CONCRETE STRUCTURE MAY CONFLICT WITH SPECIFIC ANCHOR LOCATIONS. UNLESS NOTED ON THE DRAWINGS THAT THE BARS CAN BE CUT, THE CONTRACTOR SHALL REVIEW THE EXISTING STRUCTURAL DRAWINGS AND SHALL UNDERTAKE TO LOCATE THE POSITION OF THE REINFORCING BARS AT THE LOCATIONS OF THE CONCRETE ANCHORS, BY HILTI FERROSCAN, GPR, X-RAY, CHIPPING OR OTHER MEANS.

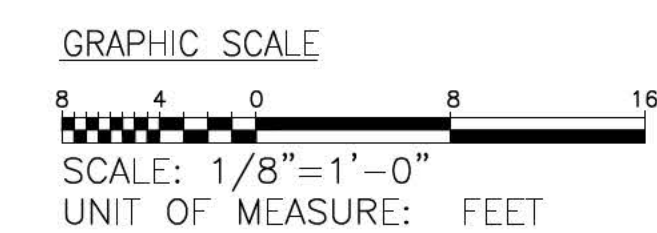
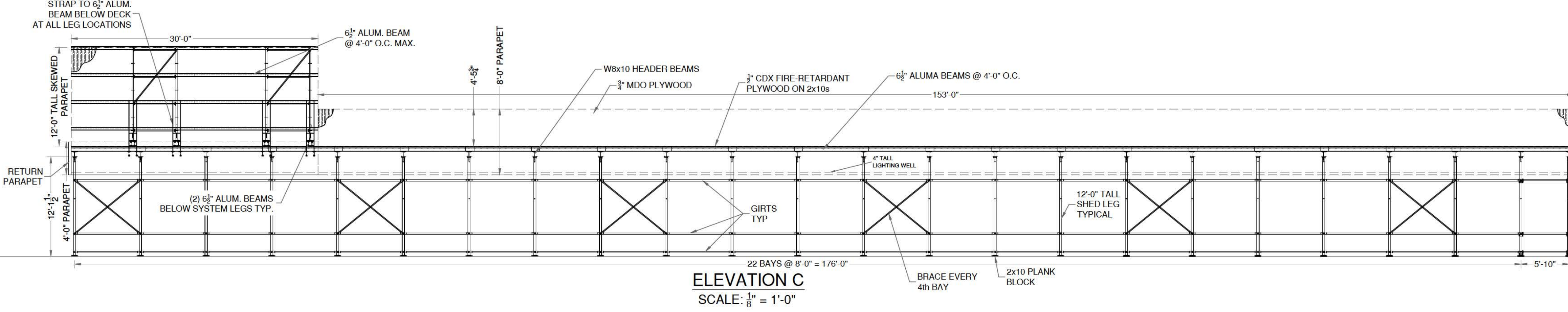
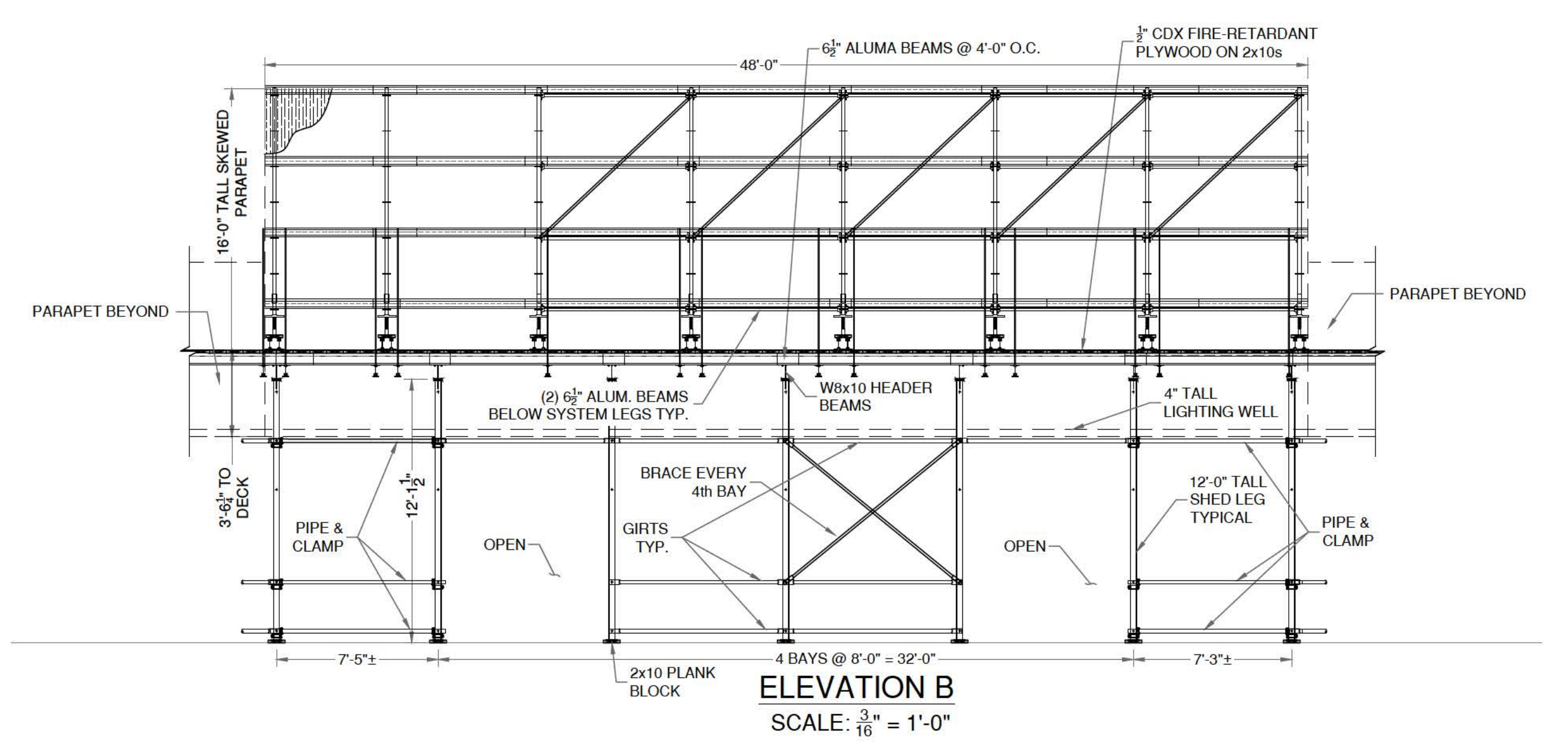
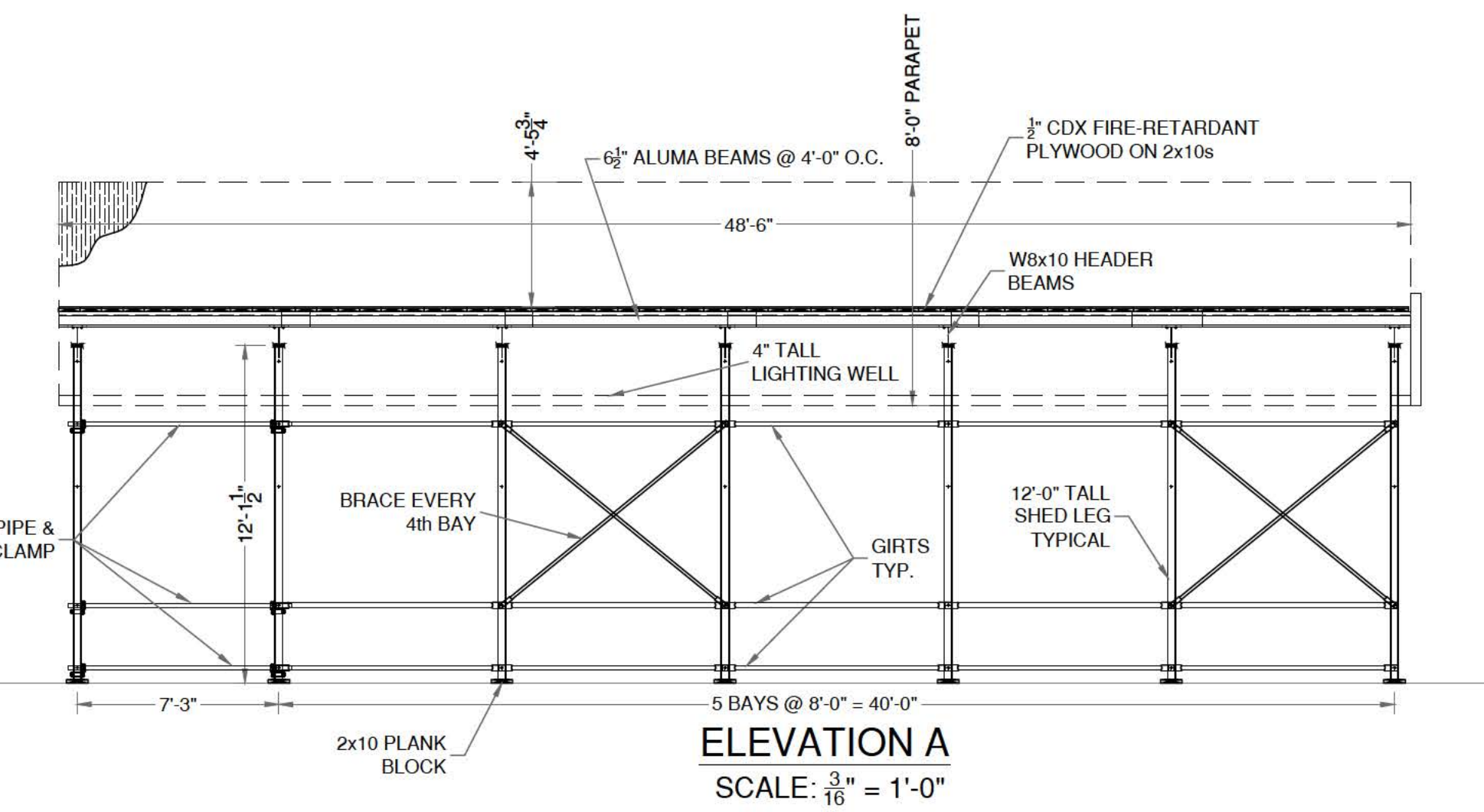
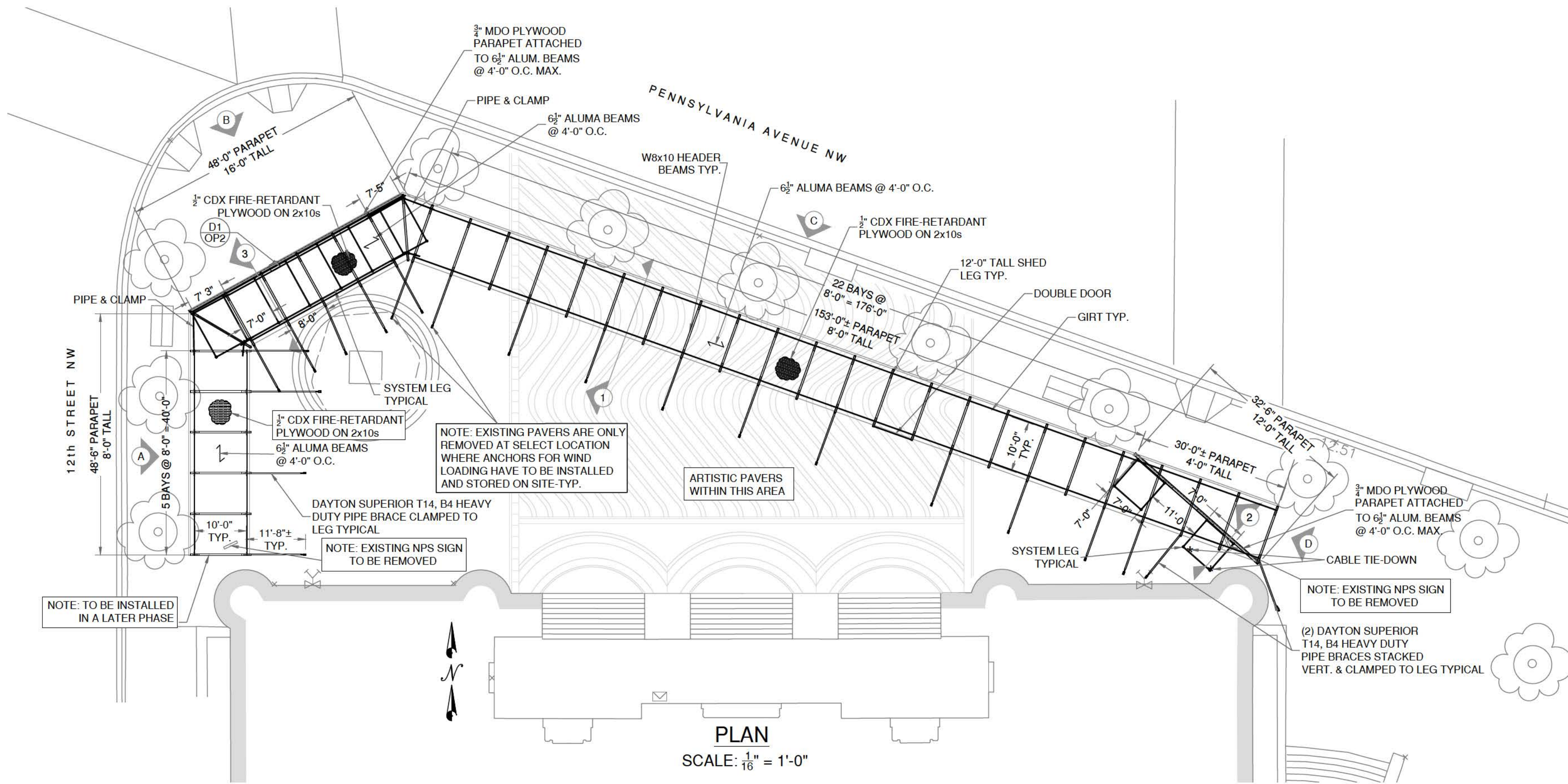

Proprietary Note
This Drawing was produced exclusively for Scaffold Resource LLC any use or reproduction without written permission is prohibited"

REV. NO.	DATE	BY	DESCRIPTION

CONTRACTOR:
Scaffold Resource
9513 LANHAM SEVERN ROAD
LANHAM, MD 20706
PHONE: 301 459-2650
FAX: 301 459-2653

DRAWN BY: MM CHECKED BY: JOC

DATE: 6/9/14

SUBJECT: OVERHEAD PROTECTION

PROJECT: OLD POST OFFICE

14-234-OP1

SHEET 1 OF 2

OPO Sidewalk Bridge Drawing 2.pdf

Entrance.pdf

From: [David Orowitz](#)
To: [Andrew Lewis](#); [Audrey T. Tepper](#)
Cc: [Hany Hassan](#)
Subject: Entrance
Date: Tuesday, July 08, 2014 11:19:28 AM

Andy and Audrey,

Look forward to seeing you at 2.

We left your names with the guard who will bring you up. Please enter at C St (south side of the building).

Dave

David Orowitz
SVP, Acquisitions and Development
The Trump Organization
725 5th Avenue
New York, New York 10022
o: 212-836-3252 m: 646-315-4698
dorowitz@trumporg.com

This e-mail message, and any attachments to it, are for the sole use of the intended recipients, and may contain confidential and privileged information. Any unauthorized review, use, disclosure or distribution of this email message or its attachments is prohibited. If you are not the intended recipient, please contact the sender by reply email and destroy all copies of the original message. Please note that any views or opinions presented in this email are solely those of the author and do not necessarily represent those of the company. Finally, while the company uses virus protection, the recipient should check this email and any attachments for the presence of viruses. The company accepts no liability for any damage caused by any virus transmitted by this email.

Re_Entrance.pdf

From: [Tepper, Audrey](#)
To: [David Orowitz](#)
Subject: Re: Entrance
Date: Tuesday, July 08, 2014 11:20:45 AM

I'll be there shortly!

On Tue, Jul 8, 2014 at 1:19 PM, David Orowitz <dorowitz@trumporg.com> wrote:
Andy and Audrey,

Look forward to seeing you at 2.

We left your names with the guard who will bring you up. Please enter at C St (south side of the building).

Dave

David Orowitz
SVP, Acquisitions and Development
The Trump Organization
725 5th Avenue
New York, New York 10022
o: 212-836-3252 m: 646-315-4698
dorowitz@trumporg.com

This e-mail message, and any attachments to it, are for the sole use of the intended recipients, and may contain confidential and privileged information. Any unauthorized review, use, disclosure or distribution of this email message or its attachments is prohibited. If you are not the intended recipient, please contact the sender by reply email and destroy all copies of the original message. Please note that any views or opinions presented in this email are solely those of the author and do not necessarily represent those of the company. Finally, while the company uses virus protection, the recipient should check this email and any attachments for the presence of viruses. The company accepts no liability for any damage caused by any virus transmitted by this email.

--

Audrey T. Tepper - LEED Green Associate
Historical Architect
National Park Service
Technical Preservation Services Branch
1201 Eye Street, NW - Org. 2200
Washington, DC 20005
202-354-2027
202-371-1616 (FAX)
audrey_tepper@nps.gov

Re_ OPO review.pdf

From: [Tepper, Audrey](#)
To: [Hany Hassan](#)
Cc: [Andrew \(OP\) Lewis](#); [David Orowitz](#)
Subject: Re: OPO review
Date: Thursday, July 10, 2014 5:56:01 AM

Hany,

Thanks, also, for your time. Andy...pictures are forthcoming.

Audrey

On Wed, Jul 9, 2014 at 9:42 PM, Hany Hassan <hhassan@bbbarch.com> wrote:

Audrey, Andy:

Thanks so much for making the time yesterday. I thought it was a very productive. Andy, I am sorry you missed the model rooms review, totally understandable! Audrey took a lot of pictures to share with you, please let us know if you would like to see it in person.

Best,

Hany

Hany Hassan FAIA
Partner

Beyer Blinder Belle
Architects & Planners LLP
3307 M Street, NW, Suite 301
Washington, DC 20007
[202-333-8000](tel:202-333-8000)
[202 333 8843](tel:202-333-8843) fax
hhassan@bbbarch.com
www.beyerblinderbelle.com

The above e-mail is for the intended recipient only, and may contain information that is privileged, confidential, or otherwise protected from disclosure. If you are not the intended recipient, please advise the sender immediately. Nothing in this e-mail or any attachments to this e-mail grants any license or transfers any ownership to the contents of the e-mail or attachments or any intellectual property rights contained therein. Unauthorized use or distribution is prohibited and may be unlawful. Beyer Blinder Belle Architects Planners LLP accepts no responsibility for any loss or damage from the use of this message and/or any attachments including damage from viruses.

--

Audrey T. Tepper - LEED Green Associate
Historical Architect
National Park Service

Technical Preservation Services Branch
1201 Eye Street, NW - Org. 2200
Washington, DC 20005
202-354-2027
202-371-1616 (FAX)
audrey_tepper@nps.gov

Re_ Follow-up to Call.pdf

From: [Woodbury, Brian](#)
To: [David Orowitz](#)
Subject: Re: Follow-up to Call
Date: Friday, July 11, 2014 7:37:52 AM

Hi David,

I hope you are well. I don't have confirmation that the permit has been signed yet but it is close. Georgeann Smale from my office dogged this pretty hard to obtain solicitor review and to get the park personnel on board. I would be grateful if you could just send her a quick note recognizing her efforts.

Kind regards,

Brian

On Thu, Jul 3, 2014 at 1:03 PM, David Orowitz <dorowitz@trumporg.com> wrote:

Brian,

It was good speaking to you earlier and thank you for your focus on getting this permit finalized. As requested, here is a bit more context on the work that we need to do as well as the timeline. NPS had asked that we combine two pieces of work under this single permit.

1) Sidewalk bridge – attached are shop drawings of the sidewalk bridge. These were developed by the fabricator (they show more detail than what is included in a permit application). We are planning to have a ground breaking event with the Mayor, Congresswoman Norton, and other members of the City Council and Congress on July 23rd. In order to be sure that the bridge is up in time for this event, we need to have the permit no later than July 8th.

2) Curb cut – as you mentioned, the curb cut has already been approved as part of the transfer of jurisdiction. Since the work will peripherally impact portions of NPS jurisdiction as originally designed, we need the permit to allow for the work.

I hope this context is helpful. If any additional information is required, please let me know. Thanks again for doing whatever you can to get this finalized by first thing next week.

Best,

Dave

David Orowitz

Senior Vice President, Acquisitions and Development

The Trump Organization

725 Fifth Avenue | New York, NY | 10022
p. 212.836.3252 | m. 646.315.4698 | f. 212.836.3202

dorowitz@trumporg.com | trump.com

This e-mail message, and any attachments to it, are for the sole use of the intended recipients, and may contain confidential and privileged information. Any unauthorized review, use, disclosure or distribution of this email message or its attachments is prohibited. If you are not the intended recipient, please contact the sender by reply email and destroy all copies of the original message. Please note that any views or opinions presented in this email are solely those of the author and do not necessarily represent those of the company. Finally, while the company uses virus protection, the recipient should check this email and any attachments for the presence of viruses. The company accepts no liability for any damage caused by any virus transmitted by this email.

--

Brian M. Woodbury
Chief of Lands
National Park Service - National Capital Region
1100 Ohio Drive, SW
Washington, DC 20242
(202) 619.7034
brian_woodbury@nps.gov

RE_ Follow-up to Call_1.pdf

From: [David Orowitz](#)
To: [Woodbury, Brian](#)
Subject: RE: Follow-up to Call
Date: Friday, July 11, 2014 8:41:01 AM

Brian,

Hope you are well also. Unfortunately, the permit that was sent yesterday did not address the only comment that we (Trump) had. The language was actually made even more restrictive about including basic sidewalk bridge signage (Item #29). This leaves us in a hard place as we need to have the permit signed today in order to have the sidewalk bridge up for our VIP event on the 23rd.

I know that some conversations are taking place on this, but anything you can do to address this as well would be greatly appreciated. Though it is not ideal, we could live with the idea that we need to come back to approve any signage. We just do not want the permit to say that it is forbidden.

Dave

David Orowitz
Senior Vice President, Acquisitions and Development
The Trump Organization
725 Fifth Avenue | New York, NY | 10022
p. 212.836.3252 | m. 646.315.4698 | f. 212.836.3202
dorowitz@trumporg.com | trump.com

From: Woodbury, Brian [mailto:brian_woodbury@nps.gov]
Sent: Friday, July 11, 2014 9:38 AM
To: David Orowitz
Subject: Re: Follow-up to Call

Hi David,

I hope you are well. I don't have confirmation that the permit has been signed yet but it is close. Georgeann Smale from my office dogged this pretty hard to obtain solicitor review and to get the park personnel on board. I would be grateful if you could just send her a quick note recognizing her efforts.

Kind regards,

Brian

On Thu, Jul 3, 2014 at 1:03 PM, David Orowitz <dorowitz@trumporg.com> wrote:
Brian,

It was good speaking to you earlier and thank you for your focus on getting this permit finalized. As requested, here is a bit more context on the work that we need to do as well as the timeline. NPS had asked that we combine two pieces of work under this single permit.

1) Sidewalk bridge – attached are shop drawings of the sidewalk bridge. These were developed by the fabricator (they show more detail than what is included in a permit

application). We are planning to have a ground breaking event with the Mayor, Congresswoman Norton, and other members of the City Council and Congress on July 23rd. In order to be sure that the bridge is up in time for this event, we need to have the permit no later than July 8th.

2) Curb cut – as you mentioned, the curb cut has already been approved as part of the transfer of jurisdiction. Since the work will peripherally impact portions of NPS jurisdiction as originally designed, we need the permit to allow for the work.

I hope this context is helpful. If any additional information is required, please let me know. Thanks again for doing whatever you can to get this finalized by first thing next week.

Best,
Dave

David Orowitz
Senior Vice President, Acquisitions and Development
The Trump Organization
725 Fifth Avenue | New York, NY | 10022
p. 212.836.3252 | m. 646.315.4698 | f. 212.836.3202
dorowitz@trumporg.com | trump.com

This e-mail message, and any attachments to it, are for the sole use of the intended recipients, and may contain confidential and privileged information. Any unauthorized review, use, disclosure or distribution of this email message or its attachments is prohibited. If you are not the intended recipient, please contact the sender by reply email and destroy all copies of the original message. Please note that any views or opinions presented in this email are solely those of the author and do not necessarily represent those of the company. Finally, while the company uses virus protection, the recipient should check this email and any attachments for the presence of viruses. The company accepts no liability for any damage caused by any virus transmitted by this email.

--

Brian M. Woodbury
Chief of Lands
National Park Service - National Capital Region
1100 Ohio Drive, SW
Washington, DC 20242
(202) 619.7034
brian_woodbury@nps.gov

Re_ Follow-up to Call(1).pdf

From: [Woodbury, Brian](#)
To: [David Orowitz](#)
Subject: Re: Follow-up to Call
Date: Friday, July 11, 2014 8:49:15 AM

David, I understand. Let me see what I can do.

-Brian

On Fri, Jul 11, 2014 at 10:42 AM, David Orowitz <dorowitz@trumporg.com> wrote:

Brian,

Hope you are well also. Unfortunately, the permit that was sent yesterday did not address the only comment that we (Trump) had. The language was actually made even more restrictive about including basic sidewalk bridge signage (Item #29). This leaves us in a hard place as we need to have the permit signed today in order to have the sidewalk bridge up for our VIP event on the 23rd.

I know that some conversations are taking place on this, but anything you can do to address this as well would be greatly appreciated. Though it is not ideal, we could live with the idea that we need to come back to approve any signage. We just do not want the permit to say that it is forbidden.

Dave

David Orowitz
Senior Vice President, Acquisitions and Development

The Trump Organization

725 Fifth Avenue | New York, NY | 10022
p. 212.836.3252 | m. 646.315.4698 | f. 212.836.3202

dorowitz@trumporg.com | trump.com

From: Woodbury, Brian [mailto:brian_woodbury@nps.gov]
Sent: Friday, July 11, 2014 9:38 AM
To: David Orowitz
Subject: Re: Follow-up to Call

Hi David,

I hope you are well. I don't have confirmation that the permit has been signed yet but it is close. Georgeann Smale from my office dogged this pretty hard to obtain solicitor review and to get the park personnel on board. I would be grateful if you could just send her a quick note recognizing her efforts.

Kind regards,

Brian

On Thu, Jul 3, 2014 at 1:03 PM, David Orowitz <dorowitz@trumporg.com> wrote:

Brian,

It was good speaking to you earlier and thank you for your focus on getting this permit finalized. As requested, here is a bit more context on the work that we need to do as well as the timeline. NPS had asked that we combine two pieces of work under this single permit.

1) Sidewalk bridge – attached are shop drawings of the sidewalk bridge. These were developed by the fabricator (they show more detail than what is included in a permit application). We are planning to have a ground breaking event with the Mayor, Congresswoman Norton, and other members of the City Council and Congress on July 23rd. In order to be sure that the bridge is up in time for this event, we need to have the permit no later than July 8th.

2) Curb cut – as you mentioned, the curb cut has already been approved as part of the transfer of jurisdiction. Since the work will peripherally impact portions of NPS jurisdiction as originally designed, we need the permit to allow for the work.

I hope this context is helpful. If any additional information is required, please let me know. Thanks again for doing whatever you can to get this finalized by first thing next week.

Best,

Dave

David Orowitz

Senior Vice President, Acquisitions and Development

The Trump Organization

725 Fifth Avenue | New York, NY | 10022
p. 212.836.3252 | m. 646.315.4698 | f. 212.836.3202

dorowitz@trumporg.com | trump.com

This e-mail message, and any attachments to it, are for the sole use of the intended recipients, and may contain confidential and privileged information. Any unauthorized review, use, disclosure or distribution of this email message or its attachments is prohibited. If you are not the intended recipient, please contact the sender by reply email and destroy all copies of the original message. Please note that any views or opinions presented in this email are solely those of the author and do not necessarily represent those of the company. Finally, while the company uses virus protection, the recipient should check this email and any attachments for the presence of viruses. The company accepts no liability for any damage caused by any virus transmitted by this email.

--

Brian M. Woodbury
Chief of Lands
National Park Service - National Capital Region
1100 Ohio Drive, SW
Washington, DC 20242
(202) 619.7034
brian_woodbury@nps.gov

--

Brian M. Woodbury
Chief of Lands
National Park Service - National Capital Region
1100 Ohio Drive, SW
Washington, DC 20242
(202) 619.7034
brian_woodbury@nps.gov

Re_ Follow-up to Call(2).pdf

From: [Woodbury, Brian](#)
To: [David Orowitz](#)
Subject: Re: Follow-up to Call
Date: Friday, July 11, 2014 9:26:24 AM

David,

We are working to straighten this out now. The easiest thing right now is for the language to be changed to reflect that you will need to come back to have the signage approved by the NPS.

I will let you know as it progresses.

-Brian

On Fri, Jul 11, 2014 at 10:42 AM, David Orowitz <dorowitz@trumporg.com> wrote:

Brian,

Hope you are well also. Unfortunately, the permit that was sent yesterday did not address the only comment that we (Trump) had. The language was actually made even more restrictive about including basic sidewalk bridge signage (Item #29). This leaves us in a hard place as we need to have the permit signed today in order to have the sidewalk bridge up for our VIP event on the 23rd.

I know that some conversations are taking place on this, but anything you can do to address this as well would be greatly appreciated. Though it is not ideal, we could live with the idea that we need to come back to approve any signage. We just do not want the permit to say that it is forbidden.

Dave

David Orowitz
Senior Vice President, Acquisitions and Development

The Trump Organization

725 Fifth Avenue | New York, NY | 10022
p. 212.836.3252 | m. 646.315.4698 | f. 212.836.3202

dorowitz@trumporg.com | trump.com

From: Woodbury, Brian [mailto:brian_woodbury@nps.gov]
Sent: Friday, July 11, 2014 9:38 AM
To: David Orowitz
Subject: Re: Follow-up to Call

Hi David,

I hope you are well. I don't have confirmation that the permit has been signed yet but it is close. Georgeann Smale from my office dogged this pretty hard to obtain solicitor review and to get the park personnel on board. I would be grateful if you could just send her a quick note recognizing her efforts.

Kind regards,

Brian

On Thu, Jul 3, 2014 at 1:03 PM, David Orowitz <dorowitz@trumporg.com> wrote:

Brian,

It was good speaking to you earlier and thank you for your focus on getting this permit finalized. As requested, here is a bit more context on the work that we need to do as well as the timeline. NPS had asked that we combine two pieces of work under this single permit.

- 1) Sidewalk bridge – attached are shop drawings of the sidewalk bridge. These were developed by the fabricator (they show more detail than what is included in a permit application). We are planning to have a ground breaking event with the Mayor, Congresswoman Norton, and other members of the City Council and Congress on July 23rd. In order to be sure that the bridge is up in time for this event, we need to have the permit no later than July 8th.
- 2) Curb cut – as you mentioned, the curb cut has already been approved as part of the transfer of jurisdiction. Since the work will peripherally impact portions of NPS jurisdiction as originally designed, we need the permit to allow for the work.

I hope this context is helpful. If any additional information is required, please let me know. Thanks again for doing whatever you can to get this finalized by first thing next week.

Best,

Dave

David Orowitz

Senior Vice President, Acquisitions and Development

The Trump Organization

725 Fifth Avenue | New York, NY | 10022
p. 212.836.3252 | m. 646.315.4698 | f. 212.836.3202

dorowitz@trumporg.com | trump.com

This e-mail message, and any attachments to it, are for the sole use of the intended recipients, and may contain confidential and privileged information. Any unauthorized review, use, disclosure or distribution of this email message or its attachments is prohibited. If you are not the intended recipient, please contact the sender by reply email and destroy all copies of the original message. Please note that any views or opinions presented in this email are solely those of the author and do not necessarily represent those of the company. Finally, while the company uses virus protection, the recipient should check this email and any attachments for the presence of viruses. The company accepts no liability for any damage caused by any virus transmitted by this email.

--

Brian M. Woodbury
Chief of Lands
National Park Service - National Capital Region
1100 Ohio Drive, SW
Washington, DC 20242
(202) 619.7034
brian_woodbury@nps.gov

--

Brian M. Woodbury

Chief of Lands
National Park Service - National Capital Region
1100 Ohio Drive, SW
Washington, DC 20242
(202) 619.7034
brian_woodbury@nps.gov

RE_ Follow-up to Call(1)_1.pdf

From: [David Orowitz](#)
To: [Woodbury, Brian](#)
Subject: RE: Follow-up to Call
Date: Friday, July 11, 2014 9:28:07 AM

We understand that and can get comfortable with it. Thanks for your help with this.

David Orowitz
Senior Vice President, Acquisitions and Development
The Trump Organization
725 Fifth Avenue | New York, NY | 10022
p. 212.836.3252 | m. 646.315.4698 | f. 212.836.3202
dorowitz@trumporg.com | trump.com

From: Woodbury, Brian [mailto:brian_woodbury@nps.gov]
Sent: Friday, July 11, 2014 11:26 AM
To: David Orowitz
Subject: Re: Follow-up to Call

David,

We are working to straighten this out now. The easiest thing right now is for the language to be changed to reflect that you will need to come back to have the signage approved by the NPS.

I will let you know as it progresses.

-Brian

On Fri, Jul 11, 2014 at 10:42 AM, David Orowitz <dorowitz@trumporg.com> wrote:
Brian,

Hope you are well also. Unfortunately, the permit that was sent yesterday did not address the only comment that we (Trump) had. The language was actually made even more restrictive about including basic sidewalk bridge signage (Item #29). This leaves us in a hard place as we need to have the permit signed today in order to have the sidewalk bridge up for our VIP event on the 23rd.

I know that some conversations are taking place on this, but anything you can do to address this as well would be greatly appreciated. Though it is not ideal, we could live with the idea that we need to come back to approve any signage. We just do not want the permit to say that it is forbidden.

Dave

David Orowitz
Senior Vice President, Acquisitions and Development
The Trump Organization
725 Fifth Avenue | New York, NY | 10022
p. 212.836.3252 | m. 646.315.4698 | f. 212.836.3202
dorowitz@trumporg.com | trump.com

From: Woodbury, Brian [mailto:brian_woodbury@nps.gov]

Sent: Friday, July 11, 2014 9:38 AM
To: David Orowitz
Subject: Re: Follow-up to Call

Hi David,

I hope you are well. I don't have confirmation that the permit has been signed yet but it is close. Georgeann Smale from my office dogged this pretty hard to obtain solicitor review and to get the park personnel on board. I would be grateful if you could just send her a quick note recognizing her efforts.

Kind regards,

Brian

On Thu, Jul 3, 2014 at 1:03 PM, David Orowitz <dorowitz@trumporg.com> wrote:
Brian,

It was good speaking to you earlier and thank you for your focus on getting this permit finalized. As requested, here is a bit more context on the work that we need to do as well as the timeline. NPS had asked that we combine two pieces of work under this single permit.

1) Sidewalk bridge – attached are shop drawings of the sidewalk bridge. These were developed by the fabricator (they show more detail than what is included in a permit application). We are planning to have a ground breaking event with the Mayor, Congresswoman Norton, and other members of the City Council and Congress on July 23rd. In order to be sure that the bridge is up in time for this event, we need to have the permit no later than July 8th.

2) Curb cut – as you mentioned, the curb cut has already been approved as part of the transfer of jurisdiction. Since the work will peripherally impact portions of NPS jurisdiction as originally designed, we need the permit to allow for the work.

I hope this context is helpful. If any additional information is required, please let me know. Thanks again for doing whatever you can to get this finalized by first thing next week.

Best,
Dave

David Orowitz
Senior Vice President, Acquisitions and Development
The Trump Organization
725 Fifth Avenue | New York, NY | 10022
p. 212.836.3252 | m. 646.315.4698 | f. 212.836.3202
dorowitz@trumporg.com | trump.com

This e-mail message, and any attachments to it, are for the sole use of the intended recipients, and may contain confidential and privileged information. Any unauthorized review, use, disclosure or distribution of this email message or its attachments is prohibited. If you are not the intended recipient, please contact the sender by reply email and destroy all copies of the

original message. Please note that any views or opinions presented in this email are solely those of the author and do not necessarily represent those of the company. Finally, while the company uses virus protection, the recipient should check this email and any attachments for the presence of viruses. The company accepts no liability for any damage caused by any virus transmitted by this email.

--

Brian M. Woodbury
Chief of Lands
National Park Service - National Capital Region
1100 Ohio Drive, SW
Washington, DC 20242
(202) 619.7034
brian_woodbury@nps.gov

--

Brian M. Woodbury
Chief of Lands
National Park Service - National Capital Region
1100 Ohio Drive, SW
Washington, DC 20242
(202) 619.7034
brian_woodbury@nps.gov

Re_ Follow-up to Call(3).pdf

From: [Woodbury, Brian](#)
To: [David Orowitz](#)
Subject: Re: Follow-up to Call
Date: Friday, July 11, 2014 12:08:14 PM

Hi David,

I'm afraid that I cannot be more helpful in having the language in paragraph 29 modified. I left a message for Brett Banks as well.

Kind regards,

Brian

On Fri, Jul 11, 2014 at 11:29 AM, David Orowitz <dorowitz@trumporg.com> wrote:

We understand that and can get comfortable with it. Thanks for your help with this.

David Orowitz
Senior Vice President, Acquisitions and Development

The Trump Organization

725 Fifth Avenue | New York, NY | 10022
p. 212.836.3252 | m. 646.315.4698 | f. 212.836.3202

dorowitz@trumporg.com | trump.com

From: Woodbury, Brian [mailto:brian_woodbury@nps.gov]
Sent: Friday, July 11, 2014 11:26 AM
To: David Orowitz
Subject: Re: Follow-up to Call

David,

We are working to straighten this out now. The easiest thing right now is for the language to be changed to reflect that you will need to come back to have the signage approved by the NPS.

I will let you know as it progresses.

-Brian

On Fri, Jul 11, 2014 at 10:42 AM, David Orowitz <dorowitz@trumporg.com> wrote:

Brian,

Hope you are well also. Unfortunately, the permit that was sent yesterday did not address the only comment that we (Trump) had. The language was actually made even more restrictive about including basic sidewalk bridge signage (Item #29). This leaves us in a hard place as we need to have the permit signed today in order to have the sidewalk bridge up for our VIP event on the 23rd.

I know that some conversations are taking place on this, but anything you can do to address this as well would be greatly appreciated. Though it is not ideal, we could live with the idea that we need to come back to approve any signage. We just do not want the permit to say that it is forbidden.

Dave

David Orowitz
Senior Vice President, Acquisitions and Development

The Trump Organization

725 Fifth Avenue | New York, NY | 10022
p. 212.836.3252 | m. 646.315.4698 | f. 212.836.3202

dorowitz@trumporg.com | trump.com

From: Woodbury, Brian [mailto:brian_woodbury@nps.gov]
Sent: Friday, July 11, 2014 9:38 AM
To: David Orowitz
Subject: Re: Follow-up to Call

Hi David,

I hope you are well. I don't have confirmation that the permit has been signed yet but it is close. Georgeann Smale from my office dogged this pretty hard to obtain solicitor review

and to get the park personnel on board. I would be grateful if you could just send her a quick note recognizing her efforts.

Kind regards,

Brian

On Thu, Jul 3, 2014 at 1:03 PM, David Orowitz <dorowitz@trumporg.com> wrote:

Brian,

It was good speaking to you earlier and thank you for your focus on getting this permit finalized. As requested, here is a bit more context on the work that we need to do as well as the timeline. NPS had asked that we combine two pieces of work under this single permit.

- 1) Sidewalk bridge – attached are shop drawings of the sidewalk bridge. These were developed by the fabricator (they show more detail than what is included in a permit application). We are planning to have a ground breaking event with the Mayor, Congresswoman Norton, and other members of the City Council and Congress on July 23rd. In order to be sure that the bridge is up in time for this event, we need to have the permit no later than July 8th.
- 2) Curb cut – as you mentioned, the curb cut has already been approved as part of the transfer of jurisdiction. Since the work will peripherally impact portions of NPS jurisdiction as originally designed, we need the permit to allow for the work.

I hope this context is helpful. If any additional information is required, please let me know. Thanks again for doing whatever you can to get this finalized by first thing next week.

Best,

Dave

David Orowitz
Senior Vice President, Acquisitions and Development

The Trump Organization

725 Fifth Avenue | New York, NY | 10022

dorowitz@trumporg.com | trump.com

This e-mail message, and any attachments to it, are for the sole use of the intended recipients, and may contain confidential and privileged information. Any unauthorized review, use, disclosure or distribution of this email message or its attachments is prohibited. If you are not the intended recipient, please contact the sender by reply email and destroy all copies of the original message. Please note that any views or opinions presented in this email are solely those of the author and do not necessarily represent those of the company. Finally, while the company uses virus protection, the recipient should check this email and any attachments for the presence of viruses. The company accepts no liability for any damage caused by any virus transmitted by this email.

--

Brian M. Woodbury
Chief of Lands
National Park Service - National Capital Region
1100 Ohio Drive, SW
Washington, DC 20242
(202) 619.7034
brian_woodbury@nps.gov

--

Brian M. Woodbury
Chief of Lands
National Park Service - National Capital Region
1100 Ohio Drive, SW
Washington, DC 20242
(202) 619.7034
brian_woodbury@nps.gov

--

Brian M. Woodbury
Chief of Lands
National Park Service - National Capital Region
1100 Ohio Drive, SW
Washington, DC 20242
(202) 619.7034
brian_woodbury@nps.gov

RE_ Follow-up to Call(2)_1.pdf

From: [David Orowitz](#)
To: [Woodbury, Brian](#)
Subject: RE: Follow-up to Call
Date: Friday, July 11, 2014 12:11:21 PM

Brian,

Thanks. The permit is signed. I think that we have a path forward. Thanks for all of your help.

Best,
Dave

David Orowitz
Senior Vice President, Acquisitions and Development
The Trump Organization
725 Fifth Avenue | New York, NY | 10022
p. 212.836.3252 | m. 646.315.4698 | f. 212.836.3202
dorowitz@trumporg.com | trump.com

From: Woodbury, Brian [mailto:brian_woodbury@nps.gov]
Sent: Friday, July 11, 2014 2:08 PM
To: David Orowitz
Subject: Re: Follow-up to Call

Hi David,

I'm afraid that I cannot be more helpful in having the language in paragraph 29 modified. I left a message for Brett Banks as well.

Kind regards,

Brian

On Fri, Jul 11, 2014 at 11:29 AM, David Orowitz <dorowitz@trumporg.com> wrote:
We understand that and can get comfortable with it. Thanks for your help with this.

David Orowitz
Senior Vice President, Acquisitions and Development
The Trump Organization
725 Fifth Avenue | New York, NY | 10022
p. 212.836.3252 | m. 646.315.4698 | f. 212.836.3202
dorowitz@trumporg.com | trump.com

From: Woodbury, Brian [mailto:brian_woodbury@nps.gov]
Sent: Friday, July 11, 2014 11:26 AM
To: David Orowitz
Subject: Re: Follow-up to Call

David,

We are working to straighten this out now. The easiest thing right now is for the language to be changed to reflect that you will need to come back to have the signage approved by the

NPS.

I will let you know as it progresses.

-Brian

On Fri, Jul 11, 2014 at 10:42 AM, David Orowitz <dorowitz@trumporg.com> wrote:
Brian,

Hope you are well also. Unfortunately, the permit that was sent yesterday did not address the only comment that we (Trump) had. The language was actually made even more restrictive about including basic sidewalk bridge signage (Item #29). This leaves us in a hard place as we need to have the permit signed today in order to have the sidewalk bridge up for our VIP event on the 23rd.

I know that some conversations are taking place on this, but anything you can do to address this as well would be greatly appreciated. Though it is not ideal, we could live with the idea that we need to come back to approve any signage. We just do not want the permit to say that it is forbidden.

Dave

David Orowitz
Senior Vice President, Acquisitions and Development
The Trump Organization
725 Fifth Avenue | New York, NY | 10022
p. 212.836.3252 | m. 646.315.4698 | f. 212.836.3202
dorowitz@trumporg.com | trump.com

From: Woodbury, Brian [mailto:brian_woodbury@nps.gov]
Sent: Friday, July 11, 2014 9:38 AM
To: David Orowitz
Subject: Re: Follow-up to Call

Hi David,

I hope you are well. I don't have confirmation that the permit has been signed yet but it is close. Georgeann Smale from my office dogged this pretty hard to obtain solicitor review and to get the park personnel on board. I would be grateful if you could just send her a quick note recognizing her efforts.

Kind regards,

Brian

On Thu, Jul 3, 2014 at 1:03 PM, David Orowitz <dorowitz@trumporg.com> wrote:
Brian,

It was good speaking to you earlier and thank you for your focus on getting this permit finalized. As requested, here is a bit more context on the work that we need to do as well as the timeline. NPS had asked that we combine two pieces of work under this single permit.

1) Sidewalk bridge – attached are shop drawings of the sidewalk bridge. These were developed by the fabricator (they show more detail than what is included in a permit application). We are planning to have a ground breaking event with the Mayor, Congresswoman Norton, and other members of the City Council and Congress on July 23rd. In order to be sure that the bridge is up in time for this event, we need to have the permit no later than July 8th.

2) Curb cut – as you mentioned, the curb cut has already been approved as part of the transfer of jurisdiction. Since the work will peripherally impact portions of NPS jurisdiction as originally designed, we need the permit to allow for the work.

I hope this context is helpful. If any additional information is required, please let me know. Thanks again for doing whatever you can to get this finalized by first thing next week.

Best,
Dave

David Orowitz
Senior Vice President, Acquisitions and Development
The Trump Organization
725 Fifth Avenue | New York, NY | 10022
p. 212.836.3252 | m. 646.315.4698 | f. 212.836.3202
dorowitz@trumporg.com | trump.com

This e-mail message, and any attachments to it, are for the sole use of the intended recipients, and may contain confidential and privileged information. Any unauthorized review, use, disclosure or distribution of this email message or its attachments is prohibited. If you are not the intended recipient, please contact the sender by reply email and destroy all copies of the original message. Please note that any views or opinions presented in this email are solely those of the author and do not necessarily represent those of the company. Finally, while the company uses virus protection, the recipient should check this email and any attachments for the presence of viruses. The company accepts no liability for any damage caused by any virus transmitted by this email.

--

Brian M. Woodbury
Chief of Lands
National Park Service - National Capital Region
1100 Ohio Drive, SW
Washington, DC 20242
(202) 619.7034
brian_woodbury@nps.gov

--

Brian M. Woodbury
Chief of Lands
National Park Service - National Capital Region
1100 Ohio Drive, SW
Washington, DC 20242
(202) 619.7034
brian_woodbury@nps.gov

--

Brian M. Woodbury
Chief of Lands
National Park Service - National Capital Region
1100 Ohio Drive, SW
Washington, DC 20242
(202) 619.7034
brian_woodbury@nps.gov

Re_ An Invitation from the Trump Family.pdf

From: [Goeken, Brian](#)
To: [Shireen Cohen](#)
Subject: Re: An Invitation from the Trump Family
Date: Friday, July 11, 2014 3:15:33 PM

Shireen,
Yes, I will be attending.

Also, are you able to tell me who else from the National Park Service or the Department of the Interior has been invited? If it was sent by email, I can make sure that they got it.

Thanks,
Brian

Brian Goeken, AICP
Chief, Technical Preservation Services
National Park Service

On Thu, Jul 10, 2014 at 5:30 PM, Shireen Cohen <scohen@trumporg.com> wrote:



DONALD J. TRUMP

ALONG WITH DONALD JR., IVANKA & ERIC TRUMP

*Invite you to celebrate the commencement of construction of the
Trump International Hotel, Washington D.C.*

WEDNESDAY, JULY 23, 2014

10:00 AM

THE OLD POST OFFICE
1100 PENNSYLVANIA AVENUE NW
OUTDOOR MAIN STEPS

*RSVP by July 18 to
scohen@trumporg.com*

This e-mail message, and any attachments to it, are for the sole use of the intended recipients, and may contain confidential and privileged information. Any unauthorized review, use, disclosure or distribution of this email message or its attachments is prohibited. If you are not the intended recipient, please contact the sender by reply email and destroy all copies of the original message. Please note that any views or opinions presented in this email are solely those of the author and do not necessarily represent those of the company. Finally, while the company uses virus protection, the recipient should check this email and any attachments for the presence of viruses. The company accepts no liability for any damage caused by any virus transmitted by this email.

--

Brian Goeken, AICP
Chief, Technical Preservation Services
National Park Service

Mail:
1849 C Street NW - Org code 2255
Washington, DC 20240

Overnight delivery:
1201 'Eye' Street NW
Floor 6-015
Washington, DC 20005

202-354-2033 phone
202-371-1616 fax
Brian_Goeken@nps.gov

Website: www.nps.gov/tps

Like us on facebook! [Heritage & Historic Preservation - NPS](#)

Follow us on Twitter: [@HHPreservItNPS](#)

RSVP for Old Post Office reception...7_23_14.pdf

From: [Tepper, Audrey](#)
To: scohen@trumporg.com
Subject: RSVP for Old Post Office reception...7/23/14
Date: Monday, July 14, 2014 8:33:05 AM

I will attend the Old Post Office reception on July 23.

Thanks for the invite!

--

Audrey T. Tepper - LEED Green Associate
Historical Architect
National Park Service
Technical Preservation Services Branch
1201 Eye Street, NW - Org. 2200
Washington, DC 20005
202-354-2027
202-371-1616 (FAX)
audrey_tepper@nps.gov

Re_ An Invitation from the Trump Family(1).pdf

From: [Goeken, Brian](#)
To: [Shireen Cohen](#)
Subject: Re: An Invitation from the Trump Family
Date: Monday, July 14, 2014 1:27:57 PM
Attachments: [image001.png](#)

thanks, Shireen. much appreciated.

On Mon, Jul 14, 2014 at 1:58 PM, Shireen Cohen <scohen@trumporg.com> wrote:

Hi Brian,

I hope this email finds you well and you had a fantastic weekend!

As of now we have invited Audrey Tepper, John Sandor, Peter May, Brian Woodbury, Robert Vogel, Steve Lorenzetti, Jon Jarvis, Robin Nixon and Carol Richard from the National Park Service. If you would like us to extend an invite to anyone else from the department we'd be happy to send along!

Best,

Shireen

T R U M P

THE TRUMP ORGANIZATION

Shireen Cohen
Marketing Coordinator

725 Fifth Avenue | New York, NY | 10022
p. 212.715.6787

scohen@trumporg.com | trump.com

From: Goeken, Brian [mailto:brian_goeken@nps.gov]
Sent: Friday, July 11, 2014 5:16 PM
To: Shireen Cohen
Subject: Re: An Invitation from the Trump Family

Shireen,

Yes, I will be attending.

Also, are you able to tell me who else from the National Park Service or the Department of the Interior has been invited? If it was sent by email, I can make sure that they got it.

Thanks,

Brian

Brian Goeken, AICP

Chief, Technical Preservation Services

National Park Service

On Thu, Jul 10, 2014 at 5:30 PM, Shireen Cohen <scohen@trumporg.com> wrote:



DONALD J. TRUMP

ALONG WITH DONALD JR., IVANKA & ERIC TRUMP

*Invite you to celebrate the commencement of construction of the
Trump International Hotel, Washington D.C.*

WEDNESDAY, JULY 23, 2014

10:00 AM

THE OLD POST OFFICE
1100 PENNSYLVANIA AVENUE NW
OUTDOOR MAIN STEPS

*RSVP by July 18 to
scohen@trumporg.com*

This e-mail message, and any attachments to it, are for the sole use of the intended recipients, and may contain confidential and privileged information. Any unauthorized review, use, disclosure or distribution of this email message or its attachments is prohibited. If you are not the intended recipient, please contact the sender by reply email and destroy all copies of the original message. Please note that any views or opinions presented in this email are solely those of the author and do not necessarily represent those of the company. Finally, while the company uses virus protection, the recipient should check this email and any attachments for the presence of viruses. The company accepts no liability for any damage caused by any virus transmitted by this email.

--

Brian Goeken, AICP

Chief, Technical Preservation Services

National Park Service

Mail:

1849 C Street NW - Org code 2255

Washington, DC 20240

Overnight delivery:

1201 'Eye' Street NW

Floor 6-015

Washington, DC 20005

202-354-2033 phone

202-371-1616 fax

Brian_Goeken@nps.gov

Website: www.nps.gov/tps

Like us on facebook! [Heritage & Historic Preservation - NPS](#)

Follow us on Twitter: [@HHPreservItNPS](#)

--

Brian Goeken, AICP
Chief, Technical Preservation Services
National Park Service

Mail:

1849 C Street NW - Org code 2255

Washington, DC 20240

Overnight delivery:

1201 'Eye' Street NW

Floor 6-015
Washington, DC 20005

202-354-2033 phone
202-371-1616 fax
Brian_Goeken@nps.gov

Website: www.nps.gov/tps
Like us on facebook! [Heritage & Historic Preservation - NPS](#)
Follow us on Twitter: [@HHPreservItNPS](#)

Re_ An Invitation from the Trump Family(2).pdf

From: [Goeken, Brian](#)
To: [Shireen Cohen](#); [Stephanie Toothman](#)
Subject: Re: An Invitation from the Trump Family
Date: Monday, July 14, 2014 1:56:41 PM
Attachments: [image001.png](#)

Shireen,

Can you please send invitations to the National Park Service's Peggy O'Dell, Deputy Director of Operations, and Stephanie Toothman, Associate Director of Cultural Resources, Partnerships and Science? Their email addresses are as follows:

peggy_o'dell@nps.gov
stephanie_toothman@nps.gov

Thanks,
Brian

On Mon, Jul 14, 2014 at 3:27 PM, Goeken, Brian <brian_goeken@nps.gov> wrote:
thanks, Shireen. much appreciated.

On Mon, Jul 14, 2014 at 1:58 PM, Shireen Cohen <scohen@trumporg.com> wrote:

Hi Brian,

I hope this email finds you well and you had a fantastic weekend!

As of now we have invited Audrey Tepper, John Sandor, Peter May, Brian Woodbury, Robert Vogel, Steve Lorenzetti, Jon Jarvis, Robin Nixon and Carol Richard from the National Park Service. If you would like us to extend an invite to anyone else from the department we'd be happy to send along!

Best,

Shireen

TRUMP

THE TRUMP ORGANIZATION

Shireen Cohen
Marketing Coordinator

725 Fifth Avenue | New York, NY | 10022
p. 212.715.6787

scohen@trumporg.com | trump.com

From: Goeken, Brian [mailto:brian_goeken@nps.gov]
Sent: Friday, July 11, 2014 5:16 PM
To: Shireen Cohen
Subject: Re: An Invitation from the Trump Family

Shireen,

Yes, I will be attending.

Also, are you able to tell me who else from the National Park Service or the Department of the Interior has been invited? If it was sent by email, I can make sure that they got it.

Thanks,

Brian

Brian Goeken, AICP

Chief, Technical Preservation Services

National Park Service

On Thu, Jul 10, 2014 at 5:30 PM, Shireen Cohen <scohen@trumporg.com> wrote:

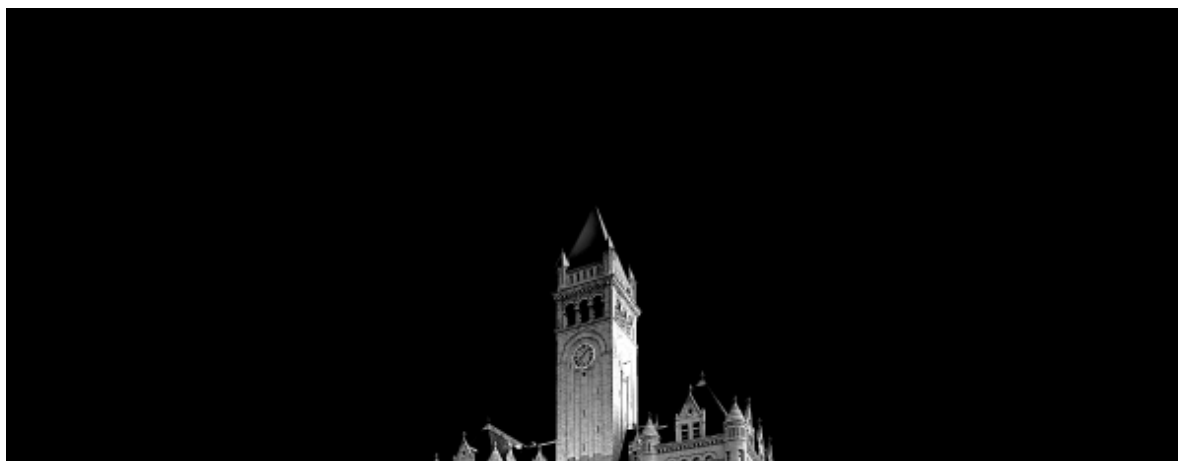



TRUMP

INTERNATIONAL HOTEL

WASHINGTON, D.C.

DONALD J. TRUMP

ALONG WITH DONALD JR., IVANKA & ERIC TRUMP

*Invite you to celebrate the commencement of construction of the
Trump International Hotel, Washington D.C.*

WEDNESDAY, JULY 23, 2014

10:00 AM

THE OLD POST OFFICE
1100 PENNSYLVANIA AVENUE NW
OUTDOOR MAIN STEPS

RSVP by July 18 to

scohen@trumporg.com

This e-mail message, and any attachments to it, are for the sole use of the intended recipients, and may contain confidential and privileged information. Any unauthorized review, use, disclosure or distribution of this email message or its attachments is prohibited. If you are not the intended recipient, please contact the sender by reply email and destroy all copies of the original message. Please note that any views or opinions presented in this email are solely those of the author and do not necessarily represent those of the company.

Finally, while the company uses virus protection, the recipient should check this email and any attachments for the presence of viruses. The company accepts no liability for any damage caused by any virus transmitted by this email.

--

Brian Goeken, AICP

Chief, Technical Preservation Services

National Park Service

Mail:

1849 C Street NW - Org code 2255

Washington, DC 20240

Overnight delivery:

1201 'Eye' Street NW
Floor 6-015
Washington, DC 20005

202-354-2033 phone

202-371-1616 fax

Brian_Goeken@nps.gov

Website: www.nps.gov/tps

Like us on facebook! [Heritage & Historic Preservation - NPS](#)

Follow us on Twitter: [@HHPreservItNPS](#)

--

Brian Goeken, AICP
Chief, Technical Preservation Services
National Park Service

Mail:

1849 C Street NW - Org code 2255
Washington, DC 20240

Overnight delivery:

1201 'Eye' Street NW
Floor 6-015
Washington, DC 20005

202-354-2033 phone

202-371-1616 fax

Brian_Goeken@nps.gov

Website: www.nps.gov/tps

Like us on facebook! [Heritage & Historic Preservation - NPS](#)

Follow us on Twitter: [@HHPreservItNPS](#)

--

Brian Goeken, AICP
Chief, Technical Preservation Services
National Park Service

Mail:

1849 C Street NW - Org code 2255
Washington, DC 20240

Overnight delivery:

1201 'Eye' Street NW
Floor 6-015
Washington, DC 20005

202-354-2033 phone

202-371-1616 fax

Brian_Goeken@nps.gov

Website: www.nps.gov/tps

Like us on facebook! [Heritage & Historic Preservation - NPS](#)

Follow us on Twitter: [@HHPreservItNPS](#)

RE_ An Invitation from the Trump Family_1.pdf

From: [Shireen Cohen](#)
To: [Goeken, Brian](#); [Stephanie Toothman](#)
Subject: RE: An Invitation from the Trump Family
Date: Monday, July 14, 2014 2:00:42 PM
Attachments: [image001.png](#)

Hi Brian,
Absolutely! I will forward the invite to them shortly.

Best,
Shireen

T R U M P

THE TRUMP ORGANIZATION

Shireen Cohen
Marketing Coordinator
725 Fifth Avenue | New York, NY | 10022
p. 212.715.6787
scohen@trumporg.com | trump.com

From: Goeken, Brian [mailto:brian_goeken@nps.gov]
Sent: Monday, July 14, 2014 3:57 PM
To: Shireen Cohen; Stephanie Toothman
Subject: Re: An Invitation from the Trump Family

Shireen,
Can you please send invitations to the National Park Service's Peggy O'Dell, Deputy Director of Operations, and Stephanie Toothman, Associate Director of Cultural Resources, Partnerships and Science? Their email addresses are as follows:

peggy_o'dell@nps.gov
stephanie_toothman@nps.gov

Thanks,
Brian

On Mon, Jul 14, 2014 at 3:27 PM, Goeken, Brian <brian_goeken@nps.gov> wrote:
thanks, Shireen. much appreciated.

On Mon, Jul 14, 2014 at 1:58 PM, Shireen Cohen <scohen@trumporg.com> wrote:
Hi Brian,

I hope this email finds you well and you had a fantastic weekend!
As of now we have invited Audrey Tepper, John Sandor, Peter May, Brian Woodbury, Robert Vogel, Steve Lorenzetti, Jon Jarvis, Robin Nixon and Carol Richard from the National Park Service. If you would like us to extend an invite to anyone else from the department we'd be happy to send along!

Best,

Shireen

T R U M P
THE TRUMP ORGANIZATION

Shireen Cohen
Marketing Coordinator
725 Fifth Avenue | New York, NY | 10022
p. 212.715.6787
scohen@trumporg.com | trump.com

From: Goeken, Brian [mailto:brian_goeken@nps.gov]
Sent: Friday, July 11, 2014 5:16 PM
To: Shireen Cohen
Subject: Re: An Invitation from the Trump Family

Shireen,
Yes, I will be attending.

Also, are you able to tell me who else from the National Park Service or the Department of the Interior has been invited? If it was sent by email, I can make sure that they got it.

Thanks,
Brian

Brian Goeken, AICP
Chief, Technical Preservation Services
National Park Service

On Thu, Jul 10, 2014 at 5:30 PM, Shireen Cohen <scohen@trumporg.com> wrote:

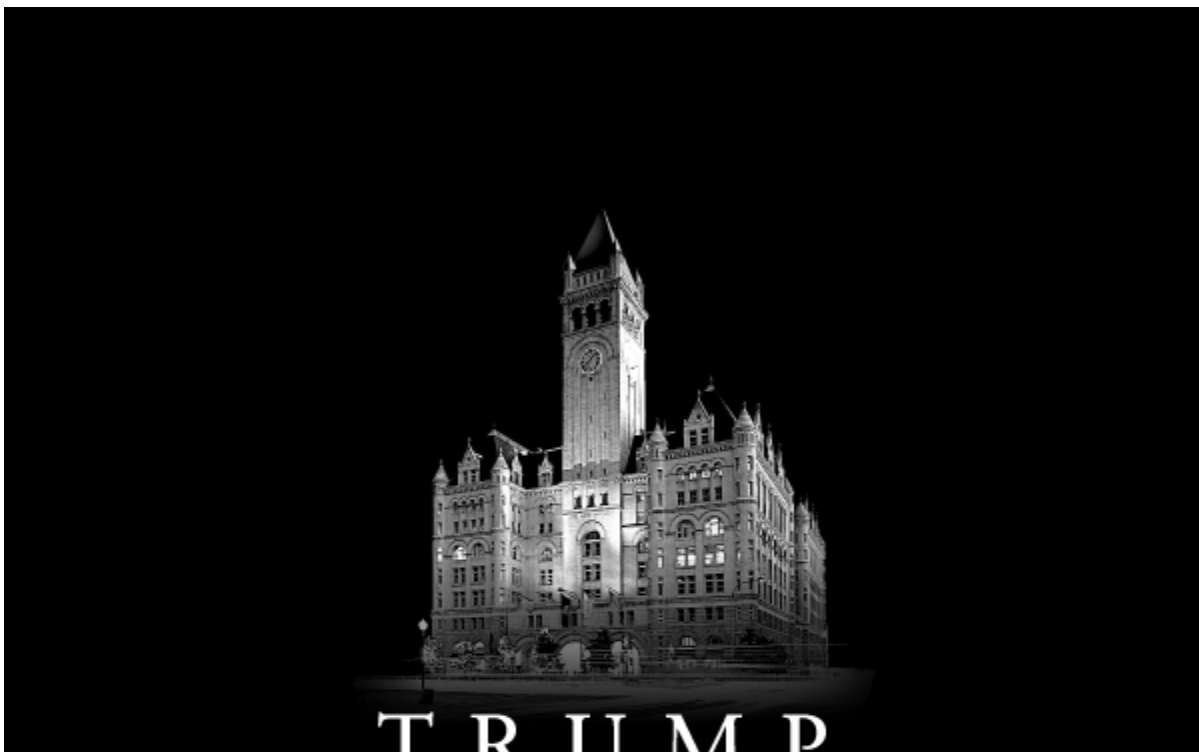

TRUMP
INTERNATIONAL HOTEL
WASHINGTON, D.C.

DONALD J. TRUMP

ALONG WITH DONALD JR., IVANKA & ERIC TRUMP

*Invite you to celebrate the commencement of construction of the
Trump International Hotel, Washington D.C.*

WEDNESDAY, JULY 23, 2014
10:00 AM

THE OLD POST OFFICE
1100 PENNSYLVANIA AVENUE NW
OUTDOOR MAIN STEPS

*RSVP by July 18 to
scohen@trumporg.com*

This e-mail message, and any attachments to it, are for the sole use of the intended recipients, and may contain confidential and privileged information. Any unauthorized review, use, disclosure or distribution of this email message or its attachments is prohibited. If you are not the intended recipient, please contact the sender by reply email and destroy all copies of the original message. Please note that any views or opinions presented in this email are solely those of the author and do not necessarily represent those of the company. Finally, while the company uses virus protection, the recipient should check this email and any attachments for the presence of viruses. The company accepts no liability for any damage caused by any virus transmitted by this email.

--

Brian Goeken, AICP

Chief, Technical Preservation Services
National Park Service

Mail:

1849 C Street NW - Org code 2255
Washington, DC 20240

Overnight delivery:

1201 'Eye' Street NW
Floor 6-015
Washington, DC 20005

202-354-2033 phone

202-371-1616 fax

Brian_Goeken@nps.gov

Website: www.nps.gov/tps

Like us on facebook! [Heritage & Historic Preservation - NPS](#)

Follow us on Twitter: [@HHPreservItNPS](#)

--

Brian Goeken, AICP
Chief, Technical Preservation Services
National Park Service

Mail:

1849 C Street NW - Org code 2255
Washington, DC 20240

Overnight delivery:

1201 'Eye' Street NW
Floor 6-015
Washington, DC 20005

202-354-2033 phone

202-371-1616 fax

Brian_Goeken@nps.gov

Website: www.nps.gov/tps

Like us on facebook! [Heritage & Historic Preservation - NPS](#)

Follow us on Twitter: [@HHPreservItNPS](#)

--

Brian Goeken, AICP

Chief, Technical Preservation Services
National Park Service

Mail:

1849 C Street NW - Org code 2255
Washington, DC 20240

Overnight delivery:

1201 'Eye' Street NW
Floor 6-015
Washington, DC 20005

202-354-2033 phone

202-371-1616 fax

Brian_Goeken@nps.gov

Website: www.nps.gov/tps

Like us on facebook! [Heritage & Historic Preservation - NPS](#)

Follow us on Twitter: [@HHPreservItNPS](#)

Re_ An Invitation from the Trump Family(3).pdf

From: [Goeken, Brian](#)
To: [Shireen Cohen](#)
Subject: Re: An Invitation from the Trump Family
Date: Monday, July 14, 2014 2:09:21 PM
Attachments: [image001.png](#)

thanks

On Mon, Jul 14, 2014 at 4:02 PM, Shireen Cohen <scohen@trumporg.com> wrote:

Hi Brian,

Absolutely! I will forward the invite to them shortly.

Best,

Shireen

T R U M P

THE TRUMP ORGANIZATION

Shireen Cohen
Marketing Coordinator

725 Fifth Avenue | New York, NY | 10022
p. 212.715.6787

scohen@trumporg.com | trump.com

From: Goeken, Brian [mailto:brian_goeken@nps.gov]
Sent: Monday, July 14, 2014 3:57 PM
To: Shireen Cohen; Stephanie Toothman

Subject: Re: An Invitation from the Trump Family

Shireen,

Can you please send invitations to the National Park Service's Peggy O'Dell, Deputy Director of Operations, and Stephanie Toothman, Associate Director of Cultural Resources, Partnerships and Science? Their email addresses are as follows:

peggy_o'dell@nps.gov
stephanie_toothman@nps.gov

Thanks,

Brian

On Mon, Jul 14, 2014 at 3:27 PM, Goeken, Brian <brian_goeken@nps.gov> wrote:
thanks, Shireen. much appreciated.

On Mon, Jul 14, 2014 at 1:58 PM, Shireen Cohen <scohen@trumporg.com> wrote:

Hi Brian,

I hope this email finds you well and you had a fantastic weekend!

As of now we have invited Audrey Tepper, John Sandor, Peter May, Brian Woodbury, Robert Vogel, Steve Lorenzetti, Jon Jarvis, Robin Nixon and Carol Richard from the National Park Service. If you would like us to extend an invite to anyone else from the department we'd be happy to send along!

Best,

Shireen

T R U M P

THE TRUMP ORGANIZATION

Shireen Cohen
Marketing Coordinator

725 Fifth Avenue | New York, NY | 10022
p. 212.715.6787

scohen@trumporg.com | trump.com

From: Goeken, Brian [mailto:brian_goeken@nps.gov]
Sent: Friday, July 11, 2014 5:16 PM
To: Shireen Cohen
Subject: Re: An Invitation from the Trump Family

Shireen,

Yes, I will be attending.

Also, are you able to tell me who else from the National Park Service or the Department of the Interior has been invited? If it was sent by email, I can make sure that they got it.

Thanks,

Brian

Brian Goeken, AICP

Chief, Technical Preservation Services

National Park Service

On Thu, Jul 10, 2014 at 5:30 PM, Shireen Cohen <scohen@trumporg.com> wrote:





TRUMP
INTERNATIONAL HOTEL
WASHINGTON, D.C.

DONALD J. TRUMP
ALONG WITH DONALD JR., IVANKA & ERIC TRUMP
*Invite you to celebrate the commencement of construction of the
Trump International Hotel, Washington D.C.*

WEDNESDAY, JULY 23, 2014
10:00 AM

THE OLD POST OFFICE
1100 PENNSYLVANIA AVENUE NW
OUTDOOR MAIN STEPS

*RSVP by July 18 to
scohen@trumporg.com*

This e-mail message, and any attachments to it, are for the sole use of the intended recipients, and may contain confidential and privileged information. Any unauthorized review, use, disclosure or distribution of this email message or its attachments is prohibited. If you are not the intended recipient, please contact the sender by reply email and destroy all copies of the original message. Please note that any views or opinions presented in this email are solely those of the author and do not necessarily represent those of the company.

Finally, while the company uses virus protection, the recipient should check this email and any attachments for the presence of viruses. The company accepts no liability for any damage caused by any virus transmitted by this email.

--

Brian Goeken, AICP

Chief, Technical Preservation Services

National Park Service

Mail:

1849 C Street NW - Org code 2255

Washington, DC 20240

Overnight delivery:

1201 'Eye' Street NW

Floor 6-015

Washington, DC 20005

202-354-2033 phone

202-371-1616 fax

Brian_Goeken@nps.gov

Website: www.nps.gov/tps

Like us on facebook! [Heritage & Historic Preservation - NPS](#)

Follow us on Twitter: [@HHPreservItNPS](#)

--

Brian Goeken, AICP

Chief, Technical Preservation Services

National Park Service

Mail:

1849 C Street NW - Org code 2255

Washington, DC 20240

Overnight delivery:

1201 'Eye' Street NW

Floor 6-015

Washington, DC 20005

202-354-2033 phone

202-371-1616 fax

Brian_Goeken@nps.gov

Website: www.nps.gov/tps

Like us on facebook! [Heritage & Historic Preservation - NPS](#)

Follow us on Twitter: [@HHPreservItNPS](#)

--

Brian Goeken, AICP

Chief, Technical Preservation Services

National Park Service

Mail:

1849 C Street NW - Org code 2255

Washington, DC 20240

Overnight delivery:

1201 'Eye' Street NW

Floor 6-015

Washington, DC 20005

202-354-2033 phone

202-371-1616 fax

Brian_Goeken@nps.gov

Website: www.nps.gov/tps

Like us on facebook! [Heritage & Historic Preservation - NPS](#)

Follow us on Twitter: [@HHPreservItNPS](#)

--

Brian Goeken, AICP
Chief, Technical Preservation Services
National Park Service

Mail:

1849 C Street NW - Org code 2255

Washington, DC 20240

Overnight delivery:

1201 'Eye' Street NW

Floor 6-015
Washington, DC 20005

202-354-2033 phone
202-371-1616 fax
Brian_Goeken@nps.gov

Website: www.nps.gov/tps
Like us on facebook! [Heritage & Historic Preservation - NPS](#)
Follow us on Twitter: [@HHPreservItNPS](#)

Re_ An Invitation from the Trump Family(4).pdf

From: [Stephanie Toothman](#)
To: [Goeken, Brian](#)
Cc: [Shireen Cohen](#)
Subject: Re: An Invitation from the Trump Family
Date: Monday, July 14, 2014 5:47:07 PM

Unfortunately I will be out of town but I will check on Peggy's schedule.

Sent from my iPad

On Jul 14, 2014, at 3:56 PM, "Goeken, Brian" <brian_goeken@nps.gov> wrote:

Shireen,
Can you please send invitations to the National Park Service's Peggy O'Dell, Deputy Director of Operations, and Stephanie Toothman, Associate Director of Cultural Resources, Partnerships and Science? Their email addresses are as follows:

peggy_o'dell@nps.gov
stephanie_toothman@nps.gov

Thanks,
Brian

On Mon, Jul 14, 2014 at 3:27 PM, Goeken, Brian <brian_goeken@nps.gov> wrote:

thanks, Shireen. much appreciated.

On Mon, Jul 14, 2014 at 1:58 PM, Shireen Cohen <scohen@trumporg.com> wrote:

Hi Brian,

I hope this email finds you well and you had a fantastic weekend!

As of now we have invited Audrey Tepper, John Sandor, Peter May, Brian Woodbury, Robert Vogel, Steve Lorenzetti, Jon Jarvis, Robin Nixon and Carol Richard from the National Park Service. If you would like us to extend an invite to anyone else from the department we'd be happy to send along!

Best,

Shireen

<image001.png>

Shireen Cohen
Marketing Coordinator

725 Fifth Avenue | New York, NY | 10022
p. 212.715.6787

scohen@trumporg.com | trump.com

From: Goeken, Brian [mailto:brian_goeken@nps.gov]
Sent: Friday, July 11, 2014 5:16 PM
To: Shireen Cohen
Subject: Re: An Invitation from the Trump Family

Shireen,

Yes, I will be attending.

Also, are you able to tell me who else from the National Park Service or the Department of the Interior has been invited? If it was sent by email, I can make sure that they got it.

Thanks,

Brian

Brian Goeken, AICP

Chief, Technical Preservation Services

National Park Service

On Thu, Jul 10, 2014 at 5:30 PM, Shireen Cohen <scohen@trumporg.com> wrote:

[<image002.jpg>](#)

This e-mail message, and any attachments to it, are for the sole use of the intended recipients, and may contain confidential and privileged information. Any unauthorized review, use, disclosure or distribution of this email message or its attachments is prohibited. If you are not the intended recipient, please contact the sender by reply email and destroy all copies of the original message. Please note that any views or opinions presented in this email are solely those of the author and do not necessarily represent those of the company. Finally, while the company uses virus protection, the recipient should check this email and any attachments for the presence of viruses. The company accepts no liability for any damage caused by any virus transmitted by this email.

--

Brian Goeken, AICP

Chief, Technical Preservation Services

National Park Service

Mail:

1849 C Street NW - Org code 2255

Washington, DC 20240

Overnight delivery:

1201 'Eye' Street NW

Floor 6-015

Washington, DC 20005

202-354-2033 phone

202-371-1616 fax

Brian_Goeken@nps.gov

Website: www.nps.gov/tps

Like us on facebook! [Heritage & Historic Preservation - NPS](#)

Follow us on Twitter: [@HHPreservItNPS](#)

--

Brian Goeken, AICP
Chief, Technical Preservation Services
National Park Service

Mail:
1849 C Street NW - Org code 2255
Washington, DC 20240

Overnight delivery:
1201 'Eye' Street NW
Floor 6-015
Washington, DC 20005

202-354-2033 phone
202-371-1616 fax
Brian_Goeken@nps.gov

Website: www.nps.gov/tps
Like us on facebook! [Heritage & Historic Preservation - NPS](#)
Follow us on Twitter: [@HHPreservItNPS](#)

--

Brian Goeken, AICP
Chief, Technical Preservation Services
National Park Service

Mail:
1849 C Street NW - Org code 2255
Washington, DC 20240

Overnight delivery:
1201 'Eye' Street NW
Floor 6-015
Washington, DC 20005

202-354-2033 phone

202-371-1616 fax

Brian_Goeken@nps.gov

Website: www.nps.gov/tps

Like us on facebook! [Heritage & Historic Preservation - NPS](#)

Follow us on Twitter: [@HHPreservItNPS](#)

Re_ An Invitation from the Trump Family(5).pdf

From: [May, Peter](#)
To: [Shireen Cohen](#)
Subject: Re: An Invitation from the Trump Family
Date: Tuesday, July 15, 2014 6:24:09 AM

Thank you. I will plan to attend.

Peter May
Associate Regional Director - Lands, Planning, and Design
National Park Service - National Capital Region
1100 Ohio Drive SW, Washington, DC 20242
(202) 619 7025
pmay@nps.gov

On Mon, Jul 14, 2014 at 5:27 PM, Shireen Cohen <scohen@trumporg.com> wrote:

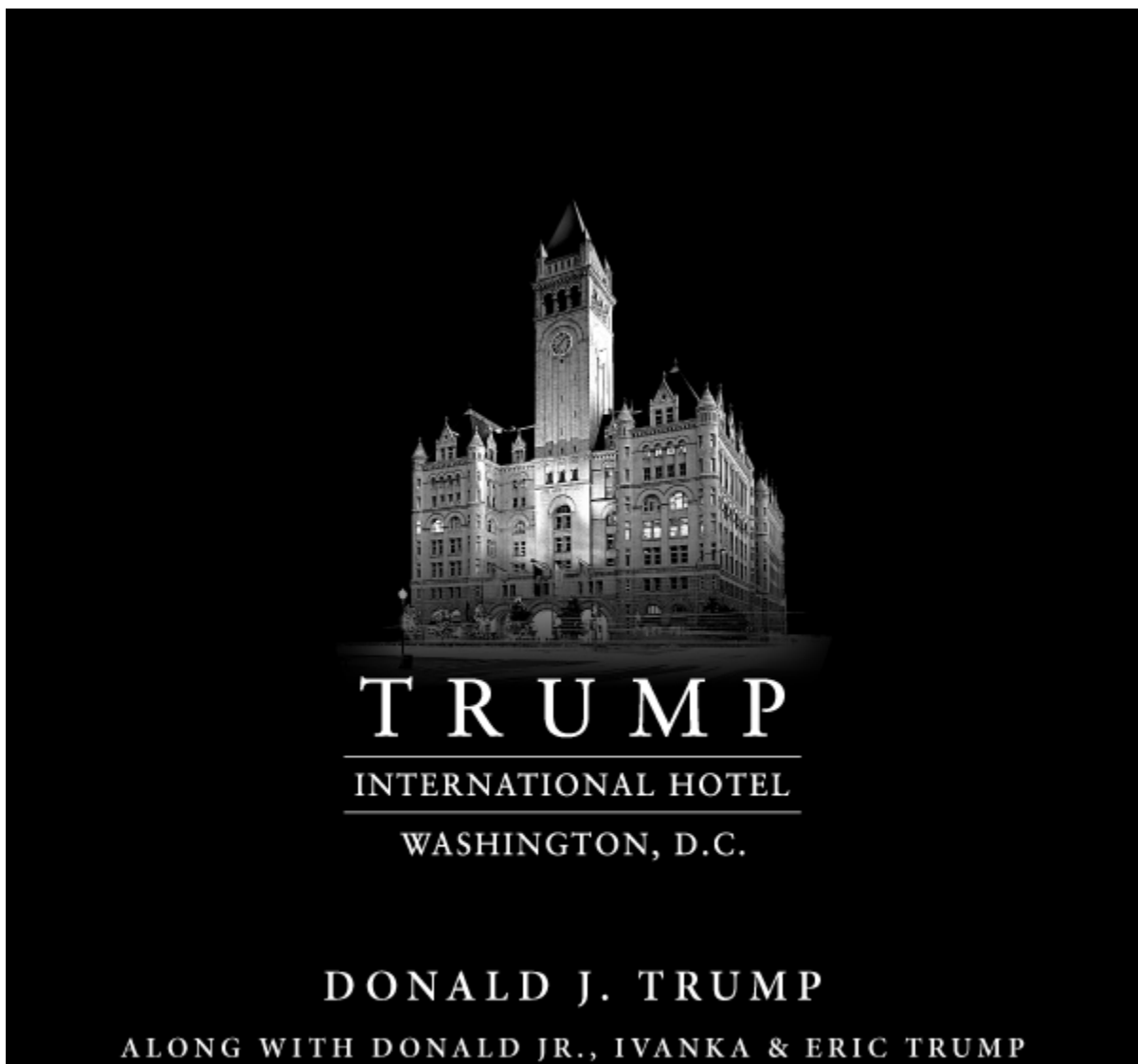

*Invite you to celebrate the commencement of construction of the
Trump International Hotel, Washington D.C.*

WEDNESDAY, JULY 23, 2014
10:00 AM

THE OLD POST OFFICE
1100 PENNSYLVANIA AVENUE NW
OUTDOOR MAIN STEPS

*RSVP by July 18 to
scohen@trumporg.com*

This e-mail message, and any attachments to it, are for the sole use of the intended recipients, and may contain confidential and privileged information. Any unauthorized review, use, disclosure or distribution of this email message or its attachments is prohibited. If you are not the intended recipient, please contact the sender by reply email and destroy all copies of the original message. Please note that any views or opinions presented in this email are solely those of the author and do not necessarily represent those of the company. Finally, while the company uses virus protection, the recipient should check this email and any attachments for the presence of viruses. The company accepts no liability for any damage caused by any virus transmitted by this email.

Re_ An Invitation from the Trump Family(6).pdf

From: claire_rozdilski@nps.gov on behalf of [O'Dell, Margaret](#)
To: [Shireen Cohen](#)
Subject: Re: An Invitation from the Trump Family
Date: Friday, July 18, 2014 7:58:26 AM

I'm so sorry, but I will no longer be able to attend. Thank you for the invitation and best wishes for a successful event!

On Tue, Jul 15, 2014 at 7:59 AM, O'Dell, Margaret <peggy_o'dell@nps.gov> wrote:
Thank you for the invitation. I would be happy to attend.

On Mon, Jul 14, 2014 at 4:02 PM, Shireen Cohen <scohen@trumporg.com> wrote:

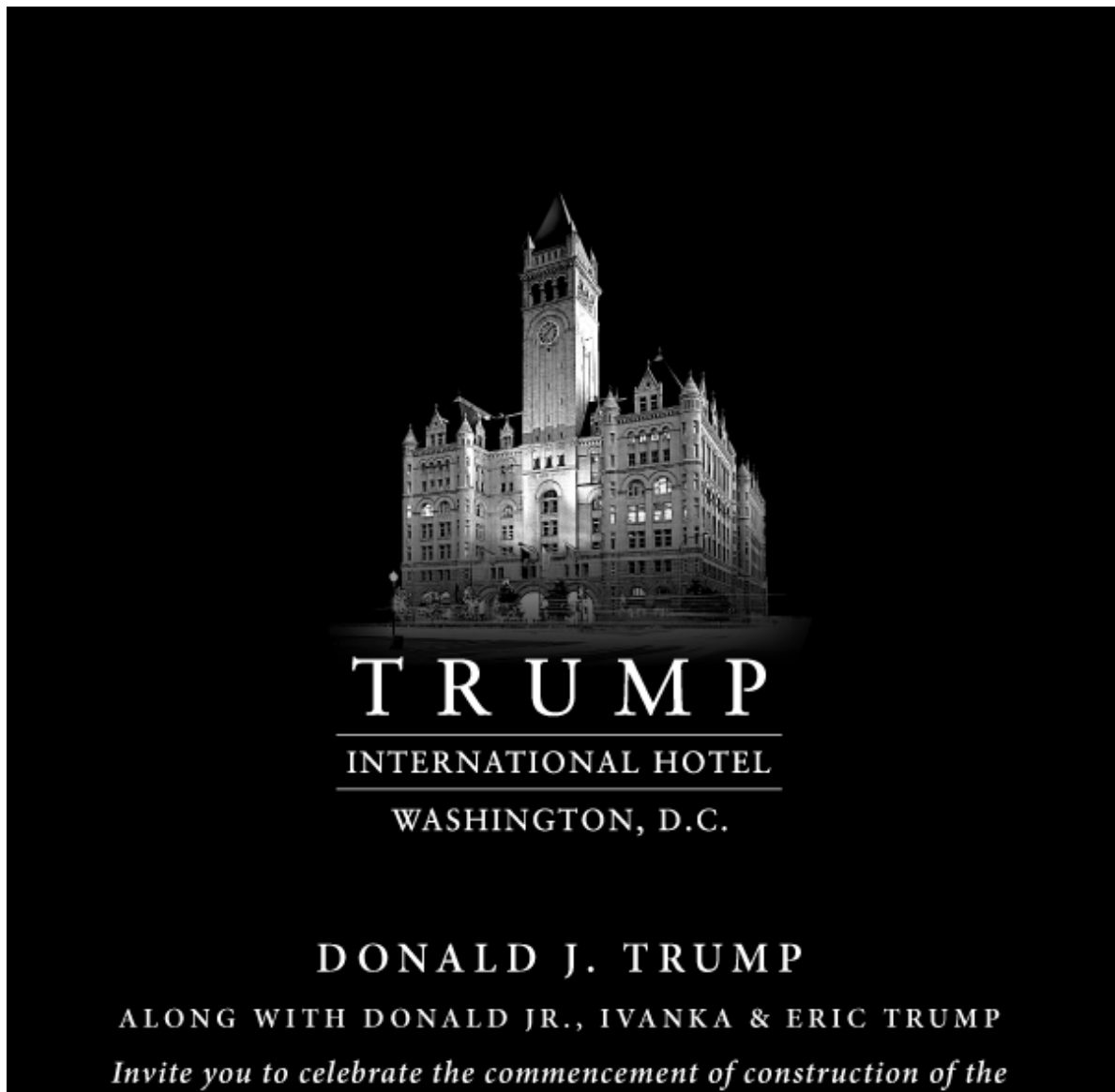

Trump International Hotel, Washington D.C.

WEDNESDAY, JULY 23, 2014
10:00 AM

THE OLD POST OFFICE
1100 PENNSYLVANIA AVENUE NW
OUTDOOR MAIN STEPS

*RSVP by July 18 to
scohen@trumporg.com*

This e-mail message, and any attachments to it, are for the sole use of the intended recipients, and may contain confidential and privileged information. Any unauthorized review, use, disclosure or distribution of this email message or its attachments is prohibited. If you are not the intended recipient, please contact the sender by reply email and destroy all copies of the original message. Please note that any views or opinions presented in this email are solely those of the author and do not necessarily represent those of the company. Finally, while the company uses virus protection, the recipient should check this email and any attachments for the presence of viruses. The company accepts no liability for any damage caused by any virus transmitted by this email.

Re_ An Invitation from the Trump Family(7).pdf

From: [Woodbury, Brian](#)
To: [Shireen Cohen](#)
Subject: Re: An Invitation from the Trump Family
Date: Friday, July 18, 2014 9:56:54 AM

Shireen,

I hope you are having a great day. I will be in attendance. My apologies for just getting back to you.

Kind regards,

Brian

On Thu, Jul 10, 2014 at 5:30 PM, Shireen Cohen <scohen@trumporg.com> wrote:

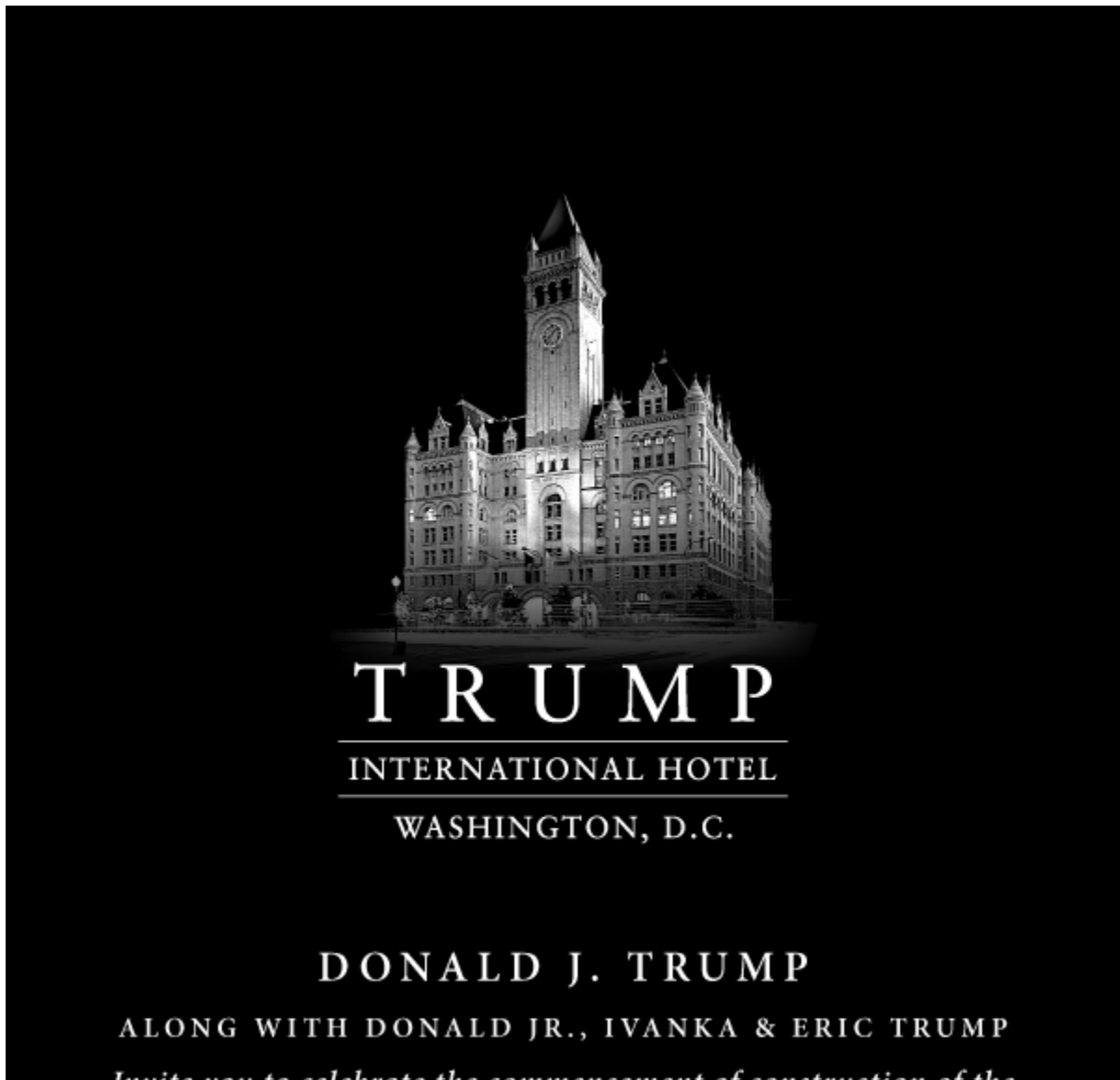

*Invite you to celebrate the commencement of construction of the
Trump International Hotel, Washington D.C.*

WEDNESDAY, JULY 23, 2014
10:00 AM

THE OLD POST OFFICE
1100 PENNSYLVANIA AVENUE NW
OUTDOOR MAIN STEPS

*RSVP by July 18 to
scohen@trumporg.com*

This e-mail message, and any attachments to it, are for the sole use of the intended recipients, and may contain confidential and privileged information. Any unauthorized review, use, disclosure or distribution of this email message or its attachments is prohibited. If you are not the intended recipient, please contact the sender by reply email and destroy all copies of the original message. Please note that any views or opinions presented in this email are solely those of the author and do not necessarily represent those of the company. Finally, while the company uses virus protection, the recipient should check this email and any attachments for the presence of viruses. The company accepts no liability for any damage caused by any virus transmitted by this email.

--

Brian M. Woodbury
Chief of Lands
National Park Service - National Capital Region
1100 Ohio Drive, SW
Washington, DC 20242
(202) 619.7034
brian_woodbury@nps.gov

RSVP(1).pdf

From: [Richard, Carolyn](#)
To: scohen@trumporg.com
Subject: RSVP
Date: Friday, July 18, 2014 11:20:48 AM

Hello Ms. Cohen,

Yes, I will be attending the event. Thank you for the invitation.

Carolyn Richard
Chief of Interpretation and Education
National Mall and Memorial Parks
900 Ohio Drive, S.W.
Washington, D.C. 20024
Phone: (202) 245-4682
<http://www.nps.gov/nama>

Robin Nixon will be attending as well..pdf

From: [Richard, Carolyn](#)
To: scohen@trumporg.com
Subject: Robin Nixon will be attending as well.
Date: Friday, July 18, 2014 12:42:48 PM

I'm not sure if you've been told through another source, but our Chief of Partnerships, Robin Nixon, will also be attending.

Thank you,
Carolyn Richard
Chief of Interpretation and Education
National Mall and Memorial Parks
900 Ohio Drive, S.W.
Washington, D.C. 20024
Phone: (202) 245-4682
<http://www.nps.gov/nama>

Re_ An Invitation from the Trump Family(8).pdf

From: [Keller, Jamie](#)
To: [Shireen Cohen](#)
Subject: Re: An Invitation from the Trump Family
Date: Friday, July 18, 2014 2:51:52 PM

I plan on attending, barring unforeseen developments.

Jamie Keller
Supervisory Park Ranger
National Mall and Memorial Parks
(Cell) 202-505-0674

On Fri, Jul 18, 2014 at 4:12 PM, Shireen Cohen <scohen@trumporg.com> wrote:

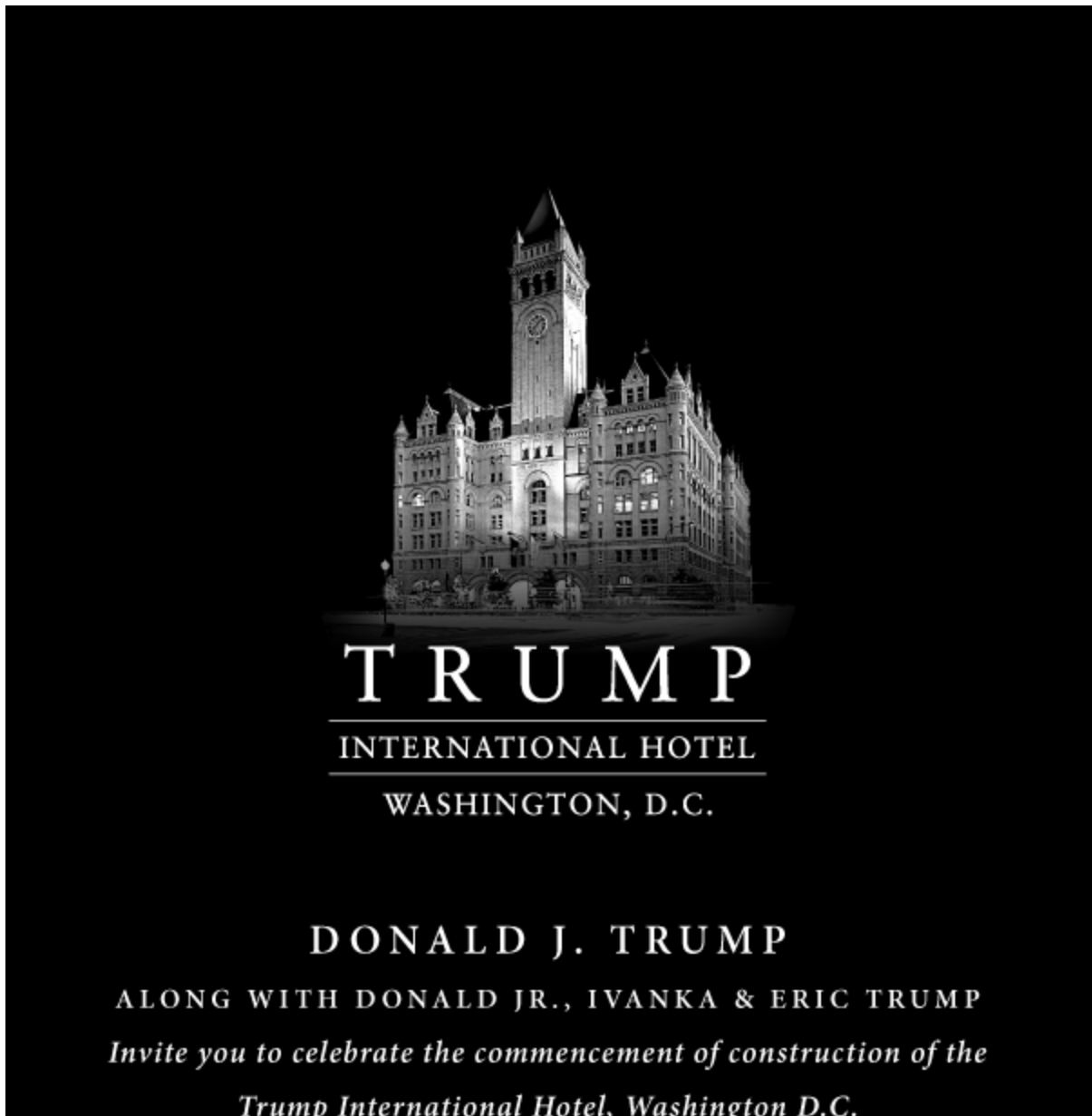

WEDNESDAY, JULY 23, 2014
10:00 AM

THE OLD POST OFFICE
1100 PENNSYLVANIA AVENUE NW
OUTDOOR MAIN STEPS

RSVP to scohen@trumporg.com

This e-mail message, and any attachments to it, are for the sole use of the intended recipients, and may contain confidential and privileged information. Any unauthorized review, use, disclosure or distribution of this email message or its attachments is prohibited. If you are not the intended recipient, please contact the sender by reply email and destroy all copies of the original message. Please note that any views or opinions presented in this email are solely those of the author and do not necessarily represent those of the company. Finally, while the company uses virus protection, the recipient should check this email and any attachments for the presence of viruses. The company accepts no liability for any damage caused by any virus transmitted by this email.

Re_ An Invitation from the Trump Family(9).pdf

From: [Sandor, John](#)
To: [Shireen Cohen](#)
Subject: Re: An Invitation from the Trump Family
Date: Monday, July 21, 2014 7:56:54 AM

Thank you very much for including me in the invitation, but I will be unable to attend.

John Sandor
Technical Preservation Services
202-354-2030

On Fri, Jul 18, 2014 at 4:12 PM, Shireen Cohen <scohen@trumporg.com> wrote:



TRUMP
INTERNATIONAL HOTEL
WASHINGTON, D.C.

DONALD J. TRUMP
ALONG WITH DONALD JR., IVANKA & ERIC TRUMP
*Invite you to celebrate the commencement of construction of the
Trump International Hotel, Washington D.C.*

WEDNESDAY, JULY 23, 2014

10:00 AM

THE OLD POST OFFICE
1100 PENNSYLVANIA AVENUE NW
OUTDOOR MAIN STEPS

RSVP to scohen@trumporg.com

This e-mail message, and any attachments to it, are for the sole use of the intended recipients, and may contain confidential and privileged information. Any unauthorized review, use, disclosure or distribution of this email message or its attachments is prohibited. If you are not the intended recipient, please contact the sender by reply email and destroy all copies of the original message. Please note that any views or opinions presented in this email are solely those of the author and do not necessarily represent those of the company. Finally, while the company uses virus protection, the recipient should check this email and any attachments for the presence of viruses. The company accepts no liability for any damage caused by any virus transmitted by this email.

Updated Cortile Rendering and Plan.pdf

From: [David Orowitz](#)
To: [Tepper, Audrey](#)
Subject: Updated Cortile Rendering and Plan
Date: Monday, July 21, 2014 1:18:00 PM
Attachments: [Cortile FF&FC Plan_Color.pdf](#)

Audrey,

Hope all is well. I am excited to share with you the updated plan and rendering for the cortile. We think that it greatly simplifies the space (removal of the fountain, less types of lighting, straight lines). We also think it looks really good.

I wanted to share as we thought that – though our previous design had been approved – there was the perspective that it could be improved upon.

I will give you a call now to discuss (as well as discuss next steps on the resubmittal).

Best,
Dave

David Orowitz

Senior Vice President, Acquisitions and Development
The Trump Organization
725 Fifth Avenue | New York, NY | 10022
p. 212.836.3252 | m. 646.315.4698 | f. 212.836.3202
dorowitz@trumporg.com | trump.com

This e-mail message, and any attachments to it, are for the sole use of the intended recipients, and may contain confidential and privileged information. Any unauthorized review, use, disclosure or distribution of this email message or its attachments is prohibited. If you are not the intended recipient, please contact the sender by reply email and destroy all copies of the original message. Please note that any views or opinions presented in this email are solely those of the author and do not necessarily represent those of the company. Finally, while the company uses virus protection, the recipient should check this email and any attachments for the presence of viruses. The company accepts no liability for any damage caused by any virus transmitted by this email.

Cortile FF&FC Plan_Color.pdf



TENANT #4
± 190 SF
N.I.C.

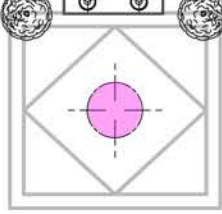
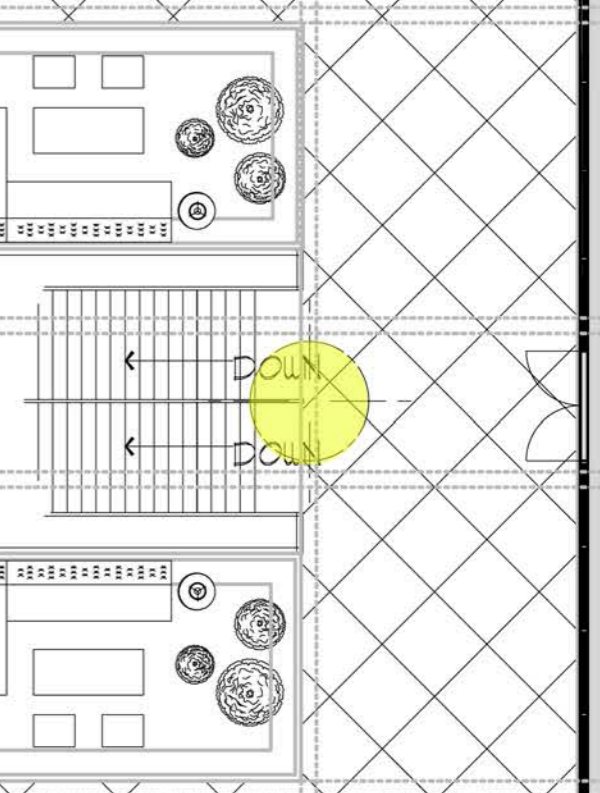
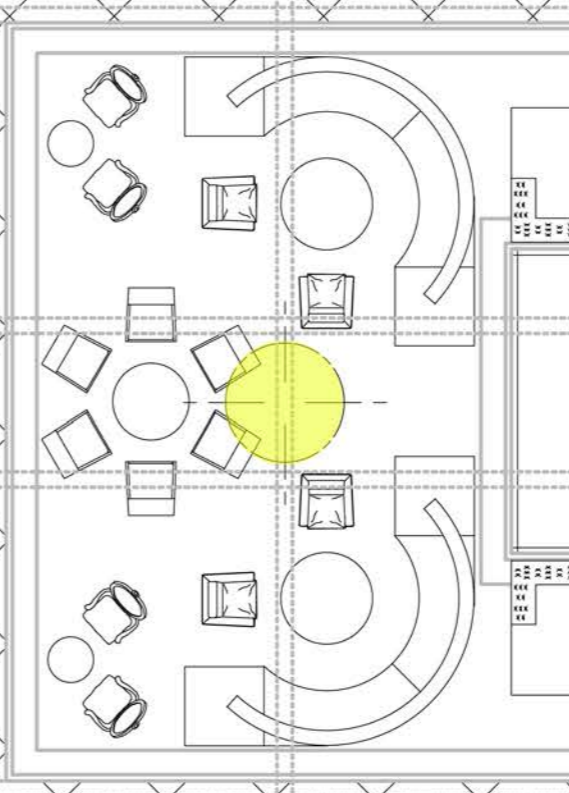
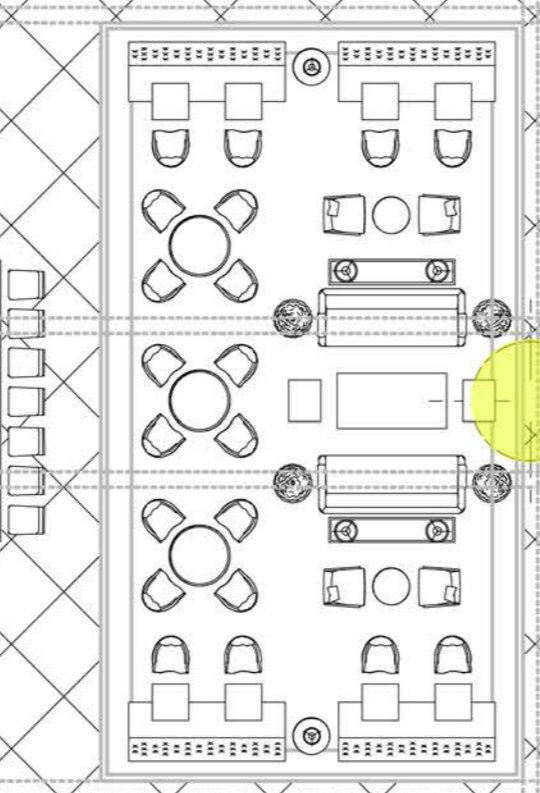
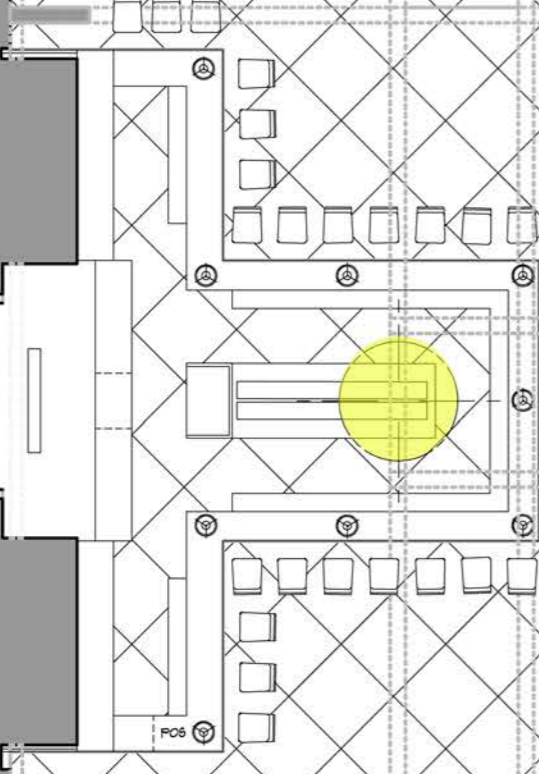
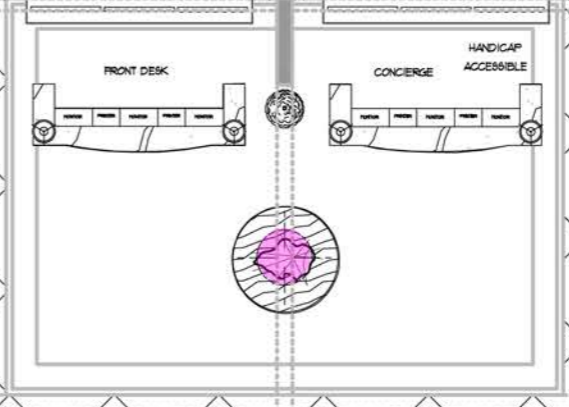
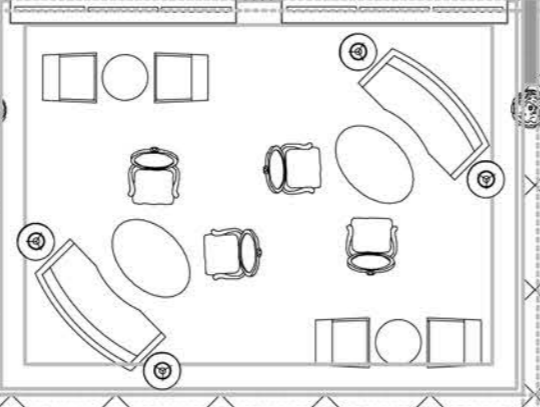
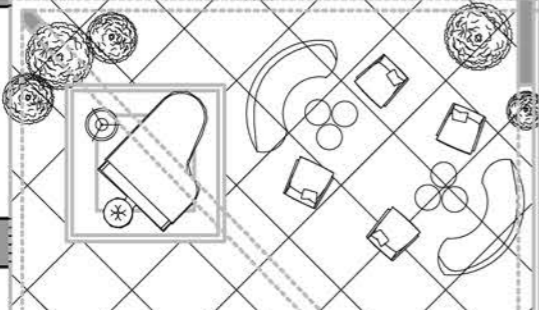
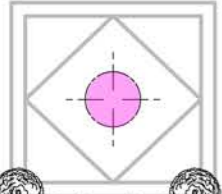

TENANT #5
± 205 SF
N.I.C.

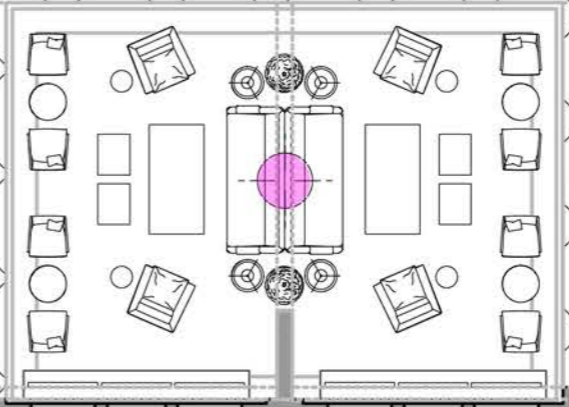
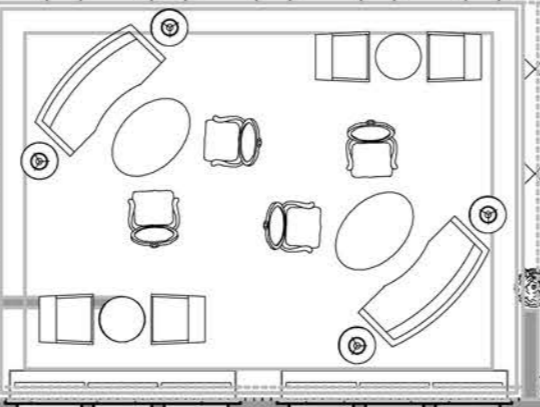
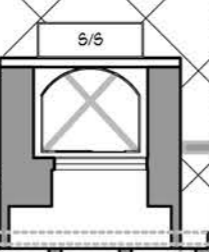
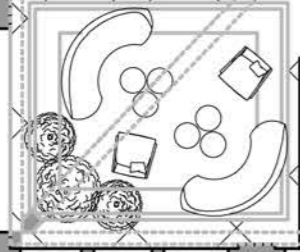

2
2D
2D

Re_ An Invitation from the Trump Family(10).pdf

From: [Nixon, Robin](#)
To: [Shireen Cohen](#)
Subject: Re: An Invitation from the Trump Family
Date: Tuesday, July 22, 2014 6:25:42 AM

Ms. Cohen, I am sorry not to have replied sooner, but I have just been assigned, along with one of my colleagues, to represent the National Park Service, National Mall and Memorial Parks, at your event. Attending will be:

Robin Nixon, Chief of Partnerships
Carolyn Richard, Chief of Interpretation and Education

Thanks!! Robin

Robin Nixon
Chief of Partnerships
National Mall and Memorial Parks
National Park Service
900 Ohio Drive, SW
Washington, DC 20024
202-245-4710 (ofc)
202-738-7956 (cell)
robin_nixon@nps.gov

On Thu, Jul 10, 2014 at 5:30 PM, Shireen Cohen <scohen@trumporg.com> wrote:

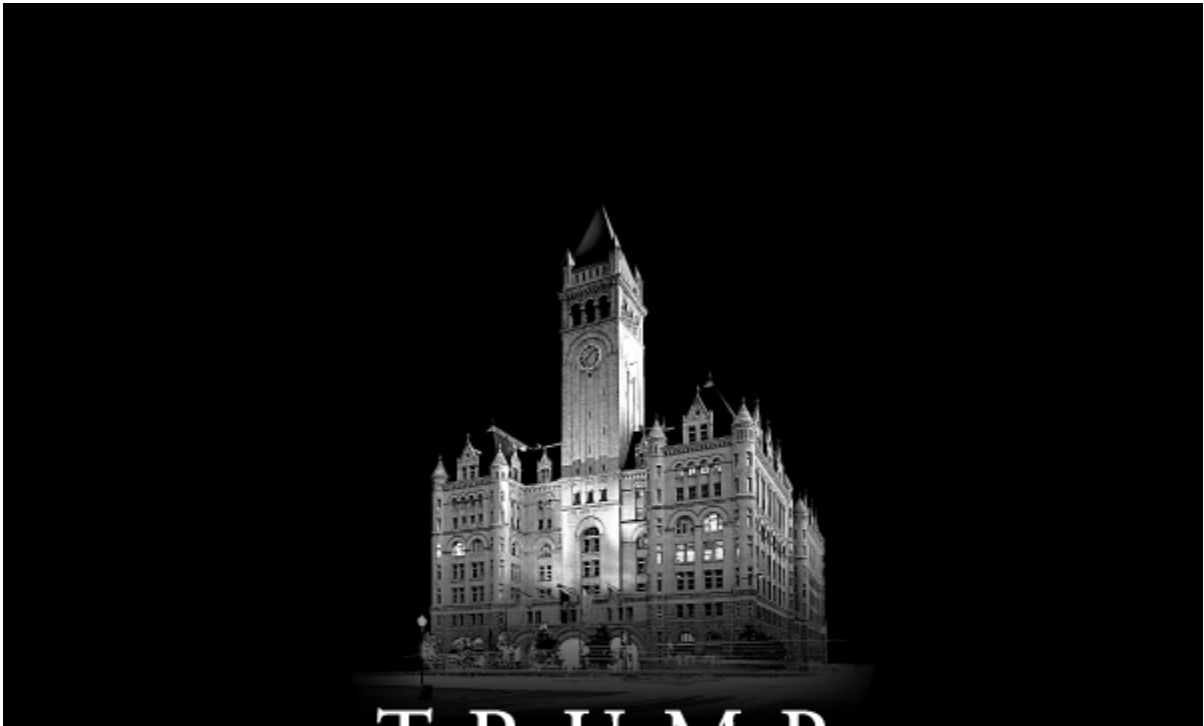

T R U M P
INTERNATIONAL HOTEL
WASHINGTON, D.C.

DONALD J. TRUMP

ALONG WITH DONALD JR., IVANKA & ERIC TRUMP

*Invite you to celebrate the commencement of construction of the
Trump International Hotel, Washington D.C.*

**WEDNESDAY, JULY 23, 2014
10:00 AM**

**THE OLD POST OFFICE
1100 PENNSYLVANIA AVENUE NW
OUTDOOR MAIN STEPS**

*RSVP by July 18 to
scohen@trumporg.com*

This e-mail message, and any attachments to it, are for the sole use of the intended recipients, and may contain confidential and privileged information. Any unauthorized review, use, disclosure or distribution of this email message or its attachments is prohibited. If you are not the intended recipient, please contact the sender by reply email and destroy all copies of the original message. Please note that any views or opinions presented in this email are solely those of the author and do not necessarily represent those of the company. Finally, while the company uses virus protection, the recipient should check this email and any attachments for the presence of viruses. The company accepts no liability for any damage caused by any virus transmitted by this email.

Revisions to the OPO Cortile.pdf

From: [Tepper, Audrey](#)
To: [David Orowitz](#)
Cc: [Hany Hassan](#); [Andrew Lewis](#)
Subject: Revisions to the OPO Cortile
Date: Tuesday, July 22, 2014 6:58:58 AM

David:

Thank you for calling yesterday and for forwarding the revised design of the OPO Cortile. After we spoke, I sent your e-mail to Andrew Lewis, together with a synopsis of our conversation. Below is his response on the matter. All is well in this department, which is good:

"Audrey:

I was not in the office yesterday but thanks for the voice and email messages. I agree with you that the elimination of the fountain and the general simplification of the overall design scheme for the Cortile is appropriate. "

See you tomorrow,

Audrey T. Tepper - LEED Green Associate
Historical Architect
National Park Service
Technical Preservation Services Branch
1201 Eye Street, NW - Org. 2200
Washington, DC 20005
202-354-2027
202-371-1616 (FAX)
audrey_tepper@nps.gov

RE_ Revisions to the OPO Cortile.pdf

From: [David Orowitz](#)
To: [Tepper, Audrey](#)
Cc: [Hany Hassan](#); [Andrew Lewis](#)
Subject: RE: Revisions to the OPO Cortile
Date: Tuesday, July 22, 2014 7:43:20 AM

Thanks, Audrey and Andy. We are glad everyone agrees that this is an improvement. We think it looks a lot better as well.

David Orowitz

Senior Vice President, Acquisitions and Development
The Trump Organization
725 Fifth Avenue | New York, NY | 10022
p. 212.836.3252 | m. 646.315.4698 | f. 212.836.3202
dorowitz@trumporg.com | trump.com

From: Tepper, Audrey [mailto:audrey_tepper@nps.gov]
Sent: Tuesday, July 22, 2014 8:59 AM
To: David Orowitz
Cc: Hany Hassan; Andrew Lewis
Subject: Revisions to the OPO Cortile

David:

Thank you for calling yesterday and for forwarding the revised design of the OPO Cortile. After we spoke, I sent your e-mail to Andrew Lewis, together with a synopsis of our conversation. Below is his response on the matter. All is well in this department, which is good:

"Audrey:

I was not in the office yesterday but thanks for the voice and email messages. I agree with you that the elimination of the fountain and the general simplification of the overall design scheme for the Cortile is appropriate. "

See you tomorrow,

Audrey T. Tepper - LEED Green Associate
Historical Architect
National Park Service
Technical Preservation Services Branch
1201 Eye Street, NW - Org. 2200
Washington, DC 20005
202-354-2027
202-371-1616 (FAX)
audrey_tepper@nps.gov

This e-mail message, and any attachments to it, are for the sole use of the intended recipients, and may contain confidential and privileged information. Any unauthorized review, use, disclosure or distribution of this email message or its attachments is prohibited. If you are not the intended recipient, please contact the sender by reply email and destroy all copies of the original message. Please note that any views or opinions presented in this email are solely

those of the author and do not necessarily represent those of the company. Finally, while the company uses virus protection, the recipient should check this email and any attachments for the presence of viruses. The company accepts no liability for any damage caused by any virus transmitted by this email.

Can't download the files you sent....pdf

From: [Tepper, Audrey](#)
To: [Hany Hassan](#); [David Orowitz](#)
Cc: [Andrew Lewis](#)
Subject: Can't download the files you sent...
Date: Wednesday, July 23, 2014 9:55:10 AM

Hany and David:

Nice ceremony today! Thank goodness the seating area quickly became shaded and water was provided.

Unfortunately, because of security restrictions here at NPS, I was unable to download the files you sent. Can I get them on a disk or flash drive instead? You can also take the old fashioned route and get me hard copies, which actually, given my packed schedule these days, might be the best course of action.

When Andrew and I have a chance to look at what you forwarded, I'm sure we'll schedule a meeting.

Hope to see you soon and here's to future collaboration,

--

Audrey T. Tepper - LEED Green Associate
Historical Architect
National Park Service
Technical Preservation Services Branch
1201 Eye Street, NW - Org. 2200
Washington, DC 20005
202-354-2027
202-371-1616 (FAX)
audrey_tepper@nps.gov

Re_ Can't download the files you sent....pdf

From: [Tepper, Audrey](#)
To: [Hany Hassan](#)
Cc: [David Orowitz](#); [Andrew Lewis](#); [Rence Gill](#)
Subject: Re: Can't download the files you sent...
Date: Wednesday, July 23, 2014 10:00:00 AM

That's great. Thanks mucho.

On Wed, Jul 23, 2014 at 11:57 AM, Hany Hassan <hhassan@bbbarch.com> wrote:

Audrey, Andy:

We will send you 2 hard copies.

Hany

Hany Hassan FAIA
Partner

Beyer Blinder Belle
Architects & Planners LLP
3307 M Street, NW, Suite 301
Washington, DC 20007
[202-333-8000](tel:202-333-8000)
[202 333 8843](tel:202-333-8843) fax
hhassan@bbbarch.com
www.beyerblinderbelle.com

The above e-mail is for the intended recipient only, and may contain information that is privileged, confidential, or otherwise protected from disclosure. If you are not the intended recipient, please advise the sender immediately. Nothing in this e-mail or any attachments to this e-mail grants any license or transfers any ownership to the contents of the e-mail or attachments or any intellectual property rights contained therein. Unauthorized use or distribution is prohibited and may be unlawful. Beyer Blinder Belle Architects Planners LLP accepts no responsibility for any loss or damage from the use of this message and/or any attachments including damage from viruses.

On Jul 23, 2014, at 11:55 AM, "Tepper, Audrey" <audrey_tepper@nps.gov> wrote:

Hany and David:

Nice ceremony today! Thank goodness the seating area quickly became shaded and water was provided.

Unfortunately, because of security restrictions here at NPS, I was unable to download the files you sent. Can I get them on a disk or flash drive instead? You can also take the old fashioned route and get me hard copies, which actually, given my packed schedule these days, might be the best course of

action.

When Andrew and I have a chance to look at what you forwarded, I'm sure we'll schedule a meeting.

Hope to see you soon and here's to future collaboration,

--

Audrey T. Tepper - LEED Green Associate
Historical Architect
National Park Service
Technical Preservation Services Branch
1201 Eye Street, NW - Org. 2200
Washington, DC 20005
202-354-2027
202-371-1616 (FAX)
audrey_tepper@nps.gov

--

Audrey T. Tepper - LEED Green Associate
Historical Architect
National Park Service
Technical Preservation Services Branch
1201 Eye Street, NW - Org. 2200
Washington, DC 20005
202-354-2027
202-371-1616 (FAX)
audrey_tepper@nps.gov

Monday.pdf

From: [David Orowitz](#)
To: [Tepper, Audrey](#)
Subject: Monday
Date: Monday, July 28, 2014 9:14:38 AM

Audrey,

Good news. Hany is able to do 1 p.m. on Monday. Please let us know if that works for Andy. Have a good conference.

Best,
Dave

David Orowitz
Senior Vice President, Acquisitions and Development
The Trump Organization
725 Fifth Avenue | New York, NY | 10022
p. 212.836.3252 | m. 646.315.4698 | f. 212.836.3202
dorowitz@trumporg.com | trump.com

This e-mail message, and any attachments to it, are for the sole use of the intended recipients, and may contain confidential and privileged information. Any unauthorized review, use, disclosure or distribution of this email message or its attachments is prohibited. If you are not the intended recipient, please contact the sender by reply email and destroy all copies of the original message. Please note that any views or opinions presented in this email are solely those of the author and do not necessarily represent those of the company. Finally, while the company uses virus protection, the recipient should check this email and any attachments for the presence of viruses. The company accepts no liability for any damage caused by any virus transmitted by this email.

OPO Meeting.pdf

From: [Tepper, Audrey](#)
To: [David Orowitz](#); [Hany Hassan](#); [Andrew Lewis](#)
Subject: OPO Meeting
Date: Monday, July 28, 2014 12:47:32 PM

Gents:

I touched base with Andrew regarding a meeting on the afternoon of August 4. Unfortunately, Andrew is not available at all that day. Can we come up with another time?

I am available:
8/5 - not available
8/6 - afternoon
8/7 - all day
8/8 - not available

--

Audrey T. Tepper - LEED Green Associate
Historical Architect
National Park Service
Technical Preservation Services Branch
1201 Eye Street, NW - Org. 2200
Washington, DC 20005
202-354-2027
202-371-1616 (FAX)
audrey_tepper@nps.gov

RE_ OPO Meeting.pdf

From: [David Orowitz](#)
To: [Lewis, Andrew \(OP\)](#); [Tepper, Audrey](#); [Hany Hassan](#)
Subject: RE: OPO Meeting
Date: Monday, July 28, 2014 2:45:07 PM

All,

We were really hoping to have this meeting this week, but understand from Audrey that is not possible. Pushing this to Thursday is very problematic for the project as we are ready to start construction this week and can begin as soon as we have this meeting and resolve the last couple of outstanding issues. Is there any way that we can have a brief meeting earlier (as late as next Monday) and then have a longer sit down next Thursday?

Best,
Dave

David Orowitz
Senior Vice President, Acquisitions and Development
The Trump Organization
725 Fifth Avenue | New York, NY | 10022
p. 212.836.3252 | m. 646.315.4698 | f. 212.836.3202
dorowitz@trumporg.com | trump.com

From: Lewis, Andrew (OP) [<mailto:andrew.lewis@dc.gov>]
Sent: Monday, July 28, 2014 2:53 PM
To: Tepper, Audrey; David Orowitz; Hany Hassan
Subject: RE: OPO Meeting

Of the dates/times Audrey has suggested, I could be available on the morning of 8/7.

C. Andrew Lewis
Senior Historic Preservation Specialist
DC State Historic Preservation Office
Office of Planning
1100 4th Street, SW, Suite E650
Washington, DC 20024
Phone: 202-442-8841
Fax: 202-442-7638
andrew.lewis@dc.gov
www.planning.dc.gov/hpo

From: Tepper, Audrey [mailto:audrey_tepper@nps.gov]
Sent: Monday, July 28, 2014 2:48 PM
To: David Orowitz; Hany Hassan; Lewis, Andrew (OP)
Subject: OPO Meeting

Gents:

I touched base with Andrew regarding a meeting on the afternoon of August 4. Unfortunately,

Andrew is not available at all that day. Can we come up with another time?

I am available:

8/5 - not available

8/6 - afternoon

8/7 - all day

8/8 - not available

--

Audrey T. Tepper - LEED Green Associate

Historical Architect

National Park Service

Technical Preservation Services Branch

1201 Eye Street, NW - Org. 2200

Washington, DC 20005

202-354-2027

202-371-1616 (FAX)

audrey_tepper@nps.gov

This e-mail message, and any attachments to it, are for the sole use of the intended recipients, and may contain confidential and privileged information. Any unauthorized review, use, disclosure or distribution of this email message or its attachments is prohibited. If you are not the intended recipient, please contact the sender by reply email and destroy all copies of the original message. Please note that any views or opinions presented in this email are solely those of the author and do not necessarily represent those of the company. Finally, while the company uses virus protection, the recipient should check this email and any attachments for the presence of viruses. The company accepts no liability for any damage caused by any virus transmitted by this email.

OPO Meeting(1).pdf

From: [Tepper, Audrey](#)
To: [Hany Hassan](#); [David Orowitz](#); [Andrew Lewis](#)
Subject: OPO Meeting
Date: Monday, August 04, 2014 8:07:05 AM

Gents:

I'm writing to clarify that we will not meet today (8/4) on OPO. Andrew is unavailable, so it's best to put off this gathering until Thursday (8/7) so he can attend. I'm not sure if we figured out an exact time and place to meet. Should we meet on site again? If Andrew hasn't seen the model rooms, this makes sense, that is if it works on the Trump end.

Looking forward to seeing you all. The extension in time works better for me as well...due to my conference last week, I've not had time to look at what you sent.

--

Audrey T. Tepper - LEED Green Associate
Historical Architect
National Park Service
Technical Preservation Services Branch
1201 Eye Street, NW - Org. 2200
Washington, DC 20005
202-354-2027
202-371-1616 (FAX)
audrey_tepper@nps.gov

Trump Old Post Office - HTC Meeting.pdf

From: [David Orowitz](#)
To: [Hany Hassan \(hhassan@bbbarch.com\)](mailto:hhassan@bbbarch.com); [Tepper, Audrey](#); [Andrew Lewis](#)
Subject: Trump Old Post Office - HTC Meeting

This e-mail message, and any attachments to it, are for the sole use of the intended recipients, and may contain confidential and privileged information. Any unauthorized review, use, disclosure or distribution of this email message or its attachments is prohibited. If you are not the intended recipient, please contact the sender by reply email and destroy all copies of the original message. Please note that any views or opinions presented in this email are solely those of the author and do not necessarily represent those of the company. Finally, while the company uses virus protection, the recipient should check this email and any attachments for the presence of viruses. The company accepts no liability for any damage caused by any virus transmitted by this email.

RE_ OPO Meeting(1).pdf

From: [David Orowitz](#)
To: [Tepper, Audrey](#); [Hany Hassan](#); [Andrew Lewis](#)
Subject: RE: OPO Meeting
Date: Monday, August 04, 2014 8:51:40 AM

Audrey,

Can we plan to meet from 9 to 12 on Thursday? That would be great if you had already reviewed the materials in advance, so that we can leave that meeting with a clear path forward. We are ready to go.

Best,
Dave

David Orowitz
Senior Vice President, Acquisitions and Development
The Trump Organization
725 Fifth Avenue | New York, NY | 10022
p. 212.836.3252 | m. 646.315.4698 | f. 212.836.3202
dorowitz@trumporg.com | trump.com

From: Tepper, Audrey [mailto:audrey_tepper@nps.gov]
Sent: Monday, August 04, 2014 10:07 AM
To: Hany Hassan; David Orowitz; Andrew Lewis
Subject: OPO Meeting

Gents:

I'm writing to clarify that we will not meet today (8/4) on OPO. Andrew is unavailable, so it's best to put off this gathering until Thursday (8/7) so he can attend. I'm not sure if we figured out an exact time and place to meet. Should we meet on site again? If Andrew hasn't seen the model rooms, this makes sense, that is if it works on the Trump end.

Looking forward to seeing you all. The extension in time works better for me as well...due to my conference last week, I've not had time to look at what you sent.

--

Audrey T. Tepper - LEED Green Associate
Historical Architect
National Park Service
Technical Preservation Services Branch
1201 Eye Street, NW - Org. 2200
Washington, DC 20005
202-354-2027
202-371-1616 (FAX)
audrey_tepper@nps.gov

This e-mail message, and any attachments to it, are for the sole use of the intended recipients, and may contain confidential and privileged information. Any unauthorized review, use, disclosure or distribution of this email message or its attachments is prohibited. If you are not the intended recipient, please contact the sender by reply email and destroy all copies of the original message. Please note that any views or opinions presented in this email are solely

those of the author and do not necessarily represent those of the company. Finally, while the company uses virus protection, the recipient should check this email and any attachments for the presence of viruses. The company accepts no liability for any damage caused by any virus transmitted by this email.

Re_ OPO Meeting_1.pdf

From: [Tepper, Audrey](#)
To: [David Orowitz](#)
Subject: Re: OPO Meeting
Date: Monday, August 04, 2014 8:54:41 AM

This works well for me and I'll try my hardest to get to this review beforehand...gasp.

On Mon, Aug 4, 2014 at 10:51 AM, David Orowitz <dorowitz@trumporg.com> wrote:

Audrey,

Can we plan to meet from 9 to 12 on Thursday? That would be great if you had already reviewed the materials in advance, so that we can leave that meeting with a clear path forward. We are ready to go.

Best,

Dave

David Orowitz
Senior Vice President, Acquisitions and Development

The Trump Organization

725 Fifth Avenue | New York, NY | 10022
p. 212.836.3252 | m. 646.315.4698 | f. 212.836.3202

dorowitz@trumporg.com | trump.com

From: Tepper, Audrey [mailto:audrey_tepper@nps.gov]
Sent: Monday, August 04, 2014 10:07 AM
To: Hany Hassan; David Orowitz; Andrew Lewis
Subject: OPO Meeting

Gents:

I'm writing to clarify that we will not meet today (8/4) on OPO. Andrew is unavailable, so it's best to put off this gathering until Thursday (8/7) so he can attend. I'm not sure if we figured out an exact time and place to meet. Should we meet on site again? If Andrew hasn't seen the model rooms, this makes sense, that is if it works on the Trump end.

Looking forward to seeing you all. The extension in time works better for me as well...due to my conference last week, I've not had time to look at what you sent.

--

Audrey T. Tepper - LEED Green Associate

Historical Architect

National Park Service

Technical Preservation Services Branch

1201 Eye Street, NW - Org. 2200

Washington, DC 20005

202-354-2027

202-371-1616 (FAX)

audrey_tepper@nps.gov

This e-mail message, and any attachments to it, are for the sole use of the intended recipients, and may contain confidential and privileged information. Any unauthorized review, use, disclosure or distribution of this email message or its attachments is prohibited. If you are not the intended recipient, please contact the sender by reply email and destroy all copies of the original message. Please note that any views or opinions presented in this email are solely those of the author and do not necessarily represent those of the company. Finally, while the company uses virus protection, the recipient should check this email and any attachments for the presence of viruses. The company accepts no liability for any damage caused by any virus transmitted by this email.

--

Audrey T. Tepper - LEED Green Associate

Historical Architect

National Park Service

Technical Preservation Services Branch

1201 Eye Street, NW - Org. 2200

Washington, DC 20005

202-354-2027

202-371-1616 (FAX)

audrey_tepper@nps.gov

Accepted_ Trump Old Post Office - HTC Meeting @....pdf

From: [Google Calendar](#) on behalf of [Audrey Tepper](#)
To: [David Orowitz](#)
Subject: Accepted: Trump Old Post Office - HTC Meeting @ Thu Aug 7, 2014 9am - 12pm (Audrey Tepper)
Attachments: [invite.ics](#)

Audrey Tepper has accepted this invitation.
Trump Old Post Office - HTC Meeting

When Thu Aug 7, 2014 9am – 12pm Eastern Time
Where Old Post Office - Room 207 (HYPERLINK "<http://maps.google.com/maps?q=Old+Post+Office+-+Room+207&hl=en>" map)
Calendar Audrey Tepper
Who • David Orowitz - organizer
• Audrey Tepper - creator
• Hany Hassan (hhassan@bbbarch.com)
• Andrew Lewis

Invitation from HYPERLINK "<https://www.google.com/calendar/>" Google Calendar
You are receiving this courtesy email at the account dorowitz@trumporg.com because you are an attendee of this event.
To stop receiving future notifications for this event, decline this event. Alternatively you can sign up for a Google account at <https://www.google.com/calendar/> and control your notification settings for your entire calendar.

RE_ OPO Meeting(2).pdf

From: [David Orowitz](#)
To: [Tepper, Audrey](#)
Subject: RE: OPO Meeting
Date: Monday, August 04, 2014 9:09:47 AM

Thanks, Audrey.

David Orowitz
Senior Vice President, Acquisitions and Development
The Trump Organization
725 Fifth Avenue | New York, NY | 10022
p. 212.836.3252 | m. 646.315.4698 | f. 212.836.3202
dorowitz@trumporg.com | trump.com

From: Tepper, Audrey [mailto:audrey_tepper@nps.gov]
Sent: Monday, August 04, 2014 10:55 AM
To: David Orowitz
Subject: Re: OPO Meeting

This works well for me and I'll try my hardest to get to this review beforehand...gasp.

On Mon, Aug 4, 2014 at 10:51 AM, David Orowitz <dorowitz@trumporg.com> wrote:
Audrey,

Can we plan to meet from 9 to 12 on Thursday? That would be great if you had already reviewed the materials in advance, so that we can leave that meeting with a clear path forward. We are ready to go.

Best,
Dave

David Orowitz
Senior Vice President, Acquisitions and Development
The Trump Organization
725 Fifth Avenue | New York, NY | 10022
p. 212.836.3252 | m. 646.315.4698 | f. 212.836.3202
dorowitz@trumporg.com | trump.com

From: Tepper, Audrey [mailto:audrey_tepper@nps.gov]
Sent: Monday, August 04, 2014 10:07 AM
To: Hany Hassan; David Orowitz; Andrew Lewis
Subject: OPO Meeting

Gents:

I'm writing to clarify that we will not meet today (8/4) on OPO. Andrew is unavailable, so it's best to put off this gathering until Thursday (8/7) so he can attend. I'm not sure if we figured out an exact time and place to meet. Should we meet on site again? If Andrew hasn't seen the model rooms, this makes sense, that is if it works on the Trump end.

Looking forward to seeing you all. The extension in time works better for me as well...due to my conference last week, I've not had time to look at what you sent.

--

Audrey T. Tepper - LEED Green Associate
Historical Architect
National Park Service
Technical Preservation Services Branch
1201 Eye Street, NW - Org. 2200
Washington, DC 20005
202-354-2027
202-371-1616 (FAX)
audrey_tepper@nps.gov

This e-mail message, and any attachments to it, are for the sole use of the intended recipients, and may contain confidential and privileged information. Any unauthorized review, use, disclosure or distribution of this email message or its attachments is prohibited. If you are not the intended recipient, please contact the sender by reply email and destroy all copies of the original message. Please note that any views or opinions presented in this email are solely those of the author and do not necessarily represent those of the company. Finally, while the company uses virus protection, the recipient should check this email and any attachments for the presence of viruses. The company accepts no liability for any damage caused by any virus transmitted by this email.

--

Audrey T. Tepper - LEED Green Associate
Historical Architect
National Park Service
Technical Preservation Services Branch
1201 Eye Street, NW - Org. 2200
Washington, DC 20005
202-354-2027
202-371-1616 (FAX)
audrey_tepper@nps.gov

Re_ OPO Meeting(1)_1.pdf

From: [Tepper, Audrey](#)
To: [Hany Hassan](#)
Cc: [David Orowitz](#); [Andrew Lewis](#)
Subject: Re: OPO Meeting
Date: Monday, August 04, 2014 11:11:43 AM

Thanks Hany. Is Andrew available as well at that time?

On Mon, Aug 4, 2014 at 1:09 PM, Hany Hassan <hhassan@bbbarch.com> wrote:

All,

I have changed my schedule to attend at 9am. Hope this works for everyone.

Hany

Hany Hassan FAIA
Partner

Beyer Blinder Belle
Architects & Planners LLP
3307 M Street, NW, Suite 301
Washington, DC 20007
[202-333-8000](tel:202-333-8000)
[202 333 8843](tel:202-333-8843) fax
hhassan@bbbarch.com
www.beyerblinderbelle.com

The above e-mail is for the intended recipient only, and may contain information that is privileged, confidential, or otherwise protected from disclosure. If you are not the intended recipient, please advise the sender immediately. Nothing in this e-mail or any attachments to this e-mail grants any license or transfers any ownership to the contents of the e-mail or attachments or any intellectual property rights contained therein. Unauthorized use or distribution is prohibited and may be unlawful. Beyer Blinder Belle Architects Planners LLP accepts no responsibility for any loss or damage from the use of this message and/or any attachments including damage from viruses.

On Aug 4, 2014, at 11:11 AM, "Hany Hassan" <hhassan@bbbarch.com> wrote:

All, I have a meeting from 10 to 11:30. I can meet anytime noon on. Sorry for the inconvenience.

Hany Hassan FAIA
Partner

Beyer Blinder Belle
Architects & Planners LLP
3307 M Street, NW, Suite 301
Washington, DC 20007
[202-333-8000](tel:202-333-8000)

[202 333 8843](tel:2023338843) fax
hhassan@bbbarch.com
www.beyerblinderbelle.com

The above e-mail is for the intended recipient only, and may contain information that is privileged, confidential, or otherwise protected from disclosure. If you are not the intended recipient, please advise the sender immediately. Nothing in this e-mail or any attachments to this e-mail grants any license or transfers any ownership to the contents of the e-mail or attachments or any intellectual property rights contained therein. Unauthorized use or distribution is prohibited and may be unlawful. Beyer Blinder Belle Architects Planners LLP accepts no responsibility for any loss or damage from the use of this message and/or any attachments including damage from viruses.

On Aug 4, 2014, at 10:50 AM, "David Orowitz" <dorowitz@trumporg.com> wrote:

Audrey,

Can we plan to meet from 9 to 12 on Thursday? That would be great if you had already reviewed the materials in advance, so that we can leave that meeting with a clear path forward. We are ready to go.

Best,

Dave

David Orowitz
Senior Vice President, Acquisitions and Development

The Trump Organization

725 Fifth Avenue | New York, NY | 10022
p. 212.836.3252 | m. 646.315.4698 | f. 212.836.3202

dorowitz@trumporg.com | trump.com

From: Tepper, Audrey [mailto:audrey_tepper@nps.gov]
Sent: Monday, August 04, 2014 10:07 AM
To: Hany Hassan; David Orowitz; Andrew Lewis
Subject: OPO Meeting

Gents:

I'm writing to clarify that we will not meet today (8/4) on OPO.

Andrew is unavailable, so it's best to put off this gathering until Thursday (8/7) so he can attend. I'm not sure if we figured out an exact time and place to meet. Should we meet on site again? If Andrew hasn't seen the model rooms, this makes sense, that is if it works on the Trump end.

Looking forward to seeing you all. The extension in time works better for me as well...due to my conference last week, I've not had time to look at what you sent.

--

Audrey T. Tepper - LEED Green Associate

Historical Architect

National Park Service

Technical Preservation Services Branch

1201 Eye Street, NW - Org. 2200

Washington, DC 20005

202-354-2027

202-371-1616 (FAX)

audrey_tepper@nps.gov

This e-mail message, and any attachments to it, are for the sole use of the intended recipients, and may contain confidential and privileged information. Any unauthorized review, use, disclosure or distribution of this email message or its attachments is prohibited. If you are not the intended recipient, please contact the sender by reply email and destroy all copies of the original message. Please note that any views or opinions presented in this email are solely those of the author and do not necessarily represent those of the company. Finally, while the company uses virus protection, the recipient should check this email and any attachments for the presence of viruses. The company accepts no liability for any damage caused by any virus transmitted by this email.

--

Audrey T. Tepper - LEED Green Associate
Historical Architect
National Park Service
Technical Preservation Services Branch
1201 Eye Street, NW - Org. 2200
Washington, DC 20005
202-354-2027
202-371-1616 (FAX)
audrey_tepper@nps.gov

Follow-up.pdf

From: [David Orowitz](#)
To: [Tepper, Audrey](#)
Cc: [Hany Hassan \(hhassan@bbbarch.com\)](mailto:hhassan@bbbarch.com)
Subject: Follow-up
Date: Thursday, August 07, 2014 11:04:27 AM

Audrey,

Thanks for all of your time today. We are focused on getting back to you quickly with the amendment.

Best,
Dave

David Orowitz
Senior Vice President, Acquisitions and Development
The Trump Organization
725 Fifth Avenue | New York, NY | 10022
p. 212.836.3252 | m. 646.315.4698 | f. 212.836.3202
dorowitz@trumporg.com | trump.com

This e-mail message, and any attachments to it, are for the sole use of the intended recipients, and may contain confidential and privileged information. Any unauthorized review, use, disclosure or distribution of this email message or its attachments is prohibited. If you are not the intended recipient, please contact the sender by reply email and destroy all copies of the original message. Please note that any views or opinions presented in this email are solely those of the author and do not necessarily represent those of the company. Finally, while the company uses virus protection, the recipient should check this email and any attachments for the presence of viruses. The company accepts no liability for any damage caused by any virus transmitted by this email.

Re_Follow-up.pdf

From: [Tepper, Audrey](#)
To: [David Orowitz](#)
Cc: [Hany Hassan \(hhassan@bbbarch.com\)](mailto:hhassan@bbbarch.com)
Subject: Re: Follow-up
Date: Thursday, August 07, 2014 11:10:13 AM

Thanks David.

I wanted to let you know that when I returned to the office, there was a message from Nancy Witherell. She didn't leave details, but I assume she called about the storage of historic doors. Her ears must have been burning! In any case, I'll send her an e-mail that I got her message and that I have a pretty good idea what it's about.

I'm sure we'll be in touch in the near future. Travel safely to India.

Audrey

On Thu, Aug 7, 2014 at 1:03 PM, David Orowitz <dorowitz@trumporg.com> wrote:

Audrey,

Thanks for all of your time today. We are focused on getting back to you quickly with the amendment.

Best,

Dave

David Orowitz
Senior Vice President, Acquisitions and Development

The Trump Organization

725 Fifth Avenue | New York, NY | 10022
p. 212.836.3252 | m. 646.315.4698 | f. 212.836.3202

dorowitz@trumporg.com | trump.com

This e-mail message, and any attachments to it, are for the sole use of the intended recipients, and may contain confidential and privileged information. Any unauthorized review, use, disclosure or distribution of this email message or its attachments is prohibited. If you are not the intended recipient, please contact the sender by reply email and destroy all copies of the original message. Please note that any views or opinions presented in this email are solely those of the author and do not necessarily represent those of the company.

Finally, while the company uses virus protection, the recipient should check this email and any attachments for the presence of viruses. The company accepts no liability for any damage caused by any virus transmitted by this email.

--

Audrey T. Tepper - LEED Green Associate
Historical Architect
National Park Service
Technical Preservation Services Branch
1201 Eye Street, NW - Org. 2200
Washington, DC 20005
202-354-2027
202-371-1616 (FAX)
audrey_tepper@nps.gov

RE_Follow-up_1.pdf

From: [David Orowitz](#)
To: [Tepper, Audrey](#)
Cc: [Hany Hassan \(hhassan@bbbarch.com\)](mailto:hhassan@bbbarch.com)
Subject: RE: Follow-up
Date: Thursday, August 07, 2014 11:11:11 AM

Sounds good. I had not even contacted her yet.

David Orowitz

Senior Vice President, Acquisitions and Development
The Trump Organization
725 Fifth Avenue | New York, NY | 10022
p. 212.836.3252 | m. 646.315.4698 | f. 212.836.3202
dorowitz@trumporg.com | trump.com

From: Tepper, Audrey [mailto:audrey_tepper@nps.gov]
Sent: Thursday, August 07, 2014 1:10 PM
To: David Orowitz
Cc: Hany Hassan (hhassan@bbbarch.com)
Subject: Re: Follow-up

Thanks David.

I wanted to let you know that when I returned to the office, there was a message from Nancy Witherell. She didn't leave details, but I assume she called about the storage of historic doors. Her ears must have been burning! In any case, I'll send her an e-mail that I got her message and that I have a pretty good idea what it's about.

I'm sure we'll be in touch in the near future. Travel safely to India.

Audrey

On Thu, Aug 7, 2014 at 1:03 PM, David Orowitz <dorowitz@trumporg.com> wrote:
Audrey,

Thanks for all of your time today. We are focused on getting back to you quickly with the amendment.

Best,
Dave

David Orowitz

Senior Vice President, Acquisitions and Development
The Trump Organization
725 Fifth Avenue | New York, NY | 10022
p. 212.836.3252 | m. 646.315.4698 | f. 212.836.3202
dorowitz@trumporg.com | trump.com

This e-mail message, and any attachments to it, are for the sole use of the intended recipients, and may contain confidential and privileged information. Any unauthorized review, use, disclosure or distribution of this email message or its attachments is prohibited. If you are not the intended recipient, please contact the sender by reply email and destroy all copies of the original message. Please note that any views or opinions presented in this email are solely

those of the author and do not necessarily represent those of the company. Finally, while the company uses virus protection, the recipient should check this email and any attachments for the presence of viruses. The company accepts no liability for any damage caused by any virus transmitted by this email.

--

Audrey T. Tepper - LEED Green Associate
Historical Architect
National Park Service
Technical Preservation Services Branch
1201 Eye Street, NW - Org. 2200
Washington, DC 20005
202-354-2027
202-371-1616 (FAX)
audrey_tepper@nps.gov

Your message.pdf

From: [Tepper, Audrey](#)
To: [Nancy Witherell](#)
Cc: [David Orowitz](#)
Subject: Your message
Date: Thursday, August 07, 2014 11:16:06 AM

Nancy:

I got your message earlier today. Your ears must be burning because I met with David Orowitz and Hany Hasan this morning to go over OPO Part 2 issues. A topic of conversation was the storage of historic doors. I assume this is what you want to discuss? You mentioned you'd be out this afternoon, but I'm sure we can touch base in the near future. I am working tomorrow and all next week, but will be out after that from Aug. 18-26.

Hope all is well,

--

Audrey T. Tepper - LEED Green Associate
Historical Architect
National Park Service
Technical Preservation Services Branch
1201 Eye Street, NW - Org. 2200
Washington, DC 20005
202-354-2027
202-371-1616 (FAX)
audrey_tepper@nps.gov

Conditional Approval for OPO Amendment.pdf

From: [Tepper, Audrey](#)
To: [Ivanka Trump](#)
Cc: [David Orowitz](#); [Hany Hassan](#); [Andrew Lewis](#); [Brian Goeken](#)
Subject: Conditional Approval for OPO Amendment
Date: Thursday, August 14, 2014 10:37:56 AM
Attachments: [Scan 659.PDF](#)
[Scan 660.PDF](#)

Dear Ivanka:

Attached is the conditional approval for the first Old Post Office amendment. With regular collaboration of the project team, we thankfully have made our way down the list of outstanding issues. This resulted in only a few conditions this round, which I believe are not terribly controversial. FYI, unless otherwise noted, what you propose in this current amendment is acceptable and you may proceed with construction.

If you have questions, please feel free to get in touch any time. I will be on leave from 8/18-8/26, but Andrew Lewis may be available in my absence.

Sincerely,

Audrey T. Tepper - LEED Green Associate
Historical Architect
National Park Service
Technical Preservation Services Branch
1201 Eye Street, NW - Org. 2200
Washington, DC 20005
202-354-2027
202-371-1616 (FAX)
audrey_tepper@nps.gov

Scan 659.PDF



UNITED STATES DEPARTMENT OF THE INTERIOR
NATIONAL PARK SERVICE

OMB Approved
No. 1024-0009
Form 10-168
Rev. 2014

**HISTORIC PRESERVATION CERTIFICATION APPLICATION
AMENDMENT / ADVISORY DETERMINATION**

NPS Project Number 30491

Instructions: This page must bear the applicant's original signature and must be dated.

1. Property name Old Post Office and Clock Tower
Property address 1100 Pennsylvania Avenue, NW, Washington DC 20004

2. This form includes additional information requested by NPS for an application currently on hold.
 updates applicant or contact information.
 amends a previously submitted Part 1 Part 2 Part 3 application.
 requests an advisory determination that phase _____ of _____ phases of this rehabilitation project meets the Secretary of the Interior's Standards for Rehabilitation. Phase completion date _____
Estimated rehabilitation costs of phase (QRE) _____

Summarize information here; continue on following page if necessary.

In response to NPS's conditional approval received on June 26, 2014, Trump Old Post Office LLC provided a resubmittal on July 22, 2014. That document, in addition to the changes listed on the following page, are the basis of this amendment. If this amendment is approved, it would be an approval of the Part 2 as modified by the June 26, 2014 resubmittal and as further modified by this document and the items listed on the following page.

(continued following page)

3. Project Contact (if different from applicant)
Name David Orowitz Company Trump Old Post Office LLC
Street 725 5th Avenue City New York State NY
Zip 10022 Telephone (212) 836-3252 Email Address dorowitz@trumporg.com

4. Applicant
I hereby attest that the information I have provided is, to the best of my knowledge, correct. I further attest that [check one or both boxes, as applicable] (1) I am the owner of the above-described property within the meaning of "owner" set forth in 36 CFR § 67.2 (2011), and/or (2) If I am not the fee simple owner of the above-described property, the fee simple owner is aware of the action I am taking relative to this application and has no objection, as noted in a written statement from the owner, a copy of which (i) either is attached to this application form and incorporated herein, or has been previously submitted, and (ii) meets the requirements of 36 CFR § 67.3(a)(1) (2011). For purposes of this attestation, the singular shall include the plural wherever appropriate. I understand that knowing and willful falsification of factual representations in this application may subject me to fines and imprisonment under 18 U.S.C. § 1001, which, under certain circumstances, provides for imprisonment of up to 8 years.
Name Ivanka Trump Signature  Date 8/7/14
Applicant Entity Trump Old Post Office LLC SSN _____ or TIN 45-2671841
Street 60 Crossways Park Dr. West, Ste 301 City Woodbury State NY
Zip 11797 Telephone (212) 715-7256 Email Address itrump@trumporg.com
 Applicant, SSN, or TIN has changed since previously submitted application.

NPS Official Use Only

The National Park Service has reviewed this amendment to the Historic Preservation Certification Application and has determined that the amendment:

- meets the Secretary of the Interior's Standards for Rehabilitation.
- will meet the Secretary of the Interior's Standard for Rehabilitation if the attached conditions are met.
- does not meet the Secretary of the Interior's Standards for Rehabilitation.
- updates the information on file and does not affect the certification.

Advisory Determinations:

- The National Park Service has determined that the work completed in this phase is consistent with the Secretary of the Interior's Standards for Rehabilitation. This determination is advisory only. A formal certification of rehabilitation can be issued only after all rehabilitation work and any associated site work or new construction have been completed. This approval could be superseded if it is found that the overall rehabilitation does not meet the Secretary's Standards. A copy of this form will be provided to the Internal Revenue Service.

8.14.14
Date

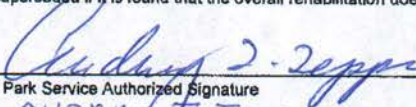
National Park Service Authorized Signature NPS-TPS (202) 354-2027
AUDREY J. TEPPER

NPS conditions or comments attached

Scan 660.PDF

UNITED STATES DEPARTMENT OF THE INTERIOR
NATIONAL PARK SERVICE

CONDITIONS SHEET -Amendment

Historic Preservation Certification Application

Property name: Old Post Office

Project Number: 30491

Property address: 1100 Pennsylvania Avenue, NW, Washington, DC

The National Park Service (NPS) has determined that this project will meet the Secretary of the Interior Standards for Rehabilitation if the condition(s) listed in the box above are met.

CONDITIONS FOR APPROVAL:

1. Conservation of Masonry and other Historic Materials:

There is a lack of information in the Part 2 and in the subsequent amendment to fully assess the location and condition of deteriorated masonry inside and outside of the building. To meet the Secretary's Standards, the documentation of and proposed treatments for this material are required for review and approval prior to repair. We *highly* recommend employing the services of a qualified architectural conservator. This individual may also assist in the conservation of other historic building materials found on site including, but not limited to, metal, glass and wood. Please note that the conservation of historic materials should be in accordance with the Programmatic Agreement (PA) with General Service Administration (GSA).

2. Tenant Guidelines:

Tenants leasing space on site must respect historic architectural features and finishes when retail or commercial fit-outs are undertaken. To assure protection of interior and exterior tenant areas, we recommend that guidelines be incorporated into leasing agreements. When available, we must also see all tenant improvements for review and approval prior to construction. The designs of tenant spaces should follow the PA through GSA.

3. Storage of Historic Doors:

The National Park Service (NPS) accepts the proposal that all unused historic doors will be stored in a protected off-site storage facility. NPS will collaborate with GSA to determine an acceptable location for this to occur.

4. Protection of Marble Floors:

The installation of carpeting must not damage historic marble flooring in any way. This condition applies to the first floor, as well as all other areas of the building where carpet is proposed over historic marble.

Information in response to the above conditions should be submitted for review and approval to the National Park Service, through the District Historic Preservation Office, when available.

The National Park Service has determined that this project will meet the Secretary of the Interior Standards for Rehabilitation if the condition(s) listed in the box above are met.

8/14/14

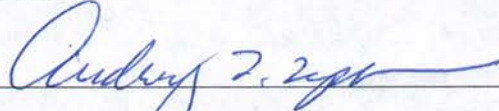

NPS-TPS 202-354-2027

Date

National Park Service Signature
Audrey T. Tepper

Telephone Number

RE_ Conditional Approval for OPO Amendment.pdf

From: [David Orowitz](#)
To: [Tepper, Audrey](#)
Subject: RE: Conditional Approval for OPO Amendment
Date: Thursday, August 14, 2014 12:12:40 PM

Thanks, Audrey. I am in India or I would call. Lot of discussion that I think resulted in a great outcome for everyone and the building. Have a great vacation.

David Orowitz
SVP, Acquisitions and Development
The Trump Organization
725 5th Avenue
New York, New York 10022
o: 212-836-3252 m: 646-315-4698
dorowitz@trumporg.com

----- Original message -----

From: "Tepper, Audrey"
Date: 08/14/2014 10:08 PM (GMT+05:30)
To: Ivanka Trump
Cc: David Orowitz ,Hany Hassan ,Andrew Lewis ,Brian Goeken
Subject: Conditional Approval for OPO Amendment

Dear Ivanka:

Attached is the conditional approval for the first Old Post Office amendment. With regular collaboration of the project team, we thankfully have made our way down the list of outstanding issues. This resulted in only a few conditions this round, which I believe are not terribly controversial. FYI, unless otherwise noted, what you propose in this current amendment is acceptable and you may proceed with construction.

If you have questions, please feel free to get in touch any time. I will be on leave from 8/18-8/26, but Andrew Lewis may be available in my absence.

Sincerely,

Audrey T. Tepper - LEED Green Associate
Historical Architect
National Park Service
Technical Preservation Services Branch
1201 Eye Street, NW - Org. 2200
Washington, DC 20005
202-354-2027
202-371-1616 (FAX)
audrey_tepper@nps.gov

This e-mail message, and any attachments to it, are for the sole use of the intended recipients, and may contain confidential and privileged information. Any unauthorized review, use, disclosure or distribution of this email message or its attachments is prohibited. If you are not the intended recipient, please contact the sender by reply email and destroy all copies of the original message. Please note that any views or opinions presented in this email are solely

those of the author and do not necessarily represent those of the company. Finally, while the company uses virus protection, the recipient should check this email and any attachments for the presence of viruses. The company accepts no liability for any damage caused by any virus transmitted by this email.

Re_ Conditional Approval for OPO Amendment_1.pdf

From: [Tepper, Audrey](#)
To: [David Orowitz](#)
Subject: Re: Conditional Approval for OPO Amendment
Date: Thursday, August 14, 2014 12:34:22 PM

We worked it out in the end, which I had confidence we would!

Hope you're not working too hard. Ivanka says you have a camping trip to look forward to upon your return. I hope it's far, far away from modern technology.

On Thu, Aug 14, 2014 at 2:12 PM, David Orowitz <dorowitz@trumporg.com> wrote:

Thanks, Audrey. I am in India or I would call. Lot of discussion that I think resulted in a great outcome for everyone and the building. Have a great vacation.

David Orowitz
SVP, Acquisitions and Development
The Trump Organization
725 5th Avenue
New York, New York 10022
o: 212-836-3252 m: 646-315-4698
dorowitz@trumporg.com

----- Original message -----

From: "Tepper, Audrey"
Date: 08/14/2014 10:08 PM (GMT+05:30)
To: Ivanka Trump
Cc: David Orowitz ,Hany Hassan ,Andrew Lewis ,Brian Goeken
Subject: Conditional Approval for OPO Amendment

Dear Ivanka:

Attached is the conditional approval for the first Old Post Office amendment. With regular collaboration of the project team, we thankfully have made our way down the list of outstanding issues. This resulted in only a few conditions this round, which I believe are not terribly controversial. FYI, unless otherwise noted, what you propose in this current amendment is acceptable and you may proceed with construction.

If you have questions, please feel free to get in touch any time. I will be on leave from 8/18-8/26, but Andrew Lewis may be available in my absence.

Sincerely,

Audrey T. Tepper - LEED Green Associate
Historical Architect
National Park Service
Technical Preservation Services Branch
1201 Eye Street, NW - Org. 2200
Washington, DC 20005
202-354-2027

202-371-1616 (FAX)

audrey_tepper@nps.gov

This e-mail message, and any attachments to it, are for the sole use of the intended recipients, and may contain confidential and privileged information. Any unauthorized review, use, disclosure or distribution of this email message or its attachments is prohibited. If you are not the intended recipient, please contact the sender by reply email and destroy all copies of the original message. Please note that any views or opinions presented in this email are solely those of the author and do not necessarily represent those of the company. Finally, while the company uses virus protection, the recipient should check this email and any attachments for the presence of viruses. The company accepts no liability for any damage caused by any virus transmitted by this email.

--

Audrey T. Tepper - LEED Green Associate
Historical Architect
National Park Service
Technical Preservation Services Branch
1201 Eye Street, NW - Org. 2200
Washington, DC 20005
202-354-2027
202-371-1616 (FAX)
audrey_tepper@nps.gov

RE_ Conditional Approval for OPO Amendment(1).pdf

From: [David Orowitz](#)
To: [Tepper, Audrey](#)
Subject: RE: Conditional Approval for OPO Amendment
Date: Thursday, August 14, 2014 12:49:48 PM

It is looking like a good week to get out of dodge. Hoping to disconnect as well.

David Orowitz
SVP, Acquisitions and Development
The Trump Organization
725 5th Avenue
New York, New York 10022
o: 212-836-3252 m: 646-315-4698
dorowitz@trumporg.com

----- Original message -----

From: "Tepper, Audrey"
Date: 08/15/2014 12:04 AM (GMT+05:30)
To: David Orowitz
Subject: Re: Conditional Approval for OPO Amendment

We worked it out in the end, which I had confidence we would!

Hope you're not working too hard. Ivanka says you have a camping trip to look forward to upon your return. I hope it's far, far away from modern technology.

On Thu, Aug 14, 2014 at 2:12 PM, David Orowitz <dorowitz@trumporg.com> wrote:

Thanks, Audrey. I am in India or I would call. Lot of discussion that I think resulted in a great outcome for everyone and the building. Have a great vacation.

David Orowitz
SVP, Acquisitions and Development
The Trump Organization
725 5th Avenue
New York, New York 10022
o: 212-836-3252 m: 646-315-4698
dorowitz@trumporg.com

----- Original message -----

From: "Tepper, Audrey"
Date: 08/14/2014 10:08 PM (GMT+05:30)
To: Ivanka Trump
Cc: David Orowitz ,Hany Hassan ,Andrew Lewis ,Brian Goeken
Subject: Conditional Approval for OPO Amendment

Dear Ivanka:

Attached is the conditional approval for the first Old Post Office amendment. With regular

collaboration of the project team, we thankfully have made our way down the list of outstanding issues. This resulted in only a few conditions this round, which I believe are not terribly controversial. FYI, unless otherwise noted, what you propose in this current amendment is acceptable and you may proceed with construction.

If you have questions, please feel free to get in touch any time. I will be on leave from 8/18-8/26, but Andrew Lewis may be available in my absence.

Sincerely,

Audrey T. Tepper - LEED Green Associate
Historical Architect
National Park Service
Technical Preservation Services Branch
1201 Eye Street, NW - Org. 2200
Washington, DC 20005
202-354-2027
202-371-1616 (FAX)
audrey_tepper@nps.gov

This e-mail message, and any attachments to it, are for the sole use of the intended recipients, and may contain confidential and privileged information. Any unauthorized review, use, disclosure or distribution of this email message or its attachments is prohibited. If you are not the intended recipient, please contact the sender by reply email and destroy all copies of the original message. Please note that any views or opinions presented in this email are solely those of the author and do not necessarily represent those of the company. Finally, while the company uses virus protection, the recipient should check this email and any attachments for the presence of viruses. The company accepts no liability for any damage caused by any virus transmitted by this email.

--

Audrey T. Tepper - LEED Green Associate
Historical Architect
National Park Service
Technical Preservation Services Branch
1201 Eye Street, NW - Org. 2200
Washington, DC 20005
202-354-2027
202-371-1616 (FAX)
audrey_tepper@nps.gov

Re_ Review of Original Photographs from the Old....pdf

From: [Keller, Jamie](#)
To: [Charleen Lyon](#)
Cc: [Nixon, Robin](#); [Laura Cohen](#); [David Orowitz](#)
Subject: Re: Review of Original Photographs from the Old Post Office Clock Tower Museum
Date: Tuesday, September 23, 2014 3:20:27 PM
Attachments: [CCL_Sig\[28\].png](#)
[CCL_Sig\[8\].png](#)
[CCL_Sig\[11\].png](#)

10am at Room 207, OPO is ok for me.

Jamie Keller
Supervisory Park Ranger
National Mall and Memorial Parks
(Cell) 202-505-0674

On Fri, Sep 19, 2014 at 1:49 PM, Charleen Lyon <clyon@cattlyondesign.com> wrote:

Jamie,

Weds morning, Sept 24, would be great. Shall we say 10am at Room 207, OPO?

Best Regards, Char

Charleen Catt Lyon
President

CATT LYON
DESIGN - WAYFINDING

53 W Jackson Blvd., #362
Chicago, Illinois 60604
Voice + 312.435.2855

1375 Broadway, Fl. 3
New York, New York 10018
Voice + 212.226.2626

212 Ludlow Avenue
Cincinnati, Ohio 45220
Voice + 513.221.3500



www.cattlyondesign.com

From: Jamie Keller <jamie_keller@nps.gov>
Date: Friday, September 19, 2014 at 12:31 PM
To: Charleen Lyon <clyon@cattlyondesign.com>
Cc: "'Nixon, Robin'" <robin_nixon@nps.gov>, Laura Cohen <laura_cohen@nps.gov>, David Orowitz <dorowitz@trumporg.com>
Subject: Re: FW: Review of Original Photographs from the Old Post Office Clock Tower Museum

Hi Charleen-

I could meet Wednesday morning if that works. Let me know.

Regards,

Jamie Keller
Supervisory Park Ranger
National Mall and Memorial Parks
(Cell) 202-505-0674

On Thu, Sep 18, 2014 at 4:26 PM, Charleen Lyon <clyon@cattlyondesign.com> wrote:

Folks,

I sent you this email last Monday. Please let me know if one of you has time to meet on Tuesday to answer a few questions.

Thanks, Char

Charleen Catt Lyon
President

CATT LYON
DESIGN - WAYFINDING



53 W Jackson Blvd., #362
Chicago, Illinois 60604
Voice + 312.435.2855

1375 Broadway, Fl. 3
New York, New York 10018
Voice + 212.226.2626

212 Ludlow Avenue
Cincinnati, Ohio 45220
Voice + 513.221.3500

www.cattlyondesign.com

From: Charleen Lyon <clyon@cattlyondesign.com>

Date: Monday, September 15, 2014 at 2:54 PM

To: "Nixon, Robin" <robin_nixon@nps.gov>, Laura Cohen <laura_cohen@nps.gov>, Jamie Keller <jamie_keller@nps.gov>

Cc: David Orowitz <dorowitz@trumporg.com>

Subject: Review of Original Photographs from the Old Post Office Clock Tower Museum

Robin, Laura and Jamie,

I am not sure who among you would be the best to help me, but please let me know if one of you could meet with me next Tuesday afternoon (Sep 23) or Weds morning (Sep 24) to review photocopies of some of the original photos that were in the Clock Tower Museum at the Old Post Office.

We have photos of the photos, but we don't always have the interpretation that might have gone with them. Nor do we always know the source.

I will be in town next week and I was hoping we could sit down for an hour or so, and go through them.

Please advise if one of you could be available.

Best Regards, Char

Charleen Catt Lyon
President

CATT LYON
DESIGN - WAYFINDING



53 W Jackson Blvd., #362
Chicago, Illinois 60604
Voice + 312.435.2855

1375 Broadway, Fl. 3
New York, New York 10018
Voice + 212.226.2626

212 Ludlow Avenue
Cincinnati, Ohio 45220
Voice + 513.221.3500

www.cattlyondesign.com

yesterdays meeting.pdf

From: [Keith Schiller](#)
To: Richard_Pope@nps.gov
Subject: yesterdays meeting
Date: Wednesday, October 01, 2014 8:37:15 AM

Richard,

First I would like to say it was a pleasure meeting you yesterday. I am looking forward to working with you in the future.

If there is anything you need from us please don't hesitate to ask.

Wishing you the best,

Keith

T R U M P

THE TRUMP ORGANIZATION

Keith Schiller

Director of Security

725 Fifth Avenue | New York, NY | 10022

p. 212.832-2000 | f. 212.935.0141

kschiller@trumporg.com | trump.com

This e-mail message, and any attachments to it, are for the sole use of the intended recipients, and may contain confidential and privileged information. Any unauthorized review, use, disclosure or distribution of this email message or its attachments is prohibited. If you are not the intended recipient, please contact the sender by reply email and destroy all copies of the original message. Please note that any views or opinions presented in this email are solely those of the author and do not necessarily represent those of the company. Finally, while the company uses virus protection, the recipient should check this email and any attachments for the presence of viruses. The company accepts no liability for any damage caused by any virus transmitted by this email.

Old Post Office - GSA_SHPO_NPS meeting.pdf

From: [Jill Cavanaugh](#)
To: [Hany Hassan](#); [Nancy Witherell - WPDC](#); [Stephen Dalton \(sdalton@trumporg.com\)](#); [Oksana Chernyaeva](#); [audrey_tepper@nps.gov](#); [andrew.lewis@dc.gov](#); [Chris Wiley](#)
Subject: Old Post Office - GSA/SHPO/NPS meeting

scheduled anti Trump protest on 7_9_2015.pdf

From: [Keith Schiller](#)
To: charles_guddemi@nps.gov
Cc: [Matthew Calamari](#)
Subject: scheduled anti Trump protest on 7/9/2015
Date: Wednesday, July 08, 2015 12:10:25 PM

Dear Major Guddemi,

Please be advised that I am told by our staff at our Old Post Office location located at Pennsylvania Ave. and 12th street there is a planned anti Trump protest scheduled for 12pm tomorrow July 9, 2015.

From what I understand there are supposed to be approximately 100 plus protesters and media.

My question to you is will there be Parks Dept. personnel along with Metro Police on site and if so how many will be dedicated to the protest?

If you need or have any further questions please contact me via email or my cell (b) (6)

Thank you in advance.

T R U M P
THE TRUMP ORGANIZATION

Keith Schiller
Director of Security
725 Fifth Avenue | New York, NY | 10022
p. 212.832-2000 | f. 212.935.0141
kschiller@trumporg.com | trump.com

This e-mail message, and any attachments to it, are for the sole use of the intended recipients, and may contain confidential and privileged information. Any unauthorized review, use, disclosure or distribution of this email message or its attachments is prohibited. If you are not the intended recipient, please contact the sender by reply email and destroy all copies of the original message. Please note that any views or opinions presented in this email are solely those of the author and do not necessarily represent those of the company. Finally, while the company uses virus protection, the recipient should check this email and any attachments for the presence of viruses. The company accepts no liability for any damage caused by any virus transmitted by this email.

Re_scheduled anti Trump protest on 7_9_2015.pdf

From: [Guddemi, Charles](#)
To: [Keith Schiller](#)
Cc: [Matthew Calamari](#); [Sund, Steven A. \(MPD\)](#); [jefferyw.carroll](#); [Steven Booker](#); [James Murphy](#); [Christopher Paschel](#)
Subject: Re: scheduled anti Trump protest on 7/9/2015
Date: Wednesday, July 08, 2015 1:20:26 PM

MR. Schiller

It was a pleasure speaking with you.

The sidewalks on Pennsylvania Ave are the property of the National Park Service and the United States Park Police (USPP) are the primary law enforcement agency to handle incidents on the sidewalk.

The D.C. Metropolitan Police (MPD) are responsible for the city streets and sidewalks around most of the new Trump property. We work very closely with the MPD on a daily basis.

Points of Contact for the MPD are :

Special Operations Division

Commander Steve Sund cell (b) (6)

Captain Jeffery Carroll cell (b) (6)

Points of Contact for the USPP:

other than myself (cell (b) (6))

Captain Steve Booker, Commander of Special Forces (b) (6)

LT. James Murphy, Commander of Special Events Unit (b) (6)

Mr. Chris Paschel, Intelligence Unit Branch Director (b) (6)

The National Park Service has received an application for a permit for an assembly at Freedom Plaza and for the sidewalk on the 1100 block of

Pennsylvania Ave.

Charlie

Media Advisory

***Elected Officials
and Community
Leaders join forces
to protest against
Donald Trump in
front of future site
of Donald Trump
Hotel in DC (Old
Post Office
building)***

On June 16, 2015, at a Press Conference, Republican Candidate Donald Trump announced his candidacy to run for the Presidency of the United States. While using this platform to reach the American public, Mr. Trump made remarks dehumanizing and criminalizing immigrants from Mexico and Latin America. During the

press conference, Mr. Trump said: *“When Mexico brings its people, they’re not sending their best. They’re sending people that have lots of problems, they’re bringing drugs, they’re bringing crime. They’re rapists. And some, I assume, are good people. It’s coming from all of South and Latin America.”*

In response to Mr. Trump’s disparaging and dangerous comments to our community, concerned elected officials, community leaders, and others, will protest in front of the location of Mr. Trump’s celebrated DC luxury hotel project, at the Old U.S. Post Office building.

WHAT:
Demonstration and
Protest against
Republican
Presidential Candidate

Donald
Trump in Washington
DC

WHO: U.S.
Representative
(Shadow) Franklin
Garcia, District of
Columbia

U.S.
Senator Paul Strauss,
District of Columbia

U.S.
Senator Michael D.
Brown, District of
Columbia

Maryland
State Delegate, Ana
Sol Gutiérrez

Maryland State
Delegate, Joseline
Peña-Melnyk

Arlington County
Board, J. Walter

Tejada

DC

Latino Caucus
President, Gabriela
Mossi

LGBT

Community Activist,
Jose Gutierrez

And

others

WHEN: Thursday,
July 9, 2015, 1:30
p m. to 2:30 pm.

WHERE: 1100
Pennsylvania Avenue,
NW, Washington DC
at 12th Street,

Federal

Triangle Metro

CONTACT: Deneysa
Richard (202)-817-
0792, information@dc51.us

On Wed, Jul 8, 2015 at 2:09 PM, Keith Schiller <kschiller@trumporg.com> wrote:

Dear Major Guddemi,

Please be advised that I am told by our staff at our Old Post Office location located at Pennsylvania

Ave. and 12th street there is a planned anti Trump protest scheduled for 12pm tomorrow July 9, 2015.

From what I understand there are supposed to be approximately 100 plus protesters and media.

My question to you is will there be Parks Dept. personnel along with Metro Police on site and if so how many

will be dedicated to the protest?

If you need or have any further questions please contact me via email or my cell (b) (6)

Thank you in advance.

T R U M P
THE TRUMP ORGANIZATION

Keith Schiller
Director of Security
725 Fifth Avenue | New York, NY | 10022
p. 212.832-2000 | f. 212.935.0141

kschiller@trumporg.com | trump.com

This e-mail message, and any attachments to it, are for the sole use of the intended recipients, and may contain confidential and privileged information. Any unauthorized review, use, disclosure or distribution of this email message or its attachments is prohibited. If you are not the intended recipient, please contact the sender by reply email and destroy all copies of the original message. Please note that any views or opinions presented in this email are solely those of the author and do not necessarily represent those of the company. Finally, while the company uses virus protection, the recipient should check this email and any attachments for the presence of viruses. The company accepts no liability for any damage caused by any virus transmitted by this email.

--

Major Charles J. Guddemi
Commander, ICON Protection Branch
United States Park Police
1100 Ohio Drive S.W.
Washington, D.C. 20024

E-mail: Charles_Guddemi@nps.gov

Office: (202) 610-7091

Fax : (202) 426-0612

OPO review.pdf

From: [Jennie Gwin](#)
To: audrey_tepper@nps.gov; andrew.lewis@dc.gov; nancy.witherell@gsa.gov; [Hany Hassan](#); [Stephen Dalton](#)
Subject: OPO review

NPS Project 30491_ Old Post Office and Clock Tower.pdf

From: [Lester, Kayla](#)
To: itrump@trumporg.com; dorowitz@trumporg.com
Cc: andrew.lewis@dc.gov; [Audrey Tepper](#)
Subject: NPS Project 30491: Old Post Office and Clock Tower
Date: Thursday, October 01, 2015 10:40:46 AM

NPS has received the amendment/response to the conditions for the Old Post Office and Clock Tower, however after speaking with the reviewer we will need an amendment cover sheet that describes the additional information provided. Please put the amendment on our revised 2014 form. Below is a link to our website where the new form can be downloaded. ***Please read & follow the downloading directions carefully.*** The amendment can be scanned and sent back to this e-mail.

<http://www.nps.gov/tps/tax-incentives/application.htm>

Thank You

--

Kayla Lester
Program Assistant
National Park Service
Technical Preservation Services, WASO
(202)354-2042

Mail: 1201 Eye Street, NW
Washington, DC 20005

TPS website <http://www.nps.gov/tps/>

Like us on Facebook <http://www.facebook.com/HHPreservItNPS>

Follow us on Twitter [@HHPreservItNPS](#)

Confidentiality Notice: this transmission is intended for the sole use of the addressee and may contain information that is privileged and confidential. If you are not the intended recipient, any dissemination of this communication is strictly prohibited. If you have received this communication in error, please notify the sender immediately by telephone.



Out of Office_ NPS Project 30491_ Old Post Offi....pdf

From: [David Orowitz](#)
To: [Lester, Kayla](#)
Subject: Out of Office: NPS Project 30491: Old Post Office and Clock Tower
Date: Thursday, October 01, 2015 10:40:56 AM

Dave will be out of the office with minimal access to email until Tuesday, October 6th. If you require an immediate response, please contact his assistant, Kelly Howell, at 212-715-7219

This e-mail message, and any attachments to it, are for the sole use of the intended recipients, and may contain confidential and privileged information. Any unauthorized review, use, disclosure or distribution of this email message or its attachments is prohibited. If you are not the intended recipient, please contact the sender by reply email and destroy all copies of the original message. Please note that any views or opinions presented in this email are solely those of the author and do not necessarily represent those of the company. Finally, while the company uses virus protection, the recipient should check this email and any attachments for the presence of viruses. The company accepts no liability for any damage caused by any virus transmitted by this email.

NPS Project 30491_ Old Post Office and Clock To....pdf

From: [Jennie Gwin](#)
To: kayla_lester@nps.gov
Cc: dorowitz@trumporg.com; [Hany Hassan](#); audrey_tepper@nps.gov; andrew.lewis@dc.gov
Subject: NPS Project 30491: Old Post Office and Clock Tower amendment form
Date: Wednesday, October 07, 2015 3:00:19 PM
Attachments: [30491 OPO conditional approval response 2015-10-7.pdf](#)

Ms. Lester,

Per your request please find attached the conditional approval response package that we submitted to Audrey Tepper on August 14 with the official NPS amendment cover sheet. Please let me know if you require any additional information.

Thank you,

Jennie Gwin AIA

Associate

**BEYER BLINDER BELLE
ARCHITECTS & PLANNERS LLP**

3307 M Street, NW, Suite 301

Washington, DC 20007

202.333.8006 direct

www.beyerblinderbelle.com

The above e-mail is for the intended recipient only, and may contain information that is privileged, confidential, or otherwise protected from disclosure. If you are not the intended recipient, please advise the sender immediately. Nothing in this e-mail or any attachments to this e-mail grants any license or transfers any ownership to the contents of the e-mail or attachments or any intellectual property rights contained therein. Unauthorized use or distribution is prohibited and may be unlawful. Beyer Blinder Belle Architects Planners LLP accepts no responsibility for any loss or damage from the use of this message and/or any attachments including damage from viruses.

30491 OPO conditional approval response 2015-1.pdf



UNITED STATES DEPARTMENT OF THE INTERIOR
NATIONAL PARK SERVICE

OMB Approved
No. 1024-0009
Form 10-168
Rev. 2014

**HISTORIC PRESERVATION CERTIFICATION APPLICATION
AMENDMENT / ADVISORY DETERMINATION**

NPS Project Number
30491

Instructions: This page must bear the applicant's original signature and must be dated.

1. Property name Old Post Office and Clock Tower
Property address 1100 Pennsylvania Avenue, NW

- 2. This form includes additional information requested by NPS for an application currently on hold.
- updates applicant or contact information.
- amends a previously submitted Part 1 Part 2 Part 3 application.
- requests an advisory determination that phase _____ of _____ phases of this rehabilitation project meets the Secretary of the Interior's Standards for Rehabilitation. Phase completion date _____
- Estimated rehabilitation costs of phase (QRE) \$160,000,000

Summarize information here; continue on following page if necessary.

The attached package was provided to Audrey Tepper on August 14, 2015 in response to her conditional approval of the OPO amendment package dated May 18, 2015. Ms. Tepper's conditional approval was dated August 6, 2015. Per NPS request we are resubmitting the package with a new amendment application form. This conditional approval response package includes the original amendment form, conditions sheet, Conditions Response Matrix, photographs of the east and west elevator lobby ceilings with utilities, Sheet A9.02a with revised detailed for west elevator lobby cloud, and sheet A8.01.

3. Project Contact (if different from applicant)

Name David Orowitz Company Trump Old Post Office LLC

Street 725 5th Avenue City New York State NY

Zip 10022 Telephone (212) 836-3252 Email Address dorowitz@trumporg.com

4. Applicant

I hereby attest that the information I have provided is, to the best of my knowledge, correct. I further attest that [check one or both boxes, as applicable] (1) I am the owner of the above-described property within the meaning of "owner" set forth in 36 CFR § 67.2 (2011), and/or (2) if I am not the fee simple owner of the above-described property, the fee simple owner is aware of the action I am taking relative to this application and has no objection, as noted in a written statement from the owner, a copy of which (i) either is attached to this application form and incorporated herein, or has been previously submitted, and (ii) meets the requirements of 36 CFR § 67.3(a)(1) (2011). For purposes of this attestation, the singular shall include the plural wherever appropriate. I understand that knowing and willful falsification of factual representations in this application may subject me to fines and imprisonment under 18 U.S.C. § 1001, which, under certain circumstances, provides for imprisonment of up to 8 years.

Name Ivanka Trump Signature  Date _____

Applicant Entity Trump Old Post Office LLC SSN _____ or TIN 45-2671841

Street 60 Crossways Park Dr. West, Ste 301 City Woodbury State NY

Zip 11797 Telephone (212) 715-7256 Email Address itrump@trumporg.com

Applicant, SSN, or TIN has changed since previously submitted application.

NPS Official Use Only

The National Park Service has reviewed this amendment to the Historic Preservation Certification Application and has determined that the amendment:

- meets the Secretary of the Interior's Standards for Rehabilitation.
- will meet the Secretary of the Interior's Standard for Rehabilitation if the attached conditions are met.
- does not meet the Secretary of the Interior's Standards for Rehabilitation.
- updates the information on file and does not affect the certification.

Advisory Determinations:

- The National Park Service has determined that the work completed in this phase is consistent with the Secretary of the Interior's Standards for Rehabilitation. This determination is advisory only. A formal certification of rehabilitation can be issued only after all rehabilitation work and any associated site work or new construction have been completed. This approval could be superseded if it is found that the overall rehabilitation does not meet the Secretary's Standards. A copy of this form will be provided to the Internal Revenue Service.

Date _____ National Park Service Authorized Signature _____

- NPS conditions or comments attached

**HISTORIC PRESERVATION CERTIFICATION APPLICATION
AMENDMENT / ADVISORY DETERMINATION**

Property name Old Post Office and Clock Tower NPS Project Number 30491
Property address 1100 Pennsylvania Avenue, NW

August 14, 2015

Audrey Tepper
National Park Service
Technical Preservation Services Branch
1201 Eye Street, NW
Washington, DC 20005

RE: Old Post Office Tax Credit Amendment #3 Conditional Approval

Dear Audrey,

We are in receipt of your conditional approval form for the OPO Amendment #3 application. Please see attached condition response matrix for our responses to the conditions and questions outlined in your conditional approval. We have also included drawing sheets and photographs to assist you in your review.

Please feel free to contact me directly if you have comments or questions.

Sincerely,

A handwritten signature in black ink, appearing to read 'Hany Hassan', with a long horizontal flourish extending to the right.

Hany Hassan, FAIA

Attached:

Conditional Approval Form
Comment Response Matrix
Photographs of east and west elevator lobby ceilings with utilities
Sheet A9.02a with revised details for west elevator lobby cloud
A8.01



UNITED STATES DEPARTMENT OF THE INTERIOR
NATIONAL PARK SERVICE

OMB Approved
No. 1024-0009
Form 10-168
Rev. 2014

**HISTORIC PRESERVATION CERTIFICATION APPLICATION
AMENDMENT / ADVISORY DETERMINATION**

NPS Project Number
30491

Instructions: This page must bear the applicant's original signature and must be dated.

1. Property name Old Post Office and Clock Tower
Property address 1100 Pennsylvania Avenue, NW

2. This form includes additional information requested by NPS for an application currently on hold.
 updates applicant or contact information.
 amends a previously submitted Part 1 Part 2 Part 3 application.
 requests an advisory determination that phase _____ of _____ phases of this rehabilitation project meets the Secretary of the Interior's Standards for Rehabilitation. Phase completion date _____
 Estimated rehabilitation costs of phase (QRE) \$160,000,000

Summarize information here; continue on following page if necessary.

In response to NPS's conditional approval received on June 26, 2014 Trump Old Post Office LLC provided a re-submittal on July 22, 2014. That document was amended by an amendment submitted August 8, 2014. The basis of this amendment are the July 2014 Part 2 resubmission and August 2014 amendment. If this amendment is approved, it would be an approval of the Part 2 as modified on June 26th, 2014, August 8, 2014, and further modified by this document and the items listed on the following page. Only revised or new tax cards and supplementary drawings are included in this submission.

3. Project Contact (if different from applicant)
Name David Orowitz Company Trump Old Post Office LLC
Street 725 5th Avenue City New York State NY
Zip 10022 Telephone (212) 836-3252 Email Address dorowitz@trumporg.com

4. Applicant
 I hereby attest that the information I have provided is, to the best of my knowledge, correct. I further attest that [check one or both boxes, as applicable] (1) I am the owner of the above-described property within the meaning of "owner" set forth in 36 CFR § 67.2 (2011), and/or (2) if I am not the fee simple owner of the above-described property, the fee simple owner is aware of the action I am taking relative to this application and has no objection, as noted in a written statement from the owner, a copy of which (i) either is attached to this application form and incorporated herein, or has been previously submitted, and (ii) meets the requirements of 36 CFR § 67.3(a)(1) (2011). For purposes of this attestation, the singular shall include the plural wherever appropriate. I understand that knowing and willful falsification of factual representations in this application may subject me to fines and imprisonment under 18 U.S.C. § 1001, which, under certain circumstances, provides for imprisonment of up to 8 years.

Name Ivanka Trump Signature  Date 5/18/15
 Applicant Entity Trump Old Post Office LLC SSN _____ or TIN 45-2671841
 Street 60 Crossways Park Dr. West, Ste 301 City Woodbury State NY
 Zip 11797 Telephone (212) 715-7256 Email Address itrump@trumporg.com
 Applicant, SSN, or TIN has changed since previously submitted application.

NPS Official Use Only

The National Park Service has reviewed this amendment to the Historic Preservation Certification Application and has determined that the amendment:

- meets the Secretary of the Interior's Standards for Rehabilitation.
 will meet the Secretary of the Interior's Standard for Rehabilitation if the attached conditions are met.
 does not meet the Secretary of the Interior's Standards for Rehabilitation.
 updates the information on file and does not affect the certification.

Advisory Determinations:

- The National Park Service has determined that the work completed in this phase is consistent with the Secretary of the Interior's Standards for Rehabilitation. This determination is advisory only. A formal certification of rehabilitation can be issued only after all rehabilitation work and any associated site work or new construction have been completed. This approval could be superseded if it is found that the overall rehabilitation does not meet the Secretary's Standards. A copy of this form will be provided to the Internal Revenue Service.

8.6.15
Date

Audrey T. Terrior
National Park Service Authorized Signature

NPS TPS

202-354-2027

NPS conditions or comments attached

UNITED STATES DEPARTMENT OF THE INTERIOR
NATIONAL PARK SERVICE

CONDITIONS SHEET – *Amendment*

Property name: Old Post Office

Project Number: 30491

Property address: 1100 Pennsylvania Avenue, Washington, DC

The rehabilitation of this property as described in the Historic Preservation Certification Application will meet the Secretary of the Interior's Standards for Rehabilitation provided that the following condition(s) is/are met:

Scaffolding:

Every attempt must be made to protect the historic Old Post Office when the newly-designed the scaffolding system is installed, as well as when this system is deconstructed. This will require temporary protection of the stone and any other significant historic architectural fabric in the process. Of special concern are locations where the scaffolding comes in direct contact with the building. In these instances, additional padding may be necessary.

As indicated in the submittal, the scaffolding will be anchored to the building in select locations (stainless steel anchors only) by drilling into mortar joints, which can be repaired, as opposed to drilling directly into the masonry, which cannot be repaired. Please note the number of holes drilled into the mortar must be kept to an absolute minimum. Furthermore, drilling into the masonry for securing the scaffolding is *strictly* prohibited.*

Anchor penetrations will be left in place for future scaffolding of the building. After this construction campaign, these areas will also be covered with rubber hosing to seal the penetrations from water infiltration. When the scaffolding is dismantled, the penetrations must be repaired and obscured with mortar that matches the color, texture, strength, and joint width of the existing mortar. Jahn Mortar is specified for this treatment. This work must be accomplished in accordance with the guidelines provided in "Preservation Brief 2, *Repointing Mortar Joints in Historic Masonry Buildings*" - <http://www.nps.gov/tps/how-to-preserve/briefs/2-repoint-mortar-joints.htm>. Good quality close-up and overall photographs of the masonry before and after repair must be submitted with the *Request for Certification of Completed Work/Part 3*.

*We understand that minute portions of the granite face may be affected by the installation of scaffolding. Provided no additional historic fabric is removed beyond what is specified (1/4" above and below the joints in limited areas), we accept this change on this large building.

New Ceiling Clouds:

This amendment introduces piping and other utilities in east and west elevator lobbies on all upper floors. Since these spaces are what visitors will experience first upon entering hotel floors, the fewest number of changes must occur in these locations. Therefore, installing utilities here and attempting to hide them above suspended "clouds" is not recommended, as is using these panels as the primary means of hanging lighting fixtures. Can these panels be removed entirely, with only the bare minimum of services left in place? Can utilities be relocated to less visible areas, as well as lighting hung using alternative, less intrusive methods? Please revise the designs of these areas to lessen the impact of new services in these areas.

Revised treatment card No. 74 states that a "floating suspended ceiling" will be inserted on the 5th Floor. Is this in the vestibule to the guest suite, which was discussed at some length at a site visit with NPS? The plan on the card is hard to decipher. Also, a detail of this feature did not be provided in the amendment drawing set.

Restaurant Space (Northwest Corner):

Restaurant Ceiling:

As proposed, treatments for the damaged historic ceiling in the northwest restaurant space meet the Secretary's Standards. Please note every attempt must be made to retain and repair as many original features in this space as possible. Areas that have already experienced severe damage may be covered, but not removed entirely.

All new changes to this restaurant space, beyond what is presented in this amendment, must be submitted to the National Park Service, through the DC Historic Preservation Office *prior* to construction.

Storefront:

The storefront at the restaurant space (along the 12th Street corridor) may be constructed as proposed, provided the glass to be used remains translucent. No fully-transparent glass is permitted at this historically solid wall.

3rd Floor Roof Terrace – Pennsylvania Avenue:

Treatment card No. 167 states, “... a new wood deck will be added on top of the existing roof” for the sake of appearance. Will any other features be placed in this location? Please note new, tall additions to this roof beyond flags and flagpoles (plantings, lighting, furniture, structures, etc.) must not be installed because they are out of character with this historic institutional building.

Modification of Hand Rails:

Drawing A2.01 – OPO First Floor Plan indicates that new handrails and guards will be installed at the Elevator 3 stairway, but a detail of this change was not included with this submittal. Was this alteration previously approved, or is it new? If new, additional information is required for review and approval.

The National Park Service has determined that this project will meet the Secretary of the Interior Standards for Rehabilitation if the condition(s) listed in the box above are met.

08/6/ 2015

202-354-2027

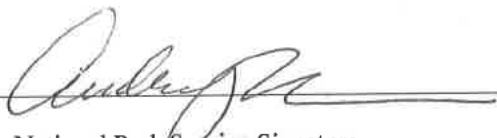

Date

National Park Service Signature
Audrey T. Tepper

Telephone Number

Tax Credit: Part 2 Amendment #3 Conditions Response Matrix

	Condition	Explanation	Response
1	Scaffolding	<p>Every attempt must be made to protect the historic Old Post Office when the newly - designed the scaffolding system is installed, as well as when this system is deconstructed. This will require temporary protection of the stone and any other significant historic architectural fabric in the process. Of special concern are locations where the scaffolding comes in direct contact with the building. In these instances, additional padding may be necessary.</p> <p>As indicated in the submittal, the scaffolding will be anchored to the building in select locations (stainless steel anchors only) by drilling into mortar joints, which can be repaired, as opposed to drilling directly into the masonry, which cannot be repaired. Please note the number of holes drilled into the mortar must be kept to an absolute minimum. Furthermore, drilling into the masonry for securing the scaffolding is strictly prohibited.*</p> <p>Anchor penetrations will be left in place for future scaffolding of the building. After this construction campaign, these areas will also be covered with rubber hosing to seal the penetrations from water infiltration. When the scaffolding is dismantled, the penetrations must be repaired and obscured with mortar that matches the color, texture, strength, and joint width of the existing mortar. Jahn Mortar is specified for this treatment. This work must be accomplished in accordance with guidelines provided in “Preservation Brief 2, <i>Repointing Mortar Joints in Historic Masonry Buildings</i>” – http://www.nps.gov/tps/how-to-preserve/briefs/2-repoint-mortar-joints.htm. Good quality close-up and overall photographs of the masonry before and after repair must be submitted with the <i>Request for Certification of Completed Work/Part 3</i>.</p> <p>*We understand that minute portions of the granite face may be affected by the installation of scaffolding. Provided no additional historic fabric is removed beyond what is specified (1/4” above and below the joints in limited areas), we accept this change on this large building.</p>	<p>All scaffolding will be installed per the submitted scaffolding plan and your instructions. Anchoring will be limited to mortar joints and damage to the granite will be kept to an absolute minimum. All mortar repairs will follow Preservation Brief 2.</p>
2	New Ceiling Clouds	<p>This amendment introduces piping and other utilities in east and west elevator lobbies on all upper floors. Since these spaces are what visitors will experiences first upon entering hotel floors, the fewest number of changes must occur in these locations. Therefore, installing utilities here and attempting to hide them above suspended “clouds” is not recommended, as is using these panels as the primary means of hanging lighting fixtures. Can these panels be removed entirely, with only the bare minimum of services left in place? Can utilities be relocated to less visible areas, as well as lighting hung using alternative, less intrusive methods? Please revise the designs of these areas to lessen the impact of new services in these areas. Revised treatment card No. 74 states that a “floating suspended ceiling” will be inserted on the 5th Floor. Is this in the vestibule to the guest suite, which was discussed at some length at a site visit with NPS? The plan on the card is hard to decipher. Also, a detail of this feature did was not provided amendment drawing set.</p>	<p>We have looked at this condition closely to see if there is any possibility to route the utilities elsewhere. The utilities must be located in the elevator lobbies in order to avoid locating them in the corridor. The fire alarm and sprinkler must be installed in a continuous loop. Therefore the conduits and piping must either transverse the two elevator lobbies or be installed throughout the corridor that rings the cortile. We feel that locating that the utilities in the lobbies is the less visually obtrusive option.</p> <p>Please see attached photos of the installed conditions of the sprinkler pipes, conduits, wiring, and devices at the east and west elevator lobbies. We feel that eliminating the clouds and leaving the sprinkler main, branch sprinkler piping, and fire alarm conduit exposed would detract from the historic fabric of the space. If the utilities were shifted to one side of the lobbies it would obscure the cornice along that elevation and the spaces are so narrow that the utilities would still be visible from almost all vantage points.</p>

Tax Credit: Part 2 Amendment #3 Conditions Response Matrix

			<p>We think the best way to lessen the visual impact of new services would be to leave the cloud in the east lobby as shown on details 1 and 6 of sheet A9.02 and to raise the cloud in the west elevator lobby to be at the same height as the east lobby cloud and make the west cloud more narrow to reveal more of the cornice (please see attached revised sheet A9.02a indicating the higher elevation of sprinkler main and proposed modifications to the west cloud). We also feel that the cove lighting located in the clouds allows for illumination of the cornice and highlights the historic details of the building.</p> <p>The “floating suspended ceiling” referenced on card 74 refers to the cloud ceilings that are being installed throughout the 5th floor guestrooms. This was included in Amendment #1. The revised detail for the vestibule lobbies that was reviewed and discussed at length this spring will be included in a future amendment package.</p>
3	<p>Restaurant Space (Northwest Corner)</p>	<p>Restaurant Ceiling: As proposed, treatments for the damaged historic ceiling in the northwest restaurant space meet the Secretary’s Standards. Please note every attempt must be made to retain and repair as many original features in this space as possible. Areas that have already experienced severe damage may be covered, but not removed entirely.</p> <p>All new changes to this restaurant space, beyond what is presented in this amendment, must be submitted to the National Park Service, through the DC Historic Preservation Office <i>prior</i> to construction.</p> <p>Storefront: The storefront at the restaurant space (along the 12th Street corridor) may be constructed as proposed, provided the glass to be used remains translucent. No fully-transparent glass is permitted at this historically solid wall.</p>	<p>Any future revisions to the restaurant design submitted in this amendment package will be submitted to SHPO and NPS for review and approval. The storefront will not have transparent glass.</p>
4	<p>3rd Floor Roof Terrace Pennsylvania Avenue</p>	<p>Treatment card No. 167 states, “...a new wood deck will be added on top of the existing roof” for the sake of appearance. Will any other features be placed in this location? Please note new, tall additions to this roof beyond flags and flagpoles (plantings, lighting, furniture, structures, etc.) must not be installed because they are out of character with this historic institutional building.</p>	<p>No additions that would be visible from the street will be added to the terrace. The new planters shown in 4/A12.12 will be low and are installed only to conceal the large bases of the flag posts from the guestrooms above.</p>
5	<p>Modification of Hand Rails</p>	<p>Drawing A2.01 – OPO First Floor Plan indicates that new handrails and guards will be installed at the Elevator 3 stairway, but a detail of this change was not included with this submittal. Was this alteration previously approved, or is it new? If new, additional information is required for review and approval.</p>	<p>The existing railing at the east and west elevator lobby stairs is 10” lower than the code required height for guardrails, requiring the installation of new glazed guard and handrails for safety reasons. Tax Card 79 and drawing A8.01, that provide details of the new glazed guard and handrail were submitted and approved in the first amendment package approved June of 2014. We have attached sheet A8.01 for your reference.</p>





Themes for Old Post Office Museum.pdf

From: [David Orowitz](#)
To: [Keller, Jamie](#); [Nixon, Robin](#); [Laura Cohen](#)
Cc: [Brett Banks \(brett.banks@gsa.gov\)](#); [clyon@cattlyondesign.com](#); [Simon Lyon](#)
Subject: Themes for Old Post Office Museum
Date: Friday, October 30, 2015 12:35:59 PM
Attachments: [2015_10_26 TOPO Museum Layout.pdf](#)

Robin, Jamie, and Laura,

Hope all is well. As it has been a while, I wanted to give you a quick update on the status for the Trump portion of the museum. We have been on hold for a while as the rest of the building got further developed, but please find attached the basic “themes” that we plan to include in the museum. Once these get developed, we will share again prior to finalizing, but wanted to keep you in the loop on status.

If there is anyone else from NPS that should have been on here, I apologize and please forward on to them. If you have any questions or comments, please feel free to give me a call.

Best,
Dave

David Orowitz
Senior Vice President, Acquisitions and Development
The Trump Organization
725 Fifth Avenue | New York, NY | 10022
p. 212.836.3252 | m. 646.315.4698 | f. 212.836.3202
dorowitz@trumporg.com | trump.com

This e-mail message, and any attachments to it, are for the sole use of the intended recipients, and may contain confidential and privileged information. Any unauthorized review, use, disclosure or distribution of this email message or its attachments is prohibited. If you are not the intended recipient, please contact the sender by reply email and destroy all copies of the original message. Please note that any views or opinions presented in this email are solely those of the author and do not necessarily represent those of the company. Finally, while the company uses virus protection, the recipient should check this email and any attachments for the presence of viruses. The company accepts no liability for any damage caused by any virus transmitted by this email.

2015_10_26 TOPO Museum Layout.pdf



CATT LYON
DESIGN + WAYFINDING

53 W Jackson Blvd, #362
Chicago, IL 60604
Voice 312 435 2855

1375 Broadway Fl. 3
New York, NY 10018
Voice 212 226 2626

212 Ludow Avenue
Cincinnati, OH 45220
Voice 513 221 3500

www.cattlyondesign.com

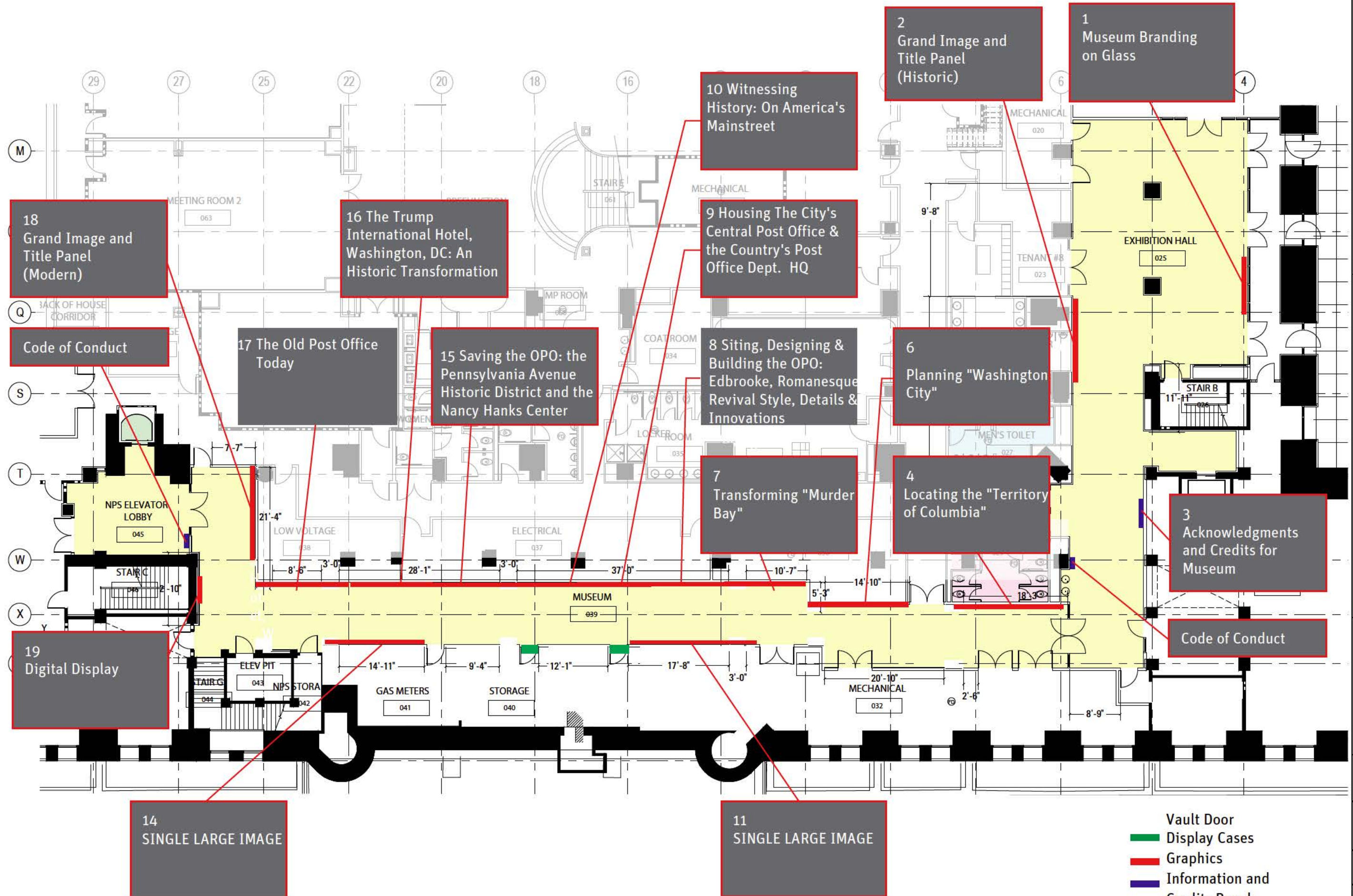

NOT FOR CONSTRUCTION

Revisions

Trump Old Post Of ice
110 Pennsylvania Ave, NW
Washington, DC 200 4

Old Post Of ice Museum
& Clock Tower

Thematic Plan

10/21/15

GS1-2.1

© 2014 Catt Lyon Design + Wayfinding. All Rights Reserved.

18 Grand Image and Title Panel (Modern)

16 The Trump International Hotel, Washington, DC: An Historic Transformation

10 Witnessing History: On America's Mainstreet

2 Grand Image and Title Panel (Historic)

1 Museum Branding on Glass

Code of Conduct

17 The Old Post Office Today

15 Saving the OPO: the Pennsylvania Avenue Historic District and the Nancy Hanks Center

9 Housing The City's Central Post Office & the Country's Post Office Dept. HQ

8 Siting, Designing & Building the OPO: Edbrooke, Romanesque Revival Style, Details & Innovations

6 Planning "Washington City"

19 Digital Display

7 Transforming "Murder Bay"

4 Locating the "Territory of Columbia"

3 Acknowledgments and Credits for Museum

14 SINGLE LARGE IMAGE

11 SINGLE LARGE IMAGE

Code of Conduct

- Vault Door
- Display Cases
- Graphics
- Information and Credits Panels

1 TOPO Ground Floor
Scale: 1/16"=1'-0"

Themes for Old Post Office Museum(1).pdf

From: [David Orowitz](#)
To: [Keller, Jamie](#); [Nixon, Robin](#); [Laura Cohen](#)
Cc: [Brett Banks \(brett.banks@gsa.gov\)](#); [clyon@cattlyondesign.com](#); [Simon Lyon](#)
Subject: Themes for Old Post Office Museum
Date: Friday, October 30, 2015 12:36:00 PM
Attachments: [2015_10_26 TOPO Museum Layout.pdf](#)

Robin, Jamie, and Laura,

Hope all is well. As it has been a while, I wanted to give you a quick update on the status for the Trump portion of the museum. We have been on hold for a while as the rest of the building got further developed, but please find attached the basic “themes” that we plan to include in the museum. Once these get developed, we will share again prior to finalizing, but wanted to keep you in the loop on status.

If there is anyone else from NPS that should have been on here, I apologize and please forward on to them. If you have any questions or comments, please feel free to give me a call.

Best,
Dave

David Orowitz
Senior Vice President, Acquisitions and Development
The Trump Organization
725 Fifth Avenue | New York, NY | 10022
p. 212.836.3252 | m. 646.315.4698 | f. 212.836.3202
dorowitz@trumporg.com | trump.com

This e-mail message, and any attachments to it, are for the sole use of the intended recipients, and may contain confidential and privileged information. Any unauthorized review, use, disclosure or distribution of this email message or its attachments is prohibited. If you are not the intended recipient, please contact the sender by reply email and destroy all copies of the original message. Please note that any views or opinions presented in this email are solely those of the author and do not necessarily represent those of the company. Finally, while the company uses virus protection, the recipient should check this email and any attachments for the presence of viruses. The company accepts no liability for any damage caused by any virus transmitted by this email.

2015_10_26 TOPO Museum Layout_1.pdf



CATT LYON
DESIGN + WAYFINDING

53 W Jackson Blvd, #362
Chicago, IL 60604
Voice 312 435 2855

1375 Broadway Fl. 3
New York, NY 10018
Voice 212 226 2626

212 Ludow Avenue
Cincinnati, OH 45220
Voice 513 221 3500

www.cattlyondesign.com

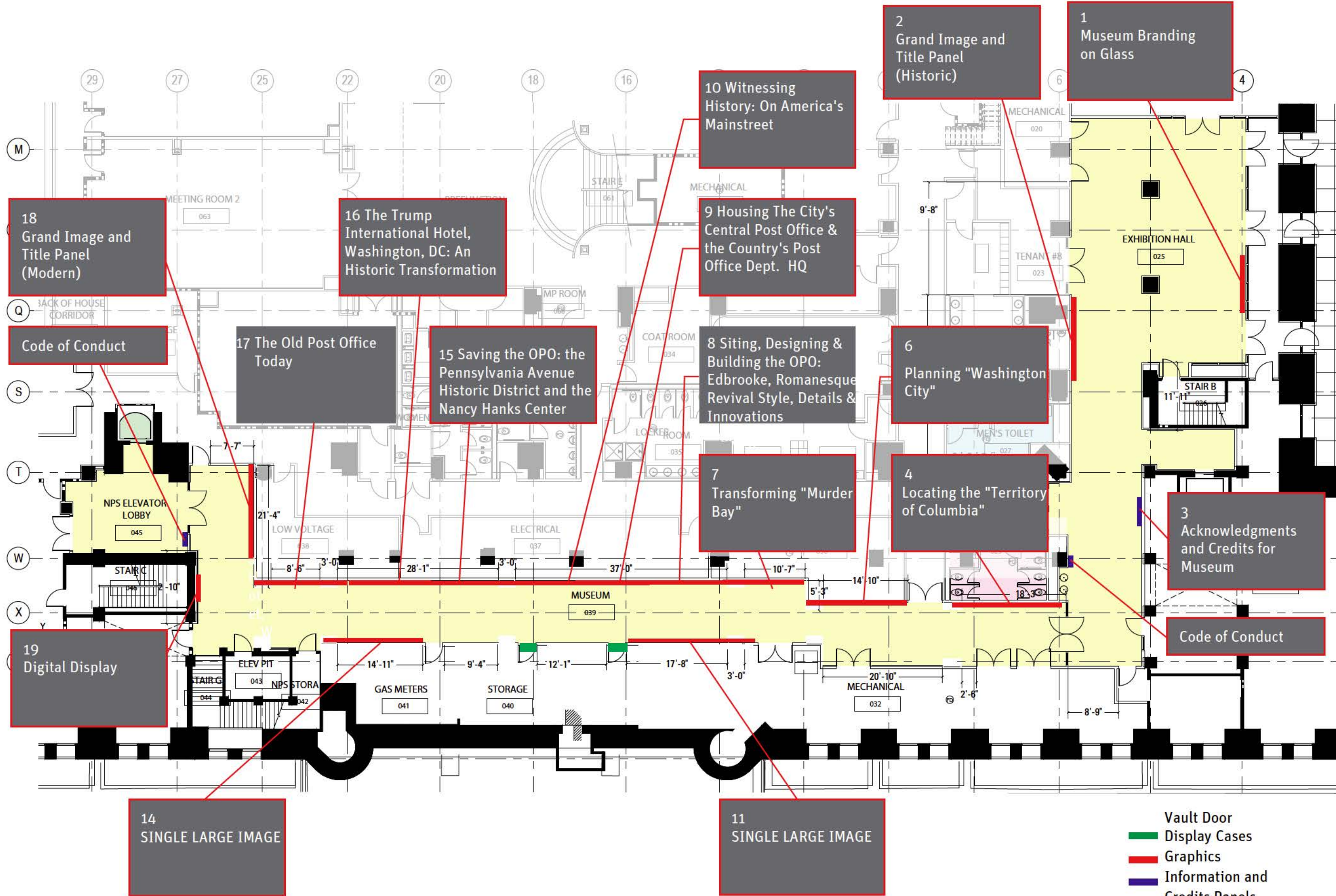

NOT FOR CONSTRUCTION

Revisions

Trump Old Post Of ice
110 Pennsylvania Ave, NW
Washington, DC 200 4

Old Post Of ice Museum
& Clock Tower

Thematic Plan

10/21/15

GS1-2.1

© 2014 Catt Lyon Design + Wayfinding. All Rights Reserved.

1 TOPO Ground Floor
Scale: 1/16" = 1'-0"

- █ Vault Door
- █ Display Cases
- █ Graphics
- █ Information and Credits Panels

Re_ Themes for Old Post Office Museum.pdf

From: [Ollig, Paul](#)
To: dorowitz@trumporg.com
Cc: [Keller, Jamie](#); [Nixon, Robin](#); [Laura Cohen](#); [Brett Banks - WPT-C](#); clyon@cattlyondesign.com; slyon@cattlyondesign.com; [Susan Spain](#)
Subject: Re: Themes for Old Post Office Museum
Date: Thursday, November 05, 2015 2:33:35 PM

Hi David,

We reviewed the plan for the entrance hallway at the Old Post Office that leads into the NPS area and just had a few clarifying questions for you:

1. What is the "title" referenced in #2 and #18 going to say, precisely?
2. What do you envision going on the digital display (#19), and who would provide that content?
3. What do you envision the large images in #11 and #14 to be?
4. It looks like #'s 5, 12, and 13 are missing. Are they located elsewhere?
5. Are the restroom located below the label for #4 public restrooms? If so, what do you anticipate the capacity of those being?
6. Out of curiosity, what's the plan to address accessibility in these exhibits? Is it possible to see a design template? We would love to be able to craft our exhibits in a way that is complimentary (while still maintaining the NPS graphic identity).
7. Is it possible to add some orientation signage that says, "this way to the tower"?
8. It would also be great to include a posting of the hours of operation for the tower. Is there a place where that could go?

Thanks! Looking forward to seeing these develop more.

Cheers,
Paul

Paul Ollig
Chief, Interpretation and Education
National Mall and Memorial Parks
office: (202)245-4682
cell: (202)603-8974

On Fri, Oct 30, 2015 at 2:41 PM, Cohen, Laura <laura_cohen@nps.gov> wrote:

fyi

[Laura Cohen](#)

Digital Content Strategist

National Park Service

Office of Communications

202-740-8273

[Twitter](#) | [Facebook](#) | [YouTube](#) | [Instagram](#) | [Web](#)



Centennial Goal: Connect with and create the next generation of park visitors, supporters, and advocates.

----- Forwarded message -----

From: **David Orowitz** <dorowitz@trumporg.com>

Date: Fri, Oct 30, 2015 at 2:37 PM

Subject: Themes for Old Post Office Museum

To: "Keller, Jamie" <jamie_keller@nps.gov>, "Nixon, Robin" <robin_nixon@nps.gov>, Laura Cohen <laura_cohen@nps.gov>

Cc: "Brett Banks (brett.banks@gsa.gov)" <brett.banks@gsa.gov>, "clyon@cattlyondesign.com" <clyon@cattlyondesign.com>, Simon Lyon <slyon@cattlyondesign.com>

Robin, Jamie, and Laura,

Hope all is well. As it has been a while, I wanted to give you a quick update on the status for the Trump portion of the museum. We have been on hold for a while as the rest of the building got further developed, but please find attached the basic "themes" that we plan to include in the museum. Once these get developed, we will share again prior to finalizing, but wanted to keep you in the loop on status.

If there is anyone else from NPS that should have been on here, I apologize and please forward on to them. If you have any questions or comments, please feel free to give me a call.

Best,

Dave

David Orowitz
Senior Vice President, Acquisitions and Development

The Trump Organization

725 Fifth Avenue | New York, NY | 10022
p. 212.836.3252 | m. 646.315.4698 | f. 212.836.3202

dorowitz@trumporg.com | trump.com

This e-mail message, and any attachments to it, are for the sole use of the intended recipients, and may contain confidential and privileged information. Any unauthorized review, use, disclosure or distribution of this email message or its attachments is prohibited. If you are not the intended recipient, please contact the sender by reply email and destroy all copies of the original message. Please note that any views or opinions presented in this email are solely those of the author and do not necessarily represent those of the company. Finally, while the company uses virus protection, the recipient should check this email and any attachments for the presence of viruses. The company accepts no liability for any damage caused by any virus transmitted by this email.

RE_ Themes for Old Post Office Museum_1.pdf

From: [David Orowitz](#)
To: [Ollig, Paul](#)
Cc: [Keller, Jamie](#); [Nixon, Robin](#); [Laura Cohen](#); [Brett Banks - WPT-C](#); clyon@cattlyondesign.com; slyon@cattlyondesign.com; [Susan Spain](#)
Subject: RE: Themes for Old Post Office Museum
Date: Monday, November 09, 2015 9:05:19 AM

Paul,

Thanks for getting back to us with your comments quickly. We are reviewing and will respond once we have answers compiled.

Best,
Dave

David Orowitz

Senior Vice President, Acquisitions and Development
The Trump Organization
725 Fifth Avenue | New York, NY | 10022
p. 212.836.3252 | m. 646.315.4698 | f. 212.836.3202
dorowitz@trumporg.com | trump.com

From: Ollig, Paul [mailto:paul_ollig@nps.gov]
Sent: Thursday, November 05, 2015 4:33 PM
To: David Orowitz
Cc: Keller, Jamie; Nixon, Robin; Laura Cohen; Brett Banks - WPT-C; clyon@cattlyondesign.com; slyon@cattlyondesign.com; Susan Spain
Subject: Re: Themes for Old Post Office Museum

Hi David,

We reviewed the plan for the entrance hallway at the Old Post Office that leads into the NPS area and just had a few clarifying questions for you:

1. What is the "title" referenced in #2 and #18 going to say, precisely?
2. What do you envision going on the digital display (#19), and who would provide that content?
3. What do you envision the large images in #11 and #14 to be?
4. It looks like #'s 5, 12, and 13 are missing. Are they located elsewhere?
5. Are the restroom located below the label for #4 public restrooms? If so, what do you anticipate the capacity of those being?
6. Out of curiosity, what's the plan to address accessibility in these exhibits? Is it possible to see a design template? We would love to be able to craft our exhibits in a way that is complimentary (while still maintaining the NPS graphic identity).
7. Is it possible to add some orientation signage that says, "this way to the tower"?
8. It would also be great to include a posting of the hours of operation for the tower. Is there a place where that could go?

Thanks! Looking forward to seeing these develop more.

Cheers,
Paul

Paul Ollig

Chief, Interpretation and Education
National Mall and Memorial Parks
office:
(202)245-4682
cell: (202)603-8974

On Fri, Oct 30, 2015 at 2:41 PM, Cohen, Laura <laura_cohen@nps.gov> wrote:

fyi

[Laura Cohen](#)

Digital Content Strategist
National Park Service
Office of Communications
202-740-8273

[Twitter](#) | [Facebook](#) | [YouTube](#) | [Instagram](#) | [Web](#)



**Centennial Goal: Connect with and
create the next generation of park
visitors, supporters, and advocates.**

----- Forwarded message -----

From: **David Orowitz** <dorowitz@trumporg.com>

Date: Fri, Oct 30, 2015 at 2:37 PM

Subject: Themes for Old Post Office Museum

To: "Keller, Jamie" <jamie_keller@nps.gov>, "Nixon, Robin" <robin_nixon@nps.gov>, Laura Cohen <laura_cohen@nps.gov>

Cc: "Brett Banks (brett.banks@gsa.gov)" <brett.banks@gsa.gov>, "clyon@cattlyondesign.com" <clyon@cattlyondesign.com>, Simon Lyon <slyon@cattlyondesign.com>

Robin, Jamie, and Laura,

Hope all is well. As it has been a while, I wanted to give you a quick update on the status for the Trump portion of the museum. We have been on hold for a while as the rest of the building got further developed, but please find attached the basic "themes" that we plan to include in the museum. Once these get developed, we will share again prior to finalizing, but wanted to keep you in the loop on status.

If there is anyone else from NPS that should have been on here, I apologize and please forward on to them. If you have any questions or comments, please feel free to give me a call.

Best,

Dave

David Orowitz

Senior Vice President, Acquisitions and Development

The Trump Organization

725 Fifth Avenue | New York, NY | 10022

p. 212.836.3252 | m. 646.315.4698 | f. 212.836.3202

dorowitz@trumporg.com | trump.com

This e-mail message, and any attachments to it, are for the sole use of the intended recipients, and may contain confidential and privileged information. Any unauthorized review, use, disclosure or distribution of this email message or its attachments is prohibited. If you are not the intended recipient, please contact the sender by reply email and destroy all copies of the original message. Please note that any views or opinions presented in this email are solely those of the author and do not necessarily represent those of the company. Finally, while the company uses virus protection, the recipient should check this email and any attachments for the presence of viruses. The company accepts no liability for any damage caused by any virus transmitted by this email.

RE_ Themes for Old Post Office Museum(1).pdf

From: [David Orowitz](#)
To: [Ollig, Paul](#)
Cc: [Keller, Jamie](#); [Nixon, Robin](#); [Laura Cohen](#); [Brett Banks - WPT-C](#); clyon@cattlyondesign.com; slyon@cattlyondesign.com; [Susan Spain](#)
Subject: RE: Themes for Old Post Office Museum
Date: Monday, November 09, 2015 9:05:20 AM

Paul,

Thanks for getting back to us with your comments quickly. We are reviewing and will respond once we have answers compiled.

Best,
Dave

David Orowitz

Senior Vice President, Acquisitions and Development
The Trump Organization
725 Fifth Avenue | New York, NY | 10022
p. 212.836.3252 | m. 646.315.4698 | f. 212.836.3202
dorowitz@trumporg.com | trump.com

From: Ollig, Paul [mailto:paul_ollig@nps.gov]
Sent: Thursday, November 05, 2015 4:33 PM
To: David Orowitz
Cc: Keller, Jamie; Nixon, Robin; Laura Cohen; Brett Banks - WPT-C; clyon@cattlyondesign.com; slyon@cattlyondesign.com; Susan Spain
Subject: Re: Themes for Old Post Office Museum

Hi David,

We reviewed the plan for the entrance hallway at the Old Post Office that leads into the NPS area and just had a few clarifying questions for you:

1. What is the "title" referenced in #2 and #18 going to say, precisely?
2. What do you envision going on the digital display (#19), and who would provide that content?
3. What do you envision the large images in #11 and #14 to be?
4. It looks like #'s 5, 12, and 13 are missing. Are they located elsewhere?
5. Are the restroom located below the label for #4 public restrooms? If so, what do you anticipate the capacity of those being?
6. Out of curiosity, what's the plan to address accessibility in these exhibits? Is it possible to see a design template? We would love to be able to craft our exhibits in a way that is complimentary (while still maintaining the NPS graphic identity).
7. Is it possible to add some orientation signage that says, "this way to the tower"?
8. It would also be great to include a posting of the hours of operation for the tower. Is there a place where that could go?

Thanks! Looking forward to seeing these develop more.

Cheers,
Paul

Paul Ollig

Chief, Interpretation and Education
National Mall and Memorial Parks
office:
(202)245-4682
cell: (202)603-8974

On Fri, Oct 30, 2015 at 2:41 PM, Cohen, Laura <laura_cohen@nps.gov> wrote:

fyi

[Laura Cohen](#)

Digital Content Strategist
National Park Service
Office of Communications
202-740-8273

[Twitter](#) | [Facebook](#) | [YouTube](#) | [Instagram](#) | [Web](#)



**Centennial Goal: Connect with and
create the next generation of park
visitors, supporters, and advocates.**

----- Forwarded message -----

From: **David Orowitz** <dorowitz@trumporg.com>

Date: Fri, Oct 30, 2015 at 2:37 PM

Subject: Themes for Old Post Office Museum

To: "Keller, Jamie" <jamie_keller@nps.gov>, "Nixon, Robin" <robin_nixon@nps.gov>, Laura Cohen <laura_cohen@nps.gov>

Cc: "Brett Banks (brett.banks@gsa.gov)" <brett.banks@gsa.gov>, "clyon@cattlyondesign.com" <clyon@cattlyondesign.com>, Simon Lyon <slyon@cattlyondesign.com>

Robin, Jamie, and Laura,

Hope all is well. As it has been a while, I wanted to give you a quick update on the status for the Trump portion of the museum. We have been on hold for a while as the rest of the building got further developed, but please find attached the basic "themes" that we plan to include in the museum. Once these get developed, we will share again prior to finalizing, but wanted to keep you in the loop on status.

If there is anyone else from NPS that should have been on here, I apologize and please forward on to them. If you have any questions or comments, please feel free to give me a call.

Best,

Dave

David Orowitz

Senior Vice President, Acquisitions and Development

The Trump Organization

725 Fifth Avenue | New York, NY | 10022

p. 212.836.3252 | m. 646.315.4698 | f. 212.836.3202

dorowitz@trumporg.com | trump.com

This e-mail message, and any attachments to it, are for the sole use of the intended recipients, and may contain confidential and privileged information. Any unauthorized review, use, disclosure or distribution of this email message or its attachments is prohibited. If you are not the intended recipient, please contact the sender by reply email and destroy all copies of the original message. Please note that any views or opinions presented in this email are solely those of the author and do not necessarily represent those of the company. Finally, while the company uses virus protection, the recipient should check this email and any attachments for the presence of viruses. The company accepts no liability for any damage caused by any virus transmitted by this email.

RE_ Themes for Old Post Office Museum(3).pdf

From: [David Orowitz](#)
To: [Ollig, Paul](#)
Cc: [Keller, Jamie](#); [Nixon, Robin](#); [Laura Cohen](#); [Brett Banks - WPT-C](#); clyon@cattlyondesign.com; slyon@cattlyondesign.com; [Susan Spain](#)
Subject: RE: Themes for Old Post Office Museum
Date: Friday, November 13, 2015 1:26:16 PM
Attachments: [151111 TOPO Museum Specifications.png](#)

Paul,

Thanks again for the comments / questions. Please find below responses in blue caps. Have a great weekend.

1. What is the "title" referenced in #2 and #18 going to say, precisely? TBD
2. What do you envision going on the digital display (#19), and who would provide that content? WE HAVE A VIDEOGRAPHER VIDEOTAPING PORTIONS OF THE REDEVELOPMENT. WE ARE NOT SURE EXACTLY WHAT WILL BE RECORDED / INCLUDED, BUT LIKELY THAT WILL MAKE UP THE MAJORITY OF THE CONTENT.
3. What do you envision the large images in #11 and #14 to be? TBD
4. It looks like #'s 5, 12, and 13 are missing. Are they located elsewhere? NO. THESE NUMBERS ARE NO LONGER RELEVANT (WE HAVE CONSOLIDATED SOME PANELS).
5. Are the restroom located below the label for #4 public restrooms? YES If so, what do you anticipate the capacity of those being? THESE WILL ONLY BE USED BY GUESTS TO THE MUSEUMS AND LIMITED RETAIL. THEY ARE MEN (2 TOILETS, 3 URINALS) WOMEN (5 TOILETS).
6. Out of curiosity, what's the plan to address accessibility in these exhibits? CLD IS PLANNING TO INCLUDE BRAILLE INTERPRETIVE PLAQUES AT KEY LOCATIONS.
7. Is it possible to see a design template? We would love to be able to craft our exhibits in a way that is complimentary (while still maintaining the NPS graphic identity). PLEASE SEE ATTACHED.
8. Is it possible to add some orientation signage that says, "this way to the tower"? WE CAN CONSIDER DOING THIS ON THE INTERIOR (THE EXTERIOR IS MORE SENSITIVE TO THE APPROVAL AGENCIES AND LIKELY WOULD REQUIRE NPS TO APPLY FOR SOMETHING THAT WE COULD AGREE TO SUPPORT). WHERE WERE YOU THINKING THIS WOULD BE?
9. It would also be great to include a posting of the hours of operation for the tower. Is there a place where that could go? WE CAN FIND A PLACE FOR THIS. WE ASSUME IT SHOULD GO IN THE EXHIBITION GALLERY NEAR THE ENTRANCE OF THE TRUMP HOTEL (POTENTIALLY WITH THE CODE OF CONDUCT). WHERE WOULD YOU LIKE THIS TO GO? OUR INTENTION IS TO OPERATE THE TRUMP MUSEUM THE SAME HOURS AS THE NPS'S SPACE. CAN YOU LET US KNOW THE HOURS THAT YOU EXPECT TO OPERATE AS WELL?

Best,
Dave

David Orowitz
Senior Vice President, Acquisitions and Development

The Trump Organization
725 Fifth Avenue | New York, NY | 10022
p. 212.836.3252 | m. 646.315.4698 | f. 212.836.3202
dorowitz@trumporg.com | trump.com

From: Ollig, Paul [mailto:paul_ollig@nps.gov]
Sent: Thursday, November 05, 2015 4:33 PM
To: David Orowitz
Cc: Keller, Jamie; Nixon, Robin; Laura Cohen; Brett Banks - WPT-C; clyon@cattlyondesign.com; slyon@cattlyondesign.com; Susan Spain
Subject: Re: Themes for Old Post Office Museum

Hi David,

We reviewed the plan for the entrance hallway at the Old Post Office that leads into the NPS area and just had a few clarifying questions for you:

1. What is the "title" referenced in #2 and #18 going to say, precisely?
2. What do you envision going on the digital display (#19), and who would provide that content?
3. What do you envision the large images in #11 and #14 to be?
4. It looks like #'s 5, 12, and 13 are missing. Are they located elsewhere?
5. Are the restroom located below the label for #4 public restrooms? If so, what do you anticipate the capacity of those being?
6. Out of curiosity, what's the plan to address accessibility in these exhibits? Is it possible to see a design template? We would love to be able to craft our exhibits in a way that is complimentary (while still maintaining the NPS graphic identity).
7. Is it possible to add some orientation signage that says, "this way to the tower"?
8. It would also be great to include a posting of the hours of operation for the tower. Is there a place where that could go?

Thanks! Looking forward to seeing these develop more.

Cheers,
Paul

Paul Ollig
Chief, Interpretation and Education
National Mall and Memorial Parks
office:
(202)245-4682
cell: (202)603-8974

On Fri, Oct 30, 2015 at 2:41 PM, Cohen, Laura <laura_cohen@nps.gov> wrote:
fyi

[Laura Cohen](#)
Digital Content Strategist
National Park Service
Office of Communications
202-740-8273

[Twitter](#) | [Facebook](#) | [YouTube](#) | [Instagram](#) | [Web](#)



Centennial Goal: Connect with and create the next generation of park visitors, supporters, and advocates.

----- Forwarded message -----

From: **David Orowitz** <dorowitz@trumporg.com>

Date: Fri, Oct 30, 2015 at 2:37 PM

Subject: Themes for Old Post Office Museum

To: "Keller, Jamie" <jamie_keller@nps.gov>, "Nixon, Robin" <robin_nixon@nps.gov>, Laura Cohen <laura_cohen@nps.gov>

Cc: "Brett Banks (brett.banks@gsa.gov)" <brett.banks@gsa.gov>, "clyon@cattlyondesign.com" <clyon@cattlyondesign.com>, Simon Lyon <slyon@cattlyondesign.com>

Robin, Jamie, and Laura,

Hope all is well. As it has been a while, I wanted to give you a quick update on the status for the Trump portion of the museum. We have been on hold for a while as the rest of the building got further developed, but please find attached the basic "themes" that we plan to include in the museum. Once these get developed, we will share again prior to finalizing, but wanted to keep you in the loop on status.

If there is anyone else from NPS that should have been on here, I apologize and please forward on to them. If you have any questions or comments, please feel free to give me a call.

Best,
Dave

David Orowitz

Senior Vice President, Acquisitions and Development
The Trump Organization
725 Fifth Avenue | New York, NY | 10022
p. 212.836.3252 | m. 646.315.4698 | f. 212.836.3202
dorowitz@trumporg.com | trump.com

This e-mail message, and any attachments to it, are for the sole use of the intended recipients, and may contain confidential and privileged information. Any unauthorized review, use, disclosure or distribution of this email message or its attachments is prohibited. If you are not the intended recipient, please contact the sender by reply email and destroy all copies of the original message. Please note that any views or opinions presented in this email are solely those of the author and do not necessarily represent those of the company. Finally, while the

company uses virus protection, the recipient should check this email and any attachments for the presence of viruses. The company accepts no liability for any damage caused by any virus transmitted by this email.

151111 TOPO Museum Specifications.pdf

Old Post Office Museum
Typical Layout
9.2.15

The space will be finished to #5 finish drywall.
 Interior finishes provided will include painted walls (dark blue), finished white tile floor, white painted ceiling with exhibition lighting system.

The exhibit space is approximately 450 lineal feet.

1. Captions and interpretive text to be silkscreened directly to wall.
2. Large format color prints, sizes varying from (4'x5' to 8'x10'), sealed with graffiti proof satin finish over-laminate. Mounting substrate is 1/4" thick acrylic with subframe for 1" stand-off, Z-clipped to wall.
3. Framed photographs, sizes varying from (1'x1' to 4'x4'). All framed photos are matted with white acid-free board, glass is anti-reflective, frame is anodized dark bronze aluminum, hung with vandal-proof hardware.
4. Section headings are water-jet cut brass lettering, brushed horiz. finish, sealed with clear acrylic polyurethane, stud mounted to wall.
5. Tactile and Braille plaques, at 4'-2" AFF, will provide a Braille translation of interpretive copy and nearby captions for imagery.

cattlyondesign.com

53 W. Jackson Blvd. #362
 Chicago, IL 60604
 Voice 312.435.2855



CATT LYON
 DESIGN + WAYFINDING

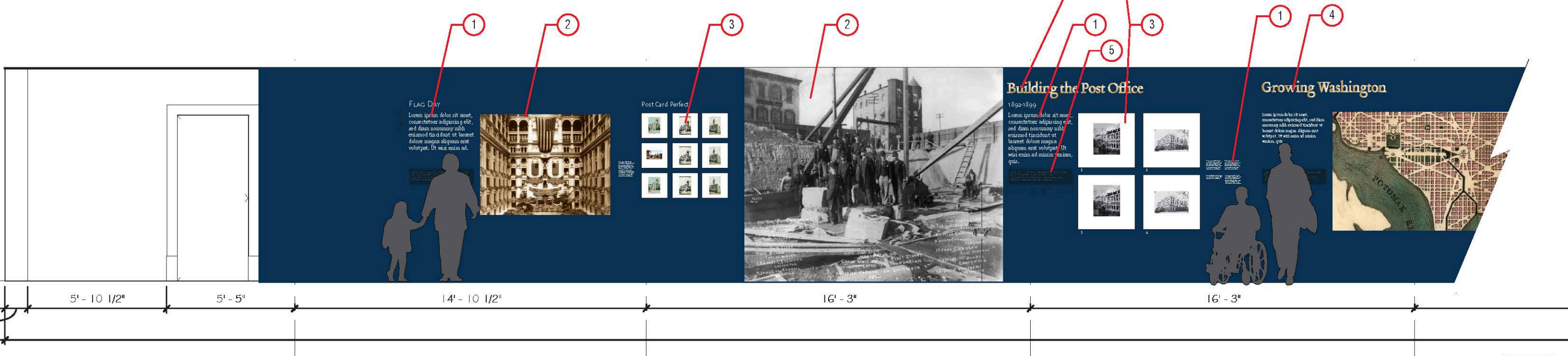
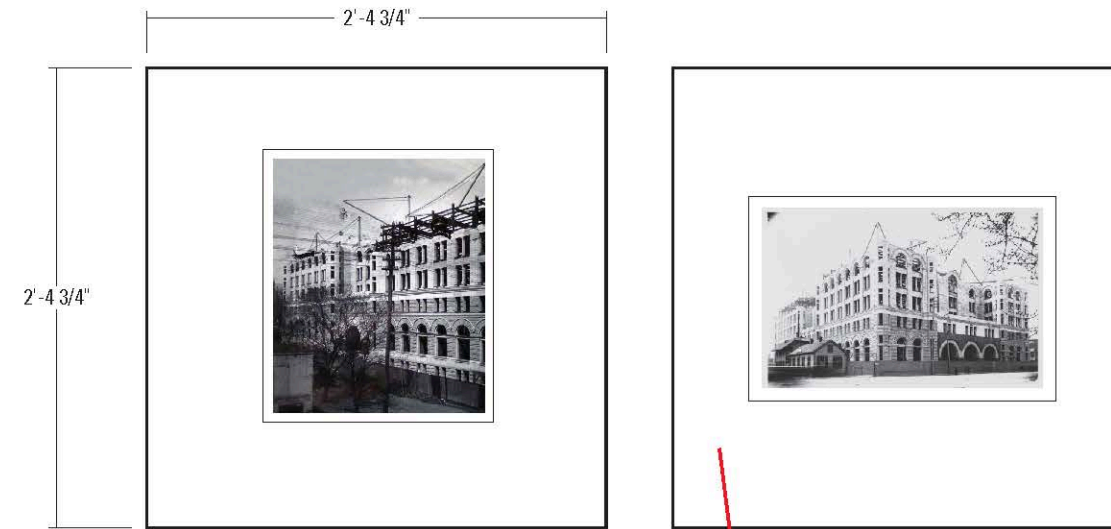

Museum Elevation
 Scale: 1/4" = 1'-0"

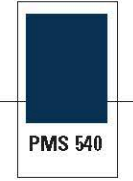

RE_ Themes for Old Post Office Museum(2).pdf

From: [David Orowitz](#)
To: [Ollig, Paul](#)
Cc: [Keller, Jamie](#); [Nixon, Robin](#); [Laura Cohen](#); [Brett Banks - WPT-C](#); clyon@cattlyondesign.com; slyon@cattlyondesign.com; [Susan Spain](#)
Subject: RE: Themes for Old Post Office Museum
Date: Friday, November 13, 2015 1:26:16 PM
Attachments: [151111 TOPO Museum Specifications.png](#)

Paul,

Thanks again for the comments / questions. Please find below responses in blue caps. Have a great weekend.

1. What is the "title" referenced in #2 and #18 going to say, precisely? TBD
2. What do you envision going on the digital display (#19), and who would provide that content? WE HAVE A VIDEOGRAPHER VIDEOTAPING PORTIONS OF THE REDEVELOPMENT. WE ARE NOT SURE EXACTLY WHAT WILL BE RECORDED / INCLUDED, BUT LIKELY THAT WILL MAKE UP THE MAJORITY OF THE CONTENT.
3. What do you envision the large images in #11 and #14 to be? TBD
4. It looks like #'s 5, 12, and 13 are missing. Are they located elsewhere? NO. THESE NUMBERS ARE NO LONGER RELEVANT (WE HAVE CONSOLIDATED SOME PANELS).
5. Are the restroom located below the label for #4 public restrooms? YES If so, what do you anticipate the capacity of those being? THESE WILL ONLY BE USED BY GUESTS TO THE MUSEUMS AND LIMITED RETAIL. THEY ARE MEN (2 TOILETS, 3 URINALS) WOMEN (5 TOILETS).
6. Out of curiosity, what's the plan to address accessibility in these exhibits? CLD IS PLANNING TO INCLUDE BRAILLE INTERPRETIVE PLAQUES AT KEY LOCATIONS.
7. Is it possible to see a design template? We would love to be able to craft our exhibits in a way that is complimentary (while still maintaining the NPS graphic identity). PLEASE SEE ATTACHED.
8. Is it possible to add some orientation signage that says, "this way to the tower"? WE CAN CONSIDER DOING THIS ON THE INTERIOR (THE EXTERIOR IS MORE SENSITIVE TO THE APPROVAL AGENCIES AND LIKELY WOULD REQUIRE NPS TO APPLY FOR SOMETHING THAT WE COULD AGREE TO SUPPORT). WHERE WERE YOU THINKING THIS WOULD BE?
9. It would also be great to include a posting of the hours of operation for the tower. Is there a place where that could go? WE CAN FIND A PLACE FOR THIS. WE ASSUME IT SHOULD GO IN THE EXHIBITION GALLERY NEAR THE ENTRANCE OF THE TRUMP HOTEL (POTENTIALLY WITH THE CODE OF CONDUCT). WHERE WOULD YOU LIKE THIS TO GO? OUR INTENTION IS TO OPERATE THE TRUMP MUSEUM THE SAME HOURS AS THE NPS'S SPACE. CAN YOU LET US KNOW THE HOURS THAT YOU EXPECT TO OPERATE AS WELL?

Best,
Dave

David Orowitz
Senior Vice President, Acquisitions and Development

The Trump Organization
725 Fifth Avenue | New York, NY | 10022
p. 212.836.3252 | m. 646.315.4698 | f. 212.836.3202
dorowitz@trumporg.com | trump.com

From: Ollig, Paul [mailto:paul_ollig@nps.gov]
Sent: Thursday, November 05, 2015 4:33 PM
To: David Orowitz
Cc: Keller, Jamie; Nixon, Robin; Laura Cohen; Brett Banks - WPT-C; clyon@cattlyondesign.com; slyon@cattlyondesign.com; Susan Spain
Subject: Re: Themes for Old Post Office Museum

Hi David,

We reviewed the plan for the entrance hallway at the Old Post Office that leads into the NPS area and just had a few clarifying questions for you:

1. What is the "title" referenced in #2 and #18 going to say, precisely?
2. What do you envision going on the digital display (#19), and who would provide that content?
3. What do you envision the large images in #11 and #14 to be?
4. It looks like #'s 5, 12, and 13 are missing. Are they located elsewhere?
5. Are the restroom located below the label for #4 public restrooms? If so, what do you anticipate the capacity of those being?
6. Out of curiosity, what's the plan to address accessibility in these exhibits? Is it possible to see a design template? We would love to be able to craft our exhibits in a way that is complimentary (while still maintaining the NPS graphic identity).
7. Is it possible to add some orientation signage that says, "this way to the tower"?
8. It would also be great to include a posting of the hours of operation for the tower. Is there a place where that could go?

Thanks! Looking forward to seeing these develop more.

Cheers,
Paul

Paul Ollig
Chief, Interpretation and Education
National Mall and Memorial Parks
office:
(202)245-4682
cell: (202)603-8974

On Fri, Oct 30, 2015 at 2:41 PM, Cohen, Laura <laura_cohen@nps.gov> wrote:
fyi

[Laura Cohen](#)
Digital Content Strategist
National Park Service
Office of Communications
202-740-8273

[Twitter](#) | [Facebook](#) | [YouTube](#) | [Instagram](#) | [Web](#)



**Centennial Goal: Connect with and
create the next generation of park
visitors, supporters, and advocates.**

----- Forwarded message -----

From: **David Orowitz** <dorowitz@trumporg.com>

Date: Fri, Oct 30, 2015 at 2:37 PM

Subject: Themes for Old Post Office Museum

To: "Keller, Jamie" <jamie_keller@nps.gov>, "Nixon, Robin" <robin_nixon@nps.gov>, Laura Cohen <laura_cohen@nps.gov>

Cc: "Brett Banks (brett.banks@gsa.gov)" <brett.banks@gsa.gov>, "clyon@cattlyondesign.com" <clyon@cattlyondesign.com>, Simon Lyon <slyon@cattlyondesign.com>

Robin, Jamie, and Laura,

Hope all is well. As it has been a while, I wanted to give you a quick update on the status for the Trump portion of the museum. We have been on hold for a while as the rest of the building got further developed, but please find attached the basic "themes" that we plan to include in the museum. Once these get developed, we will share again prior to finalizing, but wanted to keep you in the loop on status.

If there is anyone else from NPS that should have been on here, I apologize and please forward on to them. If you have any questions or comments, please feel free to give me a call.

Best,
Dave

David Orowitz

Senior Vice President, Acquisitions and Development
The Trump Organization
725 Fifth Avenue | New York, NY | 10022
p. 212.836.3252 | m. 646.315.4698 | f. 212.836.3202
dorowitz@trumporg.com | trump.com

This e-mail message, and any attachments to it, are for the sole use of the intended recipients, and may contain confidential and privileged information. Any unauthorized review, use, disclosure or distribution of this email message or its attachments is prohibited. If you are not the intended recipient, please contact the sender by reply email and destroy all copies of the original message. Please note that any views or opinions presented in this email are solely those of the author and do not necessarily represent those of the company. Finally, while the

company uses virus protection, the recipient should check this email and any attachments for the presence of viruses. The company accepts no liability for any damage caused by any virus transmitted by this email.

151111 TOPO Museum Specifications_1.pdf

Old Post Office Museum
Typical Layout
9.2.15

The space will be finished to #5 finish drywall.
 Interior finishes provided will include painted walls (dark blue), finished white tile floor, white painted ceiling with exhibition lighting system.

The exhibit space is approximately 450 lineal feet.

1. Captions and interpretive text to be silkscreened directly to wall.
2. Large format color prints, sizes varying from (4'x5' to 8'x10'), sealed with graffiti proof satin finish over-laminate. Mounting substrate is 1/4" thick acrylic with subframe for 1" stand-off, Z-clipped to wall.
3. Framed photographs, sizes varying from (1'x1' to 4'x4'). All framed photos are matted with white acid-free board, glass is anti-reflective, frame is anodized dark bronze aluminum, hung with vandal-proof hardware.
4. Section headings are water-jet cut brass lettering, brushed horiz. finish, sealed with clear acrylic polyurethane, stud mounted to wall.
5. Tactile and Braille plaques, at 4'-2" AFF, will provide a Braille translation of interpretive copy and nearby captions for imagery.

cattlyondesign.com

53 W. Jackson Blvd. #362
 Chicago, IL 60604
 Voice 312.435.2855



CATT LYON
 DESIGN + WAYFINDING

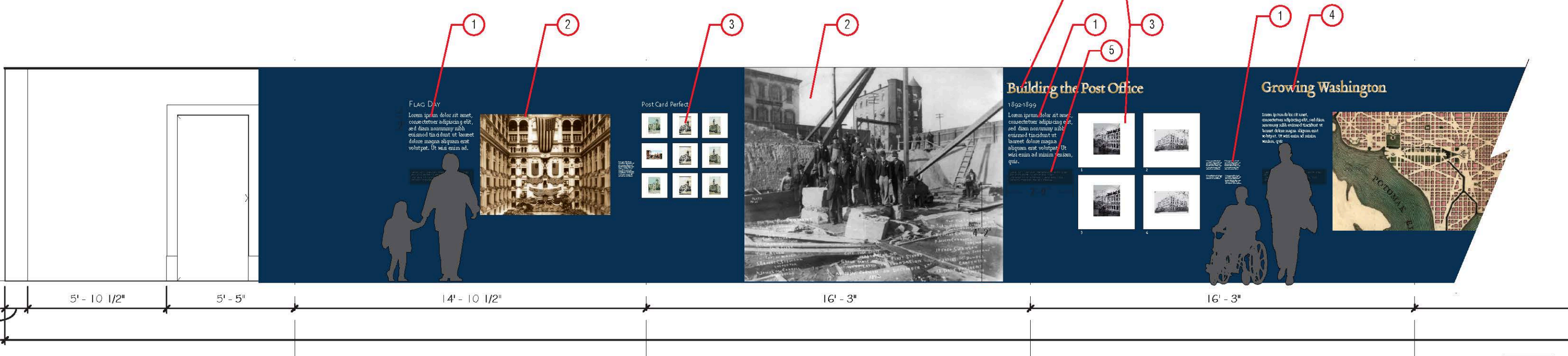
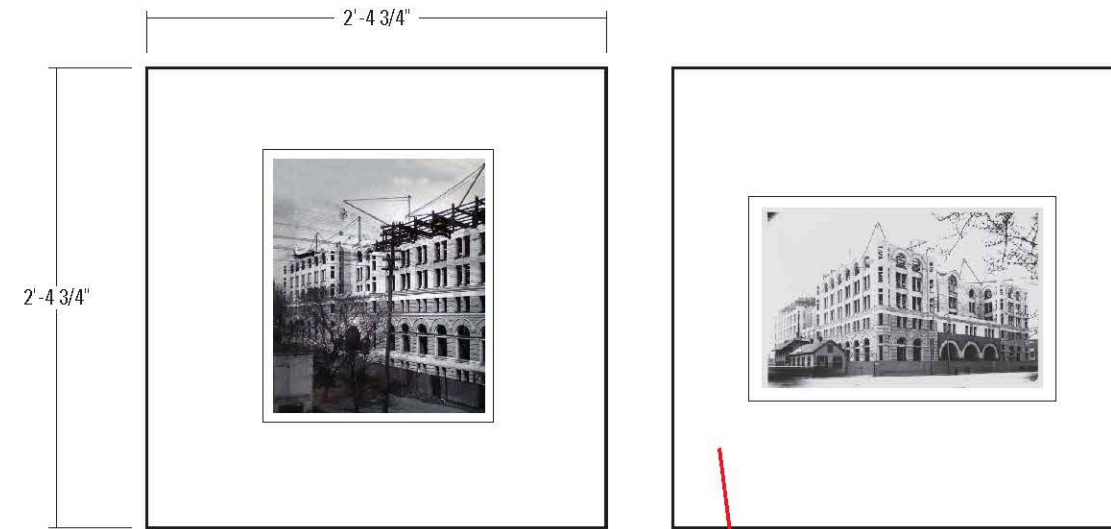

Museum Elevation
 Scale: 1/4" = 1'-0"

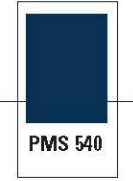

Re_ Themes for Old Post Office Museum(1)_1.pdf

From: [Ollig, Paul](#)
To: [David Orowitz](#)
Cc: [Keller, Jamie](#); [Nixon, Robin](#); [Laura Cohen](#); [Brett Banks - WPT-C](#); clyon@cattlyondesign.com; slyon@cattlyondesign.com; [Susan Spain](#)
Subject: Re: Themes for Old Post Office Museum
Date: Monday, November 16, 2015 6:54:39 AM

Hi David,

Thanks for the response and for the design overview. I'm actually pretty excited about the look that seems to be emerging in it, as it closely matches the colors and feel of the new exhibits at the Washington Monument. We'll take a look at the other responses you gave us and get the answers to your questions to you shortly.

Thanks, again!
Paul

Paul Ollig
Chief, Interpretation and Education
National Mall and Memorial Parks
office: (202)245-4682
cell: (202)603-8974

On Fri, Nov 13, 2015 at 3:26 PM, David Orowitz <dorowitz@trumporg.com> wrote:

Paul,

Thanks again for the comments / questions. Please find below responses in blue caps. Have a great weekend.

1. What is the "title" referenced in #2 and #18 going to say, precisely? TBD
2. What do you envision going on the digital display (#19), and who would provide that content? WE HAVE A VIDEOGRAPHER VIDEOTAPING PORTIONS OF THE REDEVELOPMENT. WE ARE NOT SURE EXACTLY WHAT WILL BE RECORDED / INCLUDED, BUT LIKELY THAT WILL MAKE UP THE MAJORITY OF THE CONTENT.
3. What do you envision the large images in #11 and #14 to be? TBD
4. It looks like #'s 5, 12, and 13 are missing. Are they located elsewhere? NO. THESE NUMBERS ARE NO LONGER RELEVANT (WE HAVE CONSOLIDATED SOME PANELS).
5. Are the restroom located below the label for #4 public restrooms? YES If so, what do you anticipate the capacity of those being? THESE WILL ONLY BE USED BY GUESTS TO THE MUSEUMS AND LIMITED RETAIL. THEY ARE MEN (2 TOILETS, 3 URINALS) WOMEN (5 TOILETS).
6. Out of curiosity, what's the plan to address accessibility in these exhibits? CLD IS PLANNING TO INCLUDE BRAILLE INTERPRETIVE PLAQUES AT KEY LOCATIONS.
7. Is it possible to see a design template? We would love to be able to craft our exhibits in a way that is complimentary (while still maintaining the NPS

graphic identity). PLEASE SEE ATTACHED.

8. Is it possible to add some orientation signage that says, "this way to the tower"? WE CAN CONSIDER DOING THIS ON THE INTERIOR (THE EXTERIOR IS MORE SENSITIVE TO THE APPROVAL AGENCIES AND LIKELY WOULD REQUIRE NPS TO APPLY FOR SOMETHING THAT WE COULD AGREE TO SUPPORT). WHERE WERE YOU THINKING THIS WOULD BE?
9. It would also be great to include a posting of the hours of operation for the tower. Is there a place where that could go? WE CAN FIND A PLACE FOR THIS. WE ASSUME IT SHOULD GO IN THE EXHIBITION GALLERY NEAR THE ENTRANCE OF THE TRUMP HOTEL (POTENTIALLY WITH THE CODE OF CONDUCT). WHERE WOULD YOU LIKE THIS TO GO? OUR INTENTION IS TO OPERATE THE TRUMP MUSEUM THE SAME HOURS AS THE NPS'S SPACE. CAN YOU LET US KNOW THE HOURS THAT YOU EXPECT TO OPERATE AS WELL?

Best,

Dave

David Orowitz

Senior Vice President, Acquisitions and Development

The Trump Organization

725 Fifth Avenue | New York, NY | 10022
p. 212.836.3252 | m. 646.315.4698 | f. 212.836.3202

dorowitz@trumporg.com | trump.com

From: Ollig, Paul [mailto:paul_ollig@nps.gov]

Sent: Thursday, November 05, 2015 4:33 PM

To: David Orowitz

Cc: Keller, Jamie; Nixon, Robin; Laura Cohen; Brett Banks - WPT-C; clyon@cattlyondesign.com; slyon@cattlyondesign.com; Susan Spain

Subject: Re: Themes for Old Post Office Museum

Hi David,

We reviewed the plan for the entrance hallway at the Old Post Office that leads into the NPS area and just had a few clarifying questions for you:

1. What is the "title" referenced in #2 and #18 going to say, precisely?
2. What do you envision going on the digital display (#19), and who would provide that content?
3. What do you envision the large images in #11 and #14 to be?
4. It looks like #'s 5, 12, and 13 are missing. Are they located elsewhere?
5. Are the restroom located below the label for #4 public restrooms? If so, what do you anticipate the capacity of those being?

6. Out of curiosity, what's the plan to address accessibility in these exhibits? Is it possible to see a design template? We would love to be able to craft our exhibits in a way that is complimentary (while still maintaining the NPS graphic identity).
7. Is it possible to add some orientation signage that says, "this way to the tower"?
8. It would also be great to include a posting of the hours of operation for the tower. Is there a place where that could go?

Thanks! Looking forward to seeing these develop more.

Cheers,

Paul

Paul Ollig

Chief, Interpretation and Education

National Mall and Memorial Parks

office:

(202)245-4682

cell: (202)603-8974

On Fri, Oct 30, 2015 at 2:41 PM, Cohen, Laura <laura_cohen@nps.gov> wrote:

fyi

[Laura Cohen](#)

Digital Content Strategist

National Park Service
Office of Communications

202-740-8273

[Twitter](#) | [Facebook](#) | [YouTube](#) | [Instagram](#) | [Web](#)



Centennial Goal: Connect with and create the next generation of park visitors, supporters, and advocates.

----- Forwarded message -----

From: **David Orowitz** <dorowitz@trumporg.com>
Date: Fri, Oct 30, 2015 at 2:37 PM
Subject: Themes for Old Post Office Museum
To: "Keller, Jamie" <jamie_keller@nps.gov>, "Nixon, Robin" <robin_nixon@nps.gov>, Laura Cohen <laura_cohen@nps.gov>
Cc: "Brett Banks (brett.banks@gsa.gov)" <brett.banks@gsa.gov>, "clyon@cattlyondesign.com" <clyon@cattlyondesign.com>, Simon Lyon <slyon@cattlyondesign.com>

Robin, Jamie, and Laura,

Hope all is well. As it has been a while, I wanted to give you a quick update on the status for the Trump portion of the museum. We have been on hold for a while as the rest of the building got further developed, but please find attached the basic "themes" that we plan to include in the museum. Once these get developed, we will share again prior to finalizing, but wanted to keep you in the loop on status.

If there is anyone else from NPS that should have been on here, I apologize and please forward on to them. If you have any questions or comments, please feel free to give me a call.

Best,

Dave

David Orowitz

Senior Vice President, Acquisitions and Development

The Trump Organization

725 Fifth Avenue | New York, NY | 10022

p. 212.836.3252 | m. 646.315.4698 | f. 212.836.3202

dorowitz@trumporg.com | trump.com

This e-mail message, and any attachments to it, are for the sole use of the intended recipients, and may contain confidential and privileged information. Any unauthorized review, use, disclosure or distribution of this email message or its attachments is prohibited. If you are not the intended recipient, please contact the sender by reply email and destroy all copies of the original message. Please note that any views or opinions presented in this email are solely those of the author and do not necessarily represent those of the company. Finally, while the company uses virus protection, the recipient should check this email and any attachments for the presence of viruses. The company accepts no liability for any damage caused by any virus transmitted by this email.

Out of Office_ Themes for Old Post Office Museum.pdf

From: [David Orowitz](#)
To: [Ollig, Paul](#)
Subject: Out of Office: Themes for Old Post Office Museum
Date: Monday, November 16, 2015 6:55:05 AM

I am travelling internationally on business until November 23rd. During this time, I will have intermittent access to email, but will try to respond as quickly as possible. Have a great day.

This e-mail message, and any attachments to it, are for the sole use of the intended recipients, and may contain confidential and privileged information. Any unauthorized review, use, disclosure or distribution of this email message or its attachments is prohibited. If you are not the intended recipient, please contact the sender by reply email and destroy all copies of the original message. Please note that any views or opinions presented in this email are solely those of the author and do not necessarily represent those of the company. Finally, while the company uses virus protection, the recipient should check this email and any attachments for the presence of viruses. The company accepts no liability for any damage caused by any virus transmitted by this email.

RE_ Themes for Old Post Office Museum(4).pdf

From: [David Orowitz](#)
To: [Ollig, Paul](#)
Cc: [Keller, Jamie](#); [Nixon, Robin](#); [Laura Cohen](#); [Brett Banks - WPT-C](#); clyon@cattlyondesign.com; slyon@cattlyondesign.com; [Susan Spain](#)
Subject: RE: Themes for Old Post Office Museum
Date: Monday, November 16, 2015 10:41:09 AM

Thanks, Paul. We think it looks great as well. Excited to get into the content.

Best,
Dave

David Orowitz
Senior Vice President, Acquisitions and Development
The Trump Organization
725 Fifth Avenue | New York, NY | 10022
p. 212.836.3252 | m. 646.315.4698 | f. 212.836.3202
dorowitz@trumporg.com | trump.com

From: Ollig, Paul [mailto:paul_ollig@nps.gov]
Sent: Monday, November 16, 2015 8:55 AM
To: David Orowitz
Cc: Keller, Jamie; Nixon, Robin; Laura Cohen; Brett Banks - WPT-C; clyon@cattlyondesign.com; slyon@cattlyondesign.com; Susan Spain
Subject: Re: Themes for Old Post Office Museum

Hi David,
Thanks for the response and for the design overview. I'm actually pretty excited about the look that seems to be emerging in it, as it closely matches the colors and feel of the new exhibits at the Washington Monument. We'll take a look at the other responses you gave us and get the answers to your questions to you shortly.

Thanks, again!
Paul

Paul Ollig
Chief, Interpretation and Education
National Mall and Memorial Parks
office:
(202)245-4682
cell: (202)603-8974

On Fri, Nov 13, 2015 at 3:26 PM, David Orowitz <dorowitz@trumporg.com> wrote:
Paul,

Thanks again for the comments / questions. Please find below responses in blue caps. Have a great weekend.

1. What is the "title" referenced in #2 and #18 going to say, precisely? TBD
2. What do you envision going on the digital display (#19), and who would provide that content? WE HAVE A VIDEOGRAPHER VIDEOTAPING PORTIONS OF THE REDEVELOPMENT. WE ARE NOT SURE EXACTLY WHAT WILL BE

RECORDED / INCLUDED, BUT LIKELY THAT WILL MAKE UP THE MAJORITY OF THE CONTENT.

3. What do you envision the large images in #11 and #14 to be? TBD
4. It looks like #'s 5, 12, and 13 are missing. Are they located elsewhere? NO. THESE NUMBERS ARE NO LONGER RELEVANT (WE HAVE CONSOLIDATED SOME PANELS).
5. Are the restroom located below the label for #4 public restrooms? YES If so, what do you anticipate the capacity of those being? THESE WILL ONLY BE USED BY GUESTS TO THE MUSEUMS AND LIMITED RETAIL. THEY ARE MEN (2 TOILETS, 3 URINALS) WOMEN (5 TOILETS).
6. Out of curiosity, what's the plan to address accessibility in these exhibits? CLD IS PLANNING TO INCLUDE BRAILLE INTERPRETIVE PLAQUES AT KEY LOCATIONS.
7. Is it possible to see a design template? We would love to be able to craft our exhibits in a way that is complimentary (while still maintaining the NPS graphic identity). PLEASE SEE ATTACHED.
8. Is it possible to add some orientation signage that says, "this way to the tower"? WE CAN CONSIDER DOING THIS ON THE INTERIOR (THE EXTERIOR IS MORE SENSITIVE TO THE APPROVAL AGENCIES AND LIKELY WOULD REQUIRE NPS TO APPLY FOR SOMETHING THAT WE COULD AGREE TO SUPPORT). WHERE WERE YOU THINKING THIS WOULD BE?
9. It would also be great to include a posting of the hours of operation for the tower. Is there a place where that could go? WE CAN FIND A PLACE FOR THIS. WE ASSUME IT SHOULD GO IN THE EXHIBITION GALLERY NEAR THE ENTRANCE OF THE TRUMP HOTEL (POTENTIALLY WITH THE CODE OF CONDUCT). WHERE WOULD YOU LIKE THIS TO GO? OUR INTENTION IS TO OPERATE THE TRUMP MUSEUM THE SAME HOURS AS THE NPS'S SPACE. CAN YOU LET US KNOW THE HOURS THAT YOU EXPECT TO OPERATE AS WELL?

Best,
Dave

David Orowitz

Senior Vice President, Acquisitions and Development
The Trump Organization
725 Fifth Avenue | New York, NY | 10022
p. 212.836.3252 | m. 646.315.4698 | f. 212.836.3202
dorowitz@trumporg.com | trump.com

From: Ollig, Paul [mailto:paul_ollig@nps.gov]

Sent: Thursday, November 05, 2015 4:33 PM

To: David Orowitz

Cc: Keller, Jamie; Nixon, Robin; Laura Cohen; Brett Banks - WPT-C; clyon@cattlyondesign.com; slyon@cattlyondesign.com; Susan Spain

Subject: Re: Themes for Old Post Office Museum

Hi David,

We reviewed the plan for the entrance hallway at the Old Post Office that leads into the NPS area and just had a few clarifying questions for you:

1. What is the "title" referenced in #2 and #18 going to say, precisely?
2. What do you envision going on the digital display (#19), and who would provide that content?
3. What do you envision the large images in #11 and #14 to be?

4. It looks like #'s 5, 12, and 13 are missing. Are they located elsewhere?
5. Are the restroom located below the label for #4 public restrooms? If so, what do you anticipate the capacity of those being?
6. Out of curiosity, what's the plan to address accessibility in these exhibits? Is it possible to see a design template? We would love to be able to craft our exhibits in a way that is complimentary (while still maintaining the NPS graphic identity).
7. Is it possible to add some orientation signage that says, "this way to the tower"?
8. It would also be great to include a posting of the hours of operation for the tower. Is there a place where that could go?

Thanks! Looking forward to seeing these develop more.

Cheers,
Paul

Paul Ollig
Chief, Interpretation and Education
National Mall and Memorial Parks
office:
(202)245-4682
cell: (202)603-8974

On Fri, Oct 30, 2015 at 2:41 PM, Cohen, Laura <laura_cohen@nps.gov> wrote:
fyi

[Laura Cohen](#)
Digital Content Strategist
National Park Service
Office of Communications
202-740-8273

[Twitter](#) | [Facebook](#) | [YouTube](#) | [Instagram](#) | [Web](#)



**Centennial Goal: Connect with and
create the next generation of park
visitors, supporters, and advocates.**

----- Forwarded message -----
From: **David Orowitz** <dorowitz@trumporg.com>
Date: Fri, Oct 30, 2015 at 2:37 PM
Subject: Themes for Old Post Office Museum

To: "Keller, Jamie" <jamie_keller@nps.gov>, "Nixon, Robin" <robin_nixon@nps.gov>, Laura Cohen <laura_cohen@nps.gov>
Cc: "Brett Banks (brett.banks@gsa.gov)" <brett.banks@gsa.gov>, "clyon@cattlyondesign.com" <clyon@cattlyondesign.com>, Simon Lyon <slyon@cattlyondesign.com>

Robin, Jamie, and Laura,

Hope all is well. As it has been a while, I wanted to give you a quick update on the status for the Trump portion of the museum. We have been on hold for a while as the rest of the building got further developed, but please find attached the basic “themes” that we plan to include in the museum. Once these get developed, we will share again prior to finalizing, but wanted to keep you in the loop on status.

If there is anyone else from NPS that should have been on here, I apologize and please forward on to them. If you have any questions or comments, please feel free to give me a call.

Best,
Dave

David Orowitz

Senior Vice President, Acquisitions and Development
The Trump Organization
725 Fifth Avenue | New York, NY | 10022
p. 212.836.3252 | m. 646.315.4698 | f. 212.836.3202
dorowitz@trumporg.com | trump.com

This e-mail message, and any attachments to it, are for the sole use of the intended recipients, and may contain confidential and privileged information. Any unauthorized review, use, disclosure or distribution of this email message or its attachments is prohibited. If you are not the intended recipient, please contact the sender by reply email and destroy all copies of the original message. Please note that any views or opinions presented in this email are solely those of the author and do not necessarily represent those of the company. Finally, while the company uses virus protection, the recipient should check this email and any attachments for the presence of viruses. The company accepts no liability for any damage caused by any virus transmitted by this email.

RE_ Themes for Old Post Office Museum(5).pdf

From: [David Orowitz](#)
To: [Ollig, Paul](#)
Cc: [Keller, Jamie](#); [Nixon, Robin](#); [Laura Cohen](#); [Brett Banks - WPT-C](#); clyon@cattlyondesign.com; slyon@cattlyondesign.com; [Susan Spain](#)
Subject: RE: Themes for Old Post Office Museum
Date: Monday, November 16, 2015 10:41:27 AM

Thanks, Paul. We think it looks great as well. Excited to get into the content.

Best,
Dave

David Orowitz
Senior Vice President, Acquisitions and Development
The Trump Organization
725 Fifth Avenue | New York, NY | 10022
p. 212.836.3252 | m. 646.315.4698 | f. 212.836.3202
dorowitz@trumporg.com | trump.com

From: Ollig, Paul [mailto:paul_ollig@nps.gov]
Sent: Monday, November 16, 2015 8:55 AM
To: David Orowitz
Cc: Keller, Jamie; Nixon, Robin; Laura Cohen; Brett Banks - WPT-C; clyon@cattlyondesign.com; slyon@cattlyondesign.com; Susan Spain
Subject: Re: Themes for Old Post Office Museum

Hi David,
Thanks for the response and for the design overview. I'm actually pretty excited about the look that seems to be emerging in it, as it closely matches the colors and feel of the new exhibits at the Washington Monument. We'll take a look at the other responses you gave us and get the answers to your questions to you shortly.

Thanks, again!
Paul

Paul Ollig
Chief, Interpretation and Education
National Mall and Memorial Parks
office:
(202)245-4682
cell: (202)603-8974

On Fri, Nov 13, 2015 at 3:26 PM, David Orowitz <dorowitz@trumporg.com> wrote:
Paul,

Thanks again for the comments / questions. Please find below responses in blue caps. Have a great weekend.

1. What is the "title" referenced in #2 and #18 going to say, precisely? TBD
2. What do you envision going on the digital display (#19), and who would provide that content? WE HAVE A VIDEOGRAPHER VIDEOTAPING PORTIONS OF THE REDEVELOPMENT. WE ARE NOT SURE EXACTLY WHAT WILL BE

RECORDED / INCLUDED, BUT LIKELY THAT WILL MAKE UP THE MAJORITY OF THE CONTENT.

3. What do you envision the large images in #11 and #14 to be? TBD
4. It looks like #'s 5, 12, and 13 are missing. Are they located elsewhere? NO. THESE NUMBERS ARE NO LONGER RELEVANT (WE HAVE CONSOLIDATED SOME PANELS).
5. Are the restroom located below the label for #4 public restrooms? YES If so, what do you anticipate the capacity of those being? THESE WILL ONLY BE USED BY GUESTS TO THE MUSEUMS AND LIMITED RETAIL. THEY ARE MEN (2 TOILETS, 3 URINALS) WOMEN (5 TOILETS).
6. Out of curiosity, what's the plan to address accessibility in these exhibits? CLD IS PLANNING TO INCLUDE BRAILLE INTERPRETIVE PLAQUES AT KEY LOCATIONS.
7. Is it possible to see a design template? We would love to be able to craft our exhibits in a way that is complimentary (while still maintaining the NPS graphic identity). PLEASE SEE ATTACHED.
8. Is it possible to add some orientation signage that says, "this way to the tower"? WE CAN CONSIDER DOING THIS ON THE INTERIOR (THE EXTERIOR IS MORE SENSITIVE TO THE APPROVAL AGENCIES AND LIKELY WOULD REQUIRE NPS TO APPLY FOR SOMETHING THAT WE COULD AGREE TO SUPPORT). WHERE WERE YOU THINKING THIS WOULD BE?
9. It would also be great to include a posting of the hours of operation for the tower. Is there a place where that could go? WE CAN FIND A PLACE FOR THIS. WE ASSUME IT SHOULD GO IN THE EXHIBITION GALLERY NEAR THE ENTRANCE OF THE TRUMP HOTEL (POTENTIALLY WITH THE CODE OF CONDUCT). WHERE WOULD YOU LIKE THIS TO GO? OUR INTENTION IS TO OPERATE THE TRUMP MUSEUM THE SAME HOURS AS THE NPS'S SPACE. CAN YOU LET US KNOW THE HOURS THAT YOU EXPECT TO OPERATE AS WELL?

Best,
Dave

David Orowitz

Senior Vice President, Acquisitions and Development
The Trump Organization
725 Fifth Avenue | New York, NY | 10022
p. 212.836.3252 | m. 646.315.4698 | f. 212.836.3202
dorowitz@trumporg.com | trump.com

From: Ollig, Paul [mailto:paul_ollig@nps.gov]

Sent: Thursday, November 05, 2015 4:33 PM

To: David Orowitz

Cc: Keller, Jamie; Nixon, Robin; Laura Cohen; Brett Banks - WPT-C; clyon@cattlyondesign.com; slyon@cattlyondesign.com; Susan Spain

Subject: Re: Themes for Old Post Office Museum

Hi David,

We reviewed the plan for the entrance hallway at the Old Post Office that leads into the NPS area and just had a few clarifying questions for you:

1. What is the "title" referenced in #2 and #18 going to say, precisely?
2. What do you envision going on the digital display (#19), and who would provide that content?
3. What do you envision the large images in #11 and #14 to be?

4. It looks like #'s 5, 12, and 13 are missing. Are they located elsewhere?
5. Are the restroom located below the label for #4 public restrooms? If so, what do you anticipate the capacity of those being?
6. Out of curiosity, what's the plan to address accessibility in these exhibits? Is it possible to see a design template? We would love to be able to craft our exhibits in a way that is complimentary (while still maintaining the NPS graphic identity).
7. Is it possible to add some orientation signage that says, "this way to the tower"?
8. It would also be great to include a posting of the hours of operation for the tower. Is there a place where that could go?

Thanks! Looking forward to seeing these develop more.

Cheers,
Paul

Paul Ollig
Chief, Interpretation and Education
National Mall and Memorial Parks
office:
(202)245-4682
cell: (202)603-8974

On Fri, Oct 30, 2015 at 2:41 PM, Cohen, Laura <laura_cohen@nps.gov> wrote:
fyi

[Laura Cohen](#)
Digital Content Strategist
National Park Service
Office of Communications
202-740-8273

[Twitter](#) | [Facebook](#) | [YouTube](#) | [Instagram](#) | [Web](#)



**Centennial Goal: Connect with and
create the next generation of park
visitors, supporters, and advocates.**

----- Forwarded message -----
From: **David Orowitz** <dorowitz@trumporg.com>
Date: Fri, Oct 30, 2015 at 2:37 PM
Subject: Themes for Old Post Office Museum

To: "Keller, Jamie" <jamie_keller@nps.gov>, "Nixon, Robin" <robin_nixon@nps.gov>, Laura Cohen <laura_cohen@nps.gov>
Cc: "Brett Banks (brett.banks@gsa.gov)" <brett.banks@gsa.gov>, "clyon@cattlyondesign.com" <clyon@cattlyondesign.com>, Simon Lyon <slyon@cattlyondesign.com>

Robin, Jamie, and Laura,

Hope all is well. As it has been a while, I wanted to give you a quick update on the status for the Trump portion of the museum. We have been on hold for a while as the rest of the building got further developed, but please find attached the basic “themes” that we plan to include in the museum. Once these get developed, we will share again prior to finalizing, but wanted to keep you in the loop on status.

If there is anyone else from NPS that should have been on here, I apologize and please forward on to them. If you have any questions or comments, please feel free to give me a call.

Best,
Dave

David Orowitz

Senior Vice President, Acquisitions and Development
The Trump Organization
725 Fifth Avenue | New York, NY | 10022
p. 212.836.3252 | m. 646.315.4698 | f. 212.836.3202
dorowitz@trumporg.com | trump.com

This e-mail message, and any attachments to it, are for the sole use of the intended recipients, and may contain confidential and privileged information. Any unauthorized review, use, disclosure or distribution of this email message or its attachments is prohibited. If you are not the intended recipient, please contact the sender by reply email and destroy all copies of the original message. Please note that any views or opinions presented in this email are solely those of the author and do not necessarily represent those of the company. Finally, while the company uses virus protection, the recipient should check this email and any attachments for the presence of viruses. The company accepts no liability for any damage caused by any virus transmitted by this email.

RE_request for 9th floor 'package'.pdf

From: [Oksana Chernyaeva](#)
To: [Benjamin Yonce](#); [Edmund Newman - WPIA](#)
Cc: [Coratola, Joseph](#)
Subject: RE: request for 9th floor "package"
Date: Wednesday, January 06, 2016 8:21:51 AM

Thanks, Ben!

Oksana Chernyaeva LEED AP, PMP
Senior Project Manager
Trump Old Post Office, LLC
The Old Post Office Building
1100 Pennsylvania Avenue NW
Washington, DC 20004
Mobile: 202.386.4924
E-mail: ochernyaeva@trumporg.com

From: Benjamin Yonce [<mailto:BYonce@wdgarch.com>]
Sent: Wednesday, January 06, 2016 10:18 AM
To: Edmund Newman - WPIA <edmund.newman@gsa.gov>; Oksana Chernyaeva <Ochernyaeva@trumporg.com>
Cc: Coratola, Joseph <joseph_coratola@nps.gov>
Subject: RE: request for 9th floor 'package'

Edmund,

I'll set up a Newforma transfer to Joe, with copies to you and Oksana, momentarily.

Benjamin Yonce | Associate

WDG ARCHITECTURE | 1025 Connecticut Ave., NW, Ste. 300 | Washington, DC 20036 | ph 202.857.8300 x1234 fax 202.463.2198 | www.wdgarch.com |

From: Edmund Newman - WPIA [<mailto:edmund.newman@gsa.gov>]
Sent: Wednesday, January 06, 2016 10:04 AM
To: Oksana Chernyaeva <Ochernyaeva@trumporg.com>
Cc: Coratola, Joseph <joseph_coratola@nps.gov>; Benjamin Yonce <BYonce@wdgarch.com>
Subject: Re: request for 9th floor 'package'

I'm having a bit of trouble getting the package over to NPS, could WDG set up a newforma transfer to them?

Please add Joseph Coratola, his email is on the cc line, and is joseph_coratola@nps.gov.

Joe, you might be able to download the files from the attached link in the string below. Let us know. Thanks.

Also, there will be some adjustments required to the final location of the sink per the revised space plans from Brandi, there was an early rough-in for the sink in a previous

location, there are obstructions in the plumbing pathway below the new location.

Edmund Newman, AIA, Project Manager
Design & Construction Division (NCR)
US General Services Administration
301 7th St. SW Room 4128
Washington, DC 20407
202-401-2881 office
202-308-1940 cell

On Wed, Dec 30, 2015 at 4:31 PM, Oksana Chernyaeva <Ochernyaeva@trumporg.com> wrote:

The original e-mail did not go through due to file size. I attached WDG's e-mail with the link, please let me know if you are able to download directly.

Thanks again,

Oksana

Oksana Chernyaeva LEED AP, PMP
Senior Project Manager
Trump Old Post Office, LLC
The Old Post Office Building
1100 Pennsylvania Avenue NW
Washington, DC 20004
Mobile: 202.386.4924
E-mail: ochernyaeva@trumporg.com

From: Oksana Chernyaeva

Sent: Wednesday, December 30, 2015 4:02 PM

To: 'Edmund Newman - WPIA' <edmund.newman@gsa.gov>

Cc: Brett Banks - WPT-C <brett.banks@gsa.gov>; Stephen Dalton <sdalton@trumporg.com>

Subject: RE: request for 9th floor 'package'

Please see attached plans per your request (Ground floor spaces and 9th floor offices). Also attached is the NPS Finishes file presented to GSA and NPS on 6/12/2014. Please confirm receipt due to file size.

LL confirmed that all plumbing for the NPS Pantry was already roughed in per the CDs. This had to be done in order to close the ceilings in the guestrooms on the 8th floor. They have also indicated that the rough-in for the sink as currently shown in Room 937 is problematic as it is in conflict with the shaft below. It may be possible to shift the pantry to the north wall within the same room, but would require some rework of the ceilings below. They are reviewing in the field, and I hope to have more information soon.

Thank you,

Oksana

Oksana Chernyaeva LEED AP, PMP
Senior Project Manager
Trump Old Post Office, LLC
The Old Post Office Building
1100 Pennsylvania Avenue NW
Washington, DC 200

----- Forwarded message -----

From: "DoNotReply@wdgarch.com" <DoNotReply@wdgarch.com>
To: Oksana Chernyaeva <Ochernyaeva@trumporg.com>
Cc:
Date: Wed, 23 Dec 2015 15:28:22 -0500
Subject: Project: WA11034 - Old Post Off Redev - File Transfer - NPS Spaces

IMPORTANT: Click a link below to access files associated with this transmittal that came in through the WDG Architecture, PLLC Info Exchange web site. The attached file contains the transmittal details.

[Download all associated files](#)

Project Name: WA11034 - Old Post Off Redev
Project Number: WA11034

From: Benjamin Yonce (WDG Architecture, PLLC)
To: Oksana Chernyaeva (The Trump Organization)
CC:
Subject: NPS Spaces
Sent via: Info Exchange
Expiration Date: 1/7/2016

Transferred Files

NAME	TYPE	DATE	TIME	SIZE
2015-12-23_NPS Area.pdf	PDF File	12/23/2015	3:26 PM	28,286 KB

To share and learn more about Newforma Info Exchange visit www.newformant.com

This e-mail message, and any attachments to it, are for the sole use of the intended recipients, and may contain confidential and privileged information. Any unauthorized review, use, disclosure or distribution of this email message or its attachments is prohibited. If you are not the intended recipient, please contact the sender by reply email and destroy all copies of the original message. Please note that any views or opinions presented in this email are solely those of the author and do

not necessarily represent those of the company. Finally, while the company uses virus protection, the recipient should check this email and any attachments for the presence of viruses. The company accepts no liability for any damage caused by any virus transmitted by this email.

RE_request for 9th floor 'package'(1).pdf

From: [Joseph Coratola](#)
To: [Oksana Chernyaeva](#); [Benjamin Yonce](#); [Edmund Newman - WPIA](#)
Subject: RE: request for 9th floor "package"
Date: Wednesday, January 06, 2016 12:36:42 PM

Thanks everyone. I'm downloading them now.

Joe

Joseph Coratola Jr. AIA | Historic Architect

Division of Professional Services
National Mall and Memorial Parks
202-245-4480 (office)
202-779-1854 (cell)



**Centennial Goal: Connect with and
create the next generation of park
visitors, supporters, and advocates.**

From: Oksana Chernyaeva [mailto:Ochernyaeva@trumporg.com]
Sent: Wednesday, January 06, 2016 10:22 AM
To: Benjamin Yonce; Edmund Newman - WPIA
Cc: Coratola, Joseph
Subject: RE: request for 9th floor 'package'

Thanks, Ben!

Oksana Chernyaeva LEED AP, PMP
Senior Project Manager
Trump Old Post Office, LLC
The Old Post Office Building
1100 Pennsylvania Avenue NW
Washington, DC 20004
Mobile: 202.386.4924
E-mail: ochernyaeva@trumporg.com

From: Benjamin Yonce [mailto:BYonce@wdgarch.com]
Sent: Wednesday, January 06, 2016 10:18 AM
To: Edmund Newman - WPIA <edmund.newman@gsa.gov>; Oksana Chernyaeva <Ochernyaeva@trumporg.com>
Cc: Coratola, Joseph <joseph_coratola@nps.gov>
Subject: RE: request for 9th floor 'package'

Edmund,

I'll set up a Newforma transfer to Joe, with copies to you and Oksana, momentarily.

Benjamin Yonce | Associate

WDG ARCHITECTURE | 1025 Connecticut Ave., NW, Ste. 300 | Washington, DC 20036 | ph 202.857.8300 x1234 fax 202.463.2198 | www.wdgarch.com |

From: Edmund Newman - WPIA [<mailto:edmund.newman@gsa.gov>]
Sent: Wednesday, January 06, 2016 10:04 AM
To: Oksana Chernyaeva <Ochernyaeva@trumporg.com>
Cc: Coratola, Joseph <joseph_coratola@nps.gov>; Benjamin Yonce <BYonce@wdgarch.com>
Subject: Re: request for 9th floor 'package'

I'm having a bit of trouble getting the package over to NPS, could WDG set up a newforma transfer to them?

Please add Joseph Coratola, his email is on the cc line, and is joseph_coratola@nps.gov.

Joe, you might be able to download the files from the attached link in the string below. Let us know. Thanks.

Also, there will be some adjustments required to the final location of the sink per the revised space plans from Brandi, there was an early rough-in for the sink in a previous location, there are obstructions in the plumbing pathway below the new location.

Edmund Newman, AIA, Project Manager
Design & Construction Division (NCR)
US General Services Administration
301 7th St. SW Room 4128
Washington, DC 20407
202-401-2881 office
202-308-1940 cell

On Wed, Dec 30, 2015 at 4:31 PM, Oksana Chernyaeva <Ochernyaeva@trumporg.com> wrote:

The original e-mail did not go through due to file size. I attached WDG's e-mail with the link, please let me know if you are able to download directly.

Thanks again,

Oksana

Oksana Chernyaeva LEED AP, PMP
Senior Project Manager
Trump Old Post Office, LLC
The Old Post Office Building
1100 Pennsylvania Avenue NW
Washington, DC 20004
Mobile: 202.386.4924
E-mail: ochernyaeva@trumporg.com

From: Oksana Chernyaeva
Sent: Wednesday, December 30, 2015 4:02 PM
To: 'Edmund Newman - WPIA' <edmund.newman@gsa.gov>
Cc: Brett Banks - WPT-C <brett.banks@gsa.gov>; Stephen Dalton <sdalton@trumporg.com>
Subject: RE: request for 9th floor 'package'

Please see attached plans per your request (Ground floor spaces and 9th floor offices). Also attached is the NPS Finishes file presented to GSA and NPS on 6/12/2014. Please confirm receipt due to file size.

LL confirmed that all plumbing for the NPS Pantry was already roughed in per the CDs. This had to be done in order to close the ceilings in the guestrooms on the 8th floor. They have also indicated that the rough-in for the sink as currently shown in Room 937 is problematic as it is in conflict with the shaft below. It may be possible to shift the pantry to the north wall within the same room, but would require some rework of the ceilings below. They are reviewing in the field, and I hope to have more information soon.

Thank you,

Oksana

Oksana Chernyaeva LEED AP, PMP
Senior Project Manager
Trump Old Post Office, LLC
The Old Post Office Building
1100 Pennsylvania Avenue NW
Washington, DC 200

----- Forwarded message -----

From: "DoNotReply@wdgarch.com" <DoNotReply@wdgarch.com>
To: Oksana Chernyaeva <Ochernyaeva@trumporg.com>
Cc:
Date: Wed, 23 Dec 2015 15:28:22 -0500
Subject: Project: WA11034 - Old Post Off Redev - File Transfer - NPS Spaces

IMPORTANT: Click a link below to access files associated with this transmittal that came in through the WDG Architecture, PLLC Info Exchange web site. The attached file contains the transmittal details.

[Download all associated files](#)

Project Name: WA11034 - Old Post Off Redev
Project Number: WA11034

From: Benjamin Yonce (WDG Architecture, PLLC)
To: Oksana Chernyaeva (The Trump Organization)
CC:
Subject: NPS Spaces

Sent via: Info Exchange

Expiration Date: 1/7/2016

Transferred Files

NAME	TYPE	DATE	TIME	SIZE
2015-12-23_NPS Area.pdf	PDF File	12/23/2015	3:26 PM	28,286 KB

To share and learn more about Newforma Info Exchange visit www.newformant.com

This e-mail message, and any attachments to it, are for the sole use of the intended recipients, and may contain confidential and privileged information. Any unauthorized review, use, disclosure or distribution of this email message or its attachments is prohibited. If you are not the intended recipient, please contact the sender by reply email and destroy all copies of the original message. Please note that any views or opinions presented in this email are solely those of the author and do not necessarily represent those of the company. Finally, while the company uses virus protection, the recipient should check this email and any attachments for the presence of viruses. The company accepts no liability for any damage caused by any virus transmitted by this email.

Re_ Source of this Image_.pdf

From: [Keller, Jamie](#)
To: [Simon Lyon](#)
Cc: [Paul Ollig](#); [Nixon, Robin](#); [Laura Cohen](#); [Susan Spain](#); [David Orowitz](#); [Charleen Lyon](#)
Subject: Re: Source of this Image???
Date: Monday, January 18, 2016 2:59:23 PM

It appears to be from the Washington Post. See the "Make No Little Plans Federal Triangle Heritage Trail" guide at http://www.culturaltourismdc.org/portal/c/document_library/get_file?uuid=25f0e232-fa5e-4424-8bbf-a76a249b22b1&groupId=701982 . Page 10 shows the image with the caption "Members of Don't Tear It Down demonstrate to save the Old Post Office, 1971. The Washington Post"

Regards,

Jamie Keller
Supervisory Park Ranger
National Mall and Memorial Parks
(Cell) 202-505-0674

"Be excellent to each other." -Abraham Lincoln

On Thu, Jan 14, 2016 at 7:02 PM, Simon Lyon <slyon@cattlyondesign.com> wrote:

Hello Paul:

We are the people who are designing the exhibit space in the lower level of the Old Post Office for The Trump Organization.

While visiting the project on Tuesday, we came across this image (attached) on an interpretive kiosk within the fenced-in construction zone and near the entrance to the site.

We thought that the interpretive kiosk might be one of yours.

As it seems to be a better fit for the exhibit than other images we have seen of these protests to save the Building, we were wondering, if you or anyone at NPS may know where it came from, so that we might obtain a scan of it.

(The staff at the DC Preservation League, and former members, have never seen it, before.)

Any insights, as to source, would be very appreciated.

Best regards,

Simon Lyon, VP
Catt Lyon Design Inc.
53 W. Jackson Blvd., #362
Chicago, IL 60604
312/435-2855

Out of Office_ Source of this Image_.pdf

From: [David Orowitz](#)
To: [Keller, Jamie](#)
Subject: Out of Office: Source of this Image???
Date: Monday, January 18, 2016 2:59:30 PM

I am out of the office with limited access to email through January 22nd. If you need immediate assistance, please contact my assistant, Lorena Bonner, at lbonner@trumporg.com. Thank you and have a great day. This e-mail message, and any attachments to it, are for the sole use of the intended recipients, and may contain confidential and privileged information. Any unauthorized review, use, disclosure or distribution of this email message or its attachments is prohibited. If you are not the intended recipient, please contact the sender by reply email and destroy all copies of the original message. Please note that any views or opinions presented in this email are solely those of the author and do not necessarily represent those of the company. Finally, while the company uses virus protection, the recipient should check this email and any attachments for the presence of viruses. The company accepts no liability for any damage caused by any virus transmitted by this email.

Approved



United States Department of the Interior

NATIONAL PARK SERVICE
1849 C Street, N.W.
Washington, DC 20240

IN REPLY REFER TO:

April 21, 2016

Ivanka Trump
Trump Old Post Office, LLC
60 Crossways Park Drive, West, Suite 301
Woodbury, NY 11719

PROPERTY: **Old Post Office, Washington DC**
PROJECT NUMBER: **(30491)**
APPLICATION: **Amendment**
DECISION: **Approved with Conditions and Recommendations**

Dear Ms. Trump:

The National Park Service has reviewed the project amendment for the Historic Preservation Certification Application -- Part 2 for this project and has determined that the project, as modified by the treatments described (**paving at C Street entrance; exterior lighting; removal of marble at 11th and 12 Street entrances; ceiling clouds**) is in conformance with the Secretary of the Interior's Standards provided the attached conditions and recommendations are addressed.

As you are aware, a formal "certification of rehabilitation" can be issued only to the owner or qualified lessee of a "certified historic structure" after the rehabilitation work is completed. At that time, please submit a Request for Certification of Completed Work, with interior and exterior photographs of the completed work, to this office through the State Historic Preservation Office. An onsite inspection of the completed work by an authorized representative of the Secretary of the Interior may be undertaken prior to issuance of the final certification of rehabilitation.

If you have any questions, please call the State Historic Preservation Office or me at (202) 354-2027.

Sincerely,

Audrey T. Teppet
Historical Architect
Technical Preservation Services Branch

cc: DC SHPO
IRS
David Orowitz, The Trump Organization, 725 5th Avenue, New York, NY 10022
Hany Hasan, Beyer, Blinder Belle, 3307 M Street, NW, Ste. 301, Washington, DC 20007

UNITED STATES DEPARTMENT OF THE INTERIOR
NATIONAL PARK SERVICE

CONDITIONS SHEET – *Amendment*

Historic Preservation Certification Application

Property Name: Old Post Office

Project Number: 30491

Property address: 1100 Pennsylvania Avenue, Washington DC

The rehabilitation of this property as described in the Historic Preservation Certification Application will meet the Secretary of the Interior's Standards for Rehabilitation provided that the following condition(s) is/are met:

Removal of Marble at 11th and 12th Street Entrances:

To avoid removing large areas of historic marble to heat and cool the 11th and 12th Street entry vestibules, please investigate the use of concealed ductless HVAC systems. These units could be placed above or to the sides of the non-historic vestibules, which allows more of the building's original (and significant) materials to remain in place at these prominent locations.

Ceiling "Cloud" to Hide Utilities:

The image (and narrative) of the ceiling cloud provided with this submittal suggests that only the trim was revised since we last evaluated this detail. Although what we see appears to be an improvement, this photograph was taken directly beneath the cloud, so it does not illustrate its overall thickness. To lessen the impact of these new features on the historic interior, we had required that the clouds be made thinner. Please forward more comprehensive views of the cloud(s) showing that this condition was met.

Paving at C Street Entrance/Plaza/Driveway:

Although the use of pea-gravel exposed aggregate concrete is an improvement over the previously-proposed poured concrete at the C Street plaza and garage entrance, we continue to believe the use of cobblestone, as per the image sent with the last submittal (dated 2/25/16), is a more historically-appropriate material for this highly visible area. It will also be a more durable material for this heavily-trafficked location, as the exposed aggregate found nearby is used primarily for sidewalks and not for driveways. Therefore, we recommend further investigating patterned cobblestone, or a similar material for this plaza.

Exterior lighting:

We understand that the roofs of many buildings in the area are not lit at night, but we recommend illuminating the roof of the prominent Old Post Office tower as well. It appears possible to sensitively light this feature by hiding lights behind the four turrets surrounding the pyramidal roof; at the prominent cornice at the base of the turrets; and at the slate-covered band at the base of the roof for example. We recommend

4/21/16

NPS-TPS 202.354.2027

Date

National Park Service Authorized Signature

Telephone Number

Audrey T. Tepper